

CURRICULUM AND DETAILED SYLLABI

FOR

B. TECH DEGREE PROGRAMME

IN

ELECTRONICS AND COMMUNICATION ENGINEERING

SEMESTERS I & VIII

**2020 SCHEME
(AUTONOMOUS)**



MAR BASELIOS COLLEGE OF ENGINEERING AND TECHNOLOGY

(Approved by AICTE, Autonomous Institution Affiliated to APJ Abdul Kalam Technological University)
MAR IVANIOS VIDYANAGAR, NALANCHIRA, THIRUVANANTHAPURAM – 695015, KERALA.

Phone: 0471 2545866

Fax: 0471 2545869

Web: www.mbcet.ac.in

email: hodec@mbcet.ac.in



CURRICULUM AND DETAILED SYLLABI

FOR

B. TECH DEGREE PROGRAMME

IN

ELECTRONICS AND COMMUNICATION ENGINEERING

SEMESTERS I & VIII

2020 SCHEME
(AUTONOMOUS)



MAR BASELIOS COLLEGE OF ENGINEERING AND TECHNOLOGY

(Approved by AICTE, Autonomous Institution Affiliated to APJ Abdul Kalam Technological University)
MAR IVANIOS VIDYANAGAR, NALANCHIRA, THIRUVANANTHAPURAM – 695015, KERALA.

Phone: 0471 2545866

Fax: 0471 2545869

Web: www.mbcet.ac.in

email: hodec@mbcet.ac.in



MAR BASELIOS COLLEGE OF ENGINEERING AND TECHNOLOGY

DEPARTMENT OF ELECTRONICS AND COMMUNICATION ENGINEERING

B. TECH DEGREE PROGRAMME

IN

ELECTRONICS AND COMMUNICATION ENGINEERING

CURRICULUM AND DETAILED SYLLABI (S1-S8)

Items	Board of Studies (BoS)	Academic Council (AC)
Date of Approval	18.11.2020	30.12.2020
	04.02.2021	17.02.2021
	25.11.2021	22.04.2022
	11.08.2022	29.08.2022
	24.02.2023	20.03.2023

Head of Department
Chairman, Board of Studies

Principal
Chairman, Academic Council





MAR BASELIOS COLLEGE OF ENGINEERING AND TECHNOLOGY

Vision and Mission of the Institution

Vision:

To be an Institution moulding globally competent professionals as epitomes of Noble Values.

Mission:

To transform the Youth as technically competent, ethically sound and socially committed professionals, by providing a vibrant learning ambience for the welfare of humanity.

DEPARTMENT OF ELECTRONICS AND COMMUNICATION ENGINEERING

Vision and Mission of the Department

Vision:

To be a Centre of Excellence in Electronics and Communication Engineering Education and Research for the service of humanity.

Mission:

To provide quality Engineering Education and to carry out Research in the field of Electronics and Communication Engineering addressing the challenges faced by the society.



PROGRAMME EDUCATIONAL OBJECTIVES (PEOs)

- PEO1:** The graduates of the Programme will have a successful career as Professionals in Industry or as Entrepreneurs, encompassing a broad spectrum of areas related to Electronics and Communication Engineering.
- PEO2:** They will be able to adapt to the changing needs of Industry and Academia through continuous learning and professional upgrading.
- PEO3:** They will exhibit social responsibility in their pursuit of technical excellence.

PROGRAMME OUTCOMES (POs)

Engineering Graduates will have the ability to:

1. **Engineering knowledge:** Apply the knowledge of mathematics, science, engineering fundamentals, and an engineering specialization to the solution of complex engineering problems.
2. **Problem analysis:** Identify, formulate, review research literature, and analyze complex engineering problems reaching substantiated conclusions using first principles of mathematics, natural sciences, and engineering sciences.
3. **Design/development of solutions:** Design solutions for complex engineering problems and design system components or processes that meet the specified needs with appropriate consideration for the public health and safety, and the cultural, societal, and environmental considerations.
4. **Conduct investigations of complex problems:** Use research-based knowledge and research methods including design of experiments, analysis and interpretation of data, and synthesis of the information to provide valid conclusions.
5. **Modern tool usage:** Create, select, and apply appropriate techniques, resources, and modern engineering and IT tools including prediction and modeling to complex engineering activities with an understanding of the limitations.
6. **The engineer and society:** Apply reasoning informed by the contextual knowledge to assess societal, health, safety, legal and cultural issues and the consequent responsibilities relevant to the professional engineering practice.
7. **Environment and sustainability:** Understand the impact of the professional engineering solution in societal and environmental contexts, and demonstrate the knowledge of, and need for sustainable development.
8. **Ethics:** Apply ethical principles and commit to professional ethics and responsibilities and norms of the engineering practice.
9. **Individual and team work:** Function effectively as an individual, and as a member or leader in diverse teams, and in multidisciplinary settings.



10. **Communication:** Communicate effectively on complex engineering activities with the engineering community and with society at large, such as, being able to comprehend and write effective reports and design documentation, make effective presentations, and give and receive clear instructions.
11. **Project management and finance:** Demonstrate knowledge and understanding of the engineering and management principles and apply these to one's own work, as a member and leader in a team, to manage projects and in multidisciplinary environments.
12. **Life-long learning:** Recognize the need for, and have the preparation and ability to engage in independent and life-long learning in the broadest context of technological change.

PROGRAMME SPECIFIC OUTCOMES (PSOs)

PSO1: Design Electronic Circuits and Systems for Communication, Monitoring and Control Applications.

PSO2: Demonstrate the knowledge, in Electronics, Signal processing, Embedded Systems and Communication Engineering, required for providing technical solutions to real world problems



DEPARTMENT OF ELECTRONICS AND COMMUNICATION ENGINEERING

B. Tech Programme in Electronics and Communication Engineering

For the students admitted from 2020-21

Scheduling of Courses

i) Knowledge Segments and Credits

Every course of B. Tech Programme is placed in one of the nine categories as listed in table below. No semester shall have more than six lecture-based courses and two laboratory courses, and/or drawing/seminar/project courses in the curriculum.

Table 1: Credit distribution and the Knowledge Domains

Sl. No.	Category	Category Code	Total credits
1	Humanities and Social Sciences including Management Courses	HSC	8
2	Basic Science Courses	BSC	26
3	Engineering Science Courses	ESC	22
4	Programme Core Courses, Comprehensive Course Work and Viva Voce	PCC	76
5	Programme Elective Courses	PEC	15
6	Open Elective Courses	OEC	3
7	Project Work and Seminar	PWS	10
8	Mandatory Non-credit Courses (P/F) with Grade	MNC	---
9	Mandatory Student Activities (P/F)	MSA	2
	Total Mandatory Credits		162
	Value Added Courses (Optional) – Honours/Minor	VAC	20

ii) Semester-wise Credit Distribution

Semester	I	II	III	IV	V	VI	VII	VIII	Total Credits
Credits for Courses	17	21	22	22	23	23	15	17	160
Activity Points (Min.)	40				60				100
Credits for Activities	2								2
Total Credits									162
Value Added Courses (Optional) – Honours / Minor									20
Total Credits									182



SEMESTER I						
Slot	Cate-gory Code	Course Number	Courses	L-T-P	Hours	Credit
A	BSC	MA0U10A	Linear Algebra and Calculus	3-1-0	4	4
B ½	BSC	PH0U10A	Engineering Physics A	3-1-0	4	4
		CY0U10A	Engineering Chemistry A	3-1-0	4	4
C ½	ESC	ES0U10A	Engineering Mechanics	2-1-0	3	3
		ES0U10B	Engineering Graphics	2-0-2	4	3
D ½	ESC	ES0U10C	Basics of Civil and Mechanical Engineering	4-0-0	4	4
		ES0U10D	Basics of Electrical and Electronics Engineering	4-0-0	4	4
E	HSC	HS0U10A	Life Skills	2-0-2	4	---
S ½	BSC	PH0U18A	Engineering Physics Lab	0-0-2	2	1
		CY0U18A	Engineering Chemistry Lab	0-0-2	2	1
T ½	ESC	ES0U18A	Civil and Mechanical Workshop	0-0-2	2	1
		ES0U18B	Electrical and Electronics Workshop	0-0-2	2	1
TOTAL					23/24	17

SEMESTER II						
Slot	Cate-gory Code	Course Number	Courses	L-T-P	Hours	Credit
A	BSC	MA0U10B	Vector Calculus, Differential Equations and Transforms	3-1-0	4	4
B ½	BSC	PH0U10A	Engineering Physics A	3-1-0	4	4
		CY0U10A	Engineering Chemistry	3-1-0	4	4
C ½	ESC	ES0U10A	Engineering Mechanics	2-1-0	3	3
		ES0U10B	Engineering Graphics	2-0-2	4	3
D ½	ESC	ES0U10C	Basics of Civil and Mechanical Engineering	4-0-0	4	4
		ES0U10D	Basics of Electrical and Electronics Engineering	4-0-0	4	4
E	HSC	HS0U10B	Professional Communication	2-0-2	4	---
F	ESC	ES0U10E	Programming in C	2-1-2	5	4
S ½	BSC	PH0U18A	Engineering Physics Lab	0-0-2	2	1
		CY0U18A	Engineering Chemistry Lab	0-0-2	2	1
T ½	ESC	ES0U18A	Civil and Mechanical Workshop	0-0-2	2	1
		ES0U18B	Electrical and Electronics Workshop	0-0-2	2	1
TOTAL					28/29	21



SEMESTER III						
Slot	Cate-gory Code	Course Number	Courses	L-T-P	Hours	Credit
A	BSC	MA0U20A	Partial Differential Equation and Complex Analysis	3-1-0	4	4
B	PCC	EC1U20A	Solid State Devices	3-1-0	4	4
C	PCC	EC1U20B	Logic Circuit Design	3-1-0	4	4
D	PCC	EC1U20C	Network Theory	3-1-0	4	4
E 1/2	ESC	ES0U20A	Design & Engineering	2-0-0	2	2
	HSC	HS0U20A	Professional Ethics	2-0-0	2	2
F	MNC	NC0U20A	Sustainable Engineering	2-0-0	2	---
S	PCC	EC1U28A	Scientific Computing Lab	0-0-3	3	2
T	PCC	EC1U28B	Logic Design Lab	0-0-3	3	2
R/M	VAC		Remedial/Minor Course	3-1-0/ 4-0-0	4	4
TOTAL					26/30	22/26

SEMESTER IV						
Slot	Cate-gory Code	Course Number	Courses	L-T-P	Hours	Credit
A	BSC	MA0U20C	Probability, Random Processes and Numerical Methods	3-1-0	4	4
B	PCC	EC1U20D	Analog Circuits	3-1-0	4	4
C	PCC	EC1U20E	Signals and Systems	3-1-0	4	4
D	PCC	EC1U20F	Computer Architecture and Microcontrollers	3-1-0	4	4
E ½	ESC	ES0U20A	Design & Engineering	2-0-0	2	2
	HSC	HS0U20A	Professional Ethics	2-0-0	2	2
F	MNC	NC0U20B	Constitution of India	2-0-0	2	---
S	PCC	EC1U28C	Analog Circuits and Simulation Lab	0-0-3	3	2
T	PCC	EC1U28D	Microcontroller Lab	0-0-3	3	2
R/M/H	VAC		Remedial/Minor/Honours Course	3-1-0/ 4-0-0	4	4
TOTAL					26/30	22/26



SEMESTER V						
Slot	Category Code	Course Number	Courses	L-T-P	Hours	Credit
A	PCC	EC1U30A	Linear Integrated Circuits	3-1-0	4	4
B	PCC	EC1U30B	Digital Signal Processing	3-1-0	4	4
C	PCC	EC1U30C	Analog and Digital Communication	3-1-0	4	4
D	PCC	EC1U30D	Control Systems	3-1-0	4	4
E ½	HSC	HS0U30A	Industrial Economics & Foreign Trade	3-0-0	3	3
		HS0U30B	Management for Engineers	3-0-0	3	3
F	MNC	NC0U30A	Disaster Management	2-0-0	2	--
S	PCC	EC1U38A	Analog Integrated Circuits and Simulation Lab	0-0-3	3	2
T	PCC	EC1U38B	Digital Signal Processing Lab	0-0-3	3	2
R/ M/ H	VAC		Remedial/Minor/Honours Course	3-1-0/ 4-0-0	4	4
TOTAL					27/31	23/27

SEMESTER VI						
Slot	Category Code	Course Number	Courses	L-T-P	Hours	Credit
A	PCC	EC1U30E	Electromagnetics	3-1-0	4	4
B	PCC	EC1U30F	VLSI Circuit Design	3-1-0	4	4
C	PCC	EC1U30G	Information Theory and Coding	3-1-0	4	4
D	PEC	EC1UXXX	Programme Elective I	2-1-0 /3-0-0	3	3
E 1/2	HSC	HS0U30A	Industrial Economics & Foreign Trade	3-0-0	3	3
		HS0U30B	Management for Engineers	3-0-0	3	3
F	PCC	EC1U30H	Comprehensive Course work	1-0-0	1	1
S	PCC	EC1U38C	Communication Lab	0-0-3	3	2
T	PWS	EC1U39A	Mini Project	0-0-3	3	2
R/ M/ H	VAC		Remedial/Minor/Honours Course	3-1-0/ 4-0-0	4	4
TOTAL					25/29	23/27



PROGRAMME ELECTIVE I

Slot	Category Code	Course Number	Courses	L-T-P	Hours	Credit
D	PEC	EC1U31A	Digital System Design	2-1-0	3	3
		EC1U31B	Power Electronics	3-0-0	3	3
		EC1U31C	Data Analysis	2-1-0	3	3
		EC1U31D	Embedded System	3-0-0	3	3
		EC1U31E	Digital Image Processing	2-1-0	3	3
		EC1U31F	Introduction to MEMS	2-1-0	3	3
		EC1U31G	Quantum Computing	2-1-0	3	3

SEMESTER VII						
Slot	Category Code	Course Number	Courses	L-T-P	Hours	Credit
A	PCC	EC1U40A	Microwaves and Antennas	2-1-0	3	3
B	PEC	EC1UXXX	Programme Elective II	2-1-0/ 3-0-0	3	3
C	OEC	EC0UXXX	Open Elective	2-1-0/ 3-0-0	3	3
D	MNC	NC0U40A	Industrial Safety Engineering	2-1-0	3	---
E	PCC	EC1U48A	Electromagnetics Lab	0-0-3	3	2
T	PWS	EC1U49A	Seminar	0-0-3	3	2
U	PWS	EC1U49B	Project Phase I	0-0-6	6	2
R/ M/ H	VAC		Remedial/Minor/Honours Course	0-1-6/ 4- 0-0	7/4	4
TOTAL					24/(3 1/28)	15/19

PROGRAMME ELECTIVE II

Slot	Category Code	Course Number	Courses	L-T-P	Hours	Credit
B	PEC	EC1U41A	Optical Fiber Communication	3-0-0	3	3
		EC1U41B	Computer Networks	3-0-0	3	3
		EC1U41C	Opto Electronic Devices	2-1-0	3	3
		EC1U41D	Instrumentation	2-1-0	3	3
		EC1U41E	Error Control Codes	2-1-0	3	3
		EC1U41F	Machine Learning	2-1-0	3	3
		EC1U41G	DSP Architectures	2-1-0	3	3

**OPEN ELECTIVE**

Slot	Category Code	Course Number	Courses	L-T-P	Hours	Credit
C	OEC	EC0U41A	Mechatronics	2-1-0	3	3
		EC0U41B	Biomedical Instrumentation	3-0-0	3	3
		EC0U41C	Electronic Hardware for Engineers	3-0-0	3	3
		EC0U41D	IoT and Applications	2-1-0	3	3
		EC0U41E	Entertainment Electronics	2-1-0	3	3

SEMESTER VIII							
Slot	Category Code	Course Number	Courses	L-T-P	Hours	Credit	
A	PCC	EC1U40B	Wireless Communication	3-0-0	3	3	
B	PEC	EC1UXXX	Programme Elective III	3-0-0/ 2-1-0	3	3	
C	PEC	EC1UXXX	Programme Elective IV	3-0-0/ 2-1-0	3	3	
D	PEC	EC1UXXX	Programme Elective V	3-0-0/ 2-1-0	3	3	
T	PCC	EC1U40C	Comprehensive Viva Voce	1-0-0	1	1	
U	PWS	EC1U49C	Project Phase II	0-0-12	12	4	
R/ M/ H	VAC		Remedial/Minor/Honours Course	0-1-6	7	4	
TOTAL						25/32	17/21

PROGRAMME ELECTIVE III

Slot	Category Code	Course Number	Courses	L-T-P	Hours	Credit
B	PEC	EC1U42A	Biomedical Engineering	3-0-0	3	3
		EC1U42B	Satellite Communication	3-0-0	3	3
		EC1U42C	Secure Communication	3-0-0	3	3
		EC1U42D	Pattern Recognition	3-0-0	3	3
		EC1U42E	RF Circuit Design	3-0-0	3	3
		EC1U42F	Mixed Signal Circuit Design	2-1-0	3	3
		EC1U42G	Entrepreneurship	3-0-0	3	3

**PROGRAMME ELECTIVE IV**

Slot	Category Code	Course Number	Courses	L-T-P	Hours	Credit
C	PEC	EC1U43A	Modern Communication Systems	3-0-0	3	3
		EC1U43B	Real Time Operating Systems	2-1-0	3	3
		EC1U43C	Adaptive Signal Processing	2-1-0	3	3
		EC1U43D	Microwave Devices and Circuits	3-0-0	3	3
		EC1U43E	Speech & Audio Processing	3-0-0	3	3
		EC1U43F	Analog CMOS Design	2-1-0	3	3
		EC1U43G	Robotics	3-0-0	3	3

PROGRAMME ELECTIVE V

Slot	Category Code	Course Number	Courses	L-T-P	Hours	Credit
D	PEC	EC1U44A	Mechatronics	3-0-0	3	3
		EC1U44B	Optimization Techniques	2-1-0	3	3
		EC1U44C	Computer Vision	2-1-0	3	3
		EC1U44D	Low Power VLSI	2-1-0	3	3
		EC1U44E	Internet of Things	2-1-0	3	3
		EC1U44F	Renewable Energy Systems	3-0-0	3	3
		EC1U44G	Organic Electronics	3-0-0	3	3



B. Tech (MINOR)

Semester	BASKET I				BASKET II				BASKET III			
	Course Number	Course	L-T-P	Credit	Course Number	Course	L-T-P	Credit	Course Number	Course	L-T-P	Credit
S3	ECOM 20A	Electronic Circuits	3-1-0	4	ECOM 20B	Analog Communication	4-0-0	4	ECOM 20C	Introduction to Signals and Systems	3-1-0	4
S4	ECOM 20D	Microcontrollers	3-1-0	4	ECOM 20E	Digital Communication	3-1-0	4	ECOM 20F	Introduction to Digital Signal Processing	3-1-0	4
S5	ECOM 30A	Embedded System Design	3-1-0	4	ECOM 30B	Communication Systems	4-0-0	4	ECOM 30C	Topics in Digital Image Processing	3-1-0	4
S6	ECOM 30D	VLSI Circuits	3-1-0	4	ECOM 30E	Data Networks	4-0-0	4	ECOM 30F	Topics in Computer Vision	3-1-0	4
S7	ECOM 49A	Mini Project	0-1-6	4	ECOM 49A	Mini Project	0-1-6	4	ECOM 49A	Mini Project	0-1-6	4
S8	ECOM 49B	Mini Project	0-1-6	4	ECOM 49B	Mini Project	0-1-6	4	ECOM 49B	Mini Project	0-1-6	4



B. Tech (HONOURS)

Semester	GROUP I				GROUP II				GROUP III			
	Course Number	Course	L-T-P	Credit	Course Number	Course	L-T-P	Credit	Course Number	Course	L-T-P	Credit
S4	EC1H 20A	Nanoelectronics	4-0-0	4	EC1H 20B	Stochastic Process for Communication	4-0-0	4	EC1H 20C	Stochastic Signal Processing	4-0-0	4
S5	EC1H 30A	FPGA based System Design	4-0-0	4	EC1H 30B	Detection and Estimation Theory	4-0-0	4	EC1H 30C	Computational Tools for Signal Processing	4-0-0	4
S6	EC1H 30D	Electronic Design and Automation Tools	4-0-0	4	EC1H 30E	MIMO and Multiuser Communication Systems	4-0-0	4	EC1H 30F	Detection and Estimation Theory	4-0-0	4
S7	EC1H 40A	RF MEMS	4-0-0	4	EC1H 40B	Design and Analysis of Antennas	4-0-0	4	EC1H 40C	Multirate Signal Processing and Wavelets	4-0-0	4
S8	EC1H 49A	Mini Project	0-1-6	4	EC1H 49A	Mini Project	0-1-6	4	EC1H 49A	Mini Project	0-1-6	4



SEMESTER - I



Course Code	Course Name	Category	L	T	P	Credit	Year of Introduction
MA0U10A	LINEAR ALGEBRA AND CALCULUS	BSC	3	1	0	4	2020

i) COURSE OVERVIEW

This course introduces students to some basic mathematical ideas and tools which are at the core of any engineering course. A brief course in Linear Algebra familiarises students with some basic techniques in matrix theory which are essential for analysing linear systems. The calculus of functions of one or more variables taught in this course are useful in modelling and analysing physical phenomena involving continuous change of variables or parameters and have applications across all branches of engineering.

ii) COURSE OUTCOMES

After the completion of the course, the student will be able to:

Course Outcomes	Description	Level
CO 1	Solve systems of linear equations.	Apply
CO 2	Compute maxima and minima using partial derivatives.	Evaluate
CO 3	Compute areas and volumes of geometrical shapes using multiple integrals.	Evaluate
CO 4	Identify the convergence or divergence of an infinite series.	Evaluate
CO 5	Determine the Taylor and Fourier series expansion of functions and learn their applications.	Apply

iii) SYLLABUS

Basics of Linear Algebra – Solution of systems of linear equations, row echelon form, rank, eigen values and eigen vectors, diagonalization of matrices, orthogonal transformation, quadratic forms.

Partial Differentiation and Applications – Limit and continuity of functions of two or more variables, partial derivatives, chain rule, total derivatives, maxima and minima.

Multiple Integrals – Double and triple integrals, double integrals over rectangular and non-rectangular regions, changing the order of integration, finding areas and volume, mass and centre of gravity.

Infinite series - Convergence and divergence of Infinite series, geometric series and p-series, test of convergence, Alternating series, absolute and conditional convergence
Taylor series, Binomial series and series representation of exponential, trigonometric, logarithmic functions-Fourier Series- Euler's formulas, Fourier sine and cosine series, Half range expansions

**iv) a) TEXT BOOKS**

- 1) H. Anton, I. Biven, S. Davis, *Calculus*, Wiley, 10th Edition, 2015.
- 2) Erwin Kreyszig, *Advanced Engineering Mathematics*, John Wiley & Sons, 10th Edition, 2016.

b) REFERENCES

- 1) J. Stewart, *Essential Calculus*, Cengage, 2nd Edition, 2017.
- 2) G. B. Thomas and R. L. Finney, *Calculus and Analytic geometry*, 9th Edition, Pearson, Reprint, 2002.
- 3) Peter V. O'Neil, *Advanced Engineering Mathematics*, Cengage, 7th Edition 2012.

v) COURSE PLAN

Module	Contents	No. of hours
I	Linear Algebra: Systems of linear equations, Solution by Gauss elimination, row echelon form and rank of a matrix, fundamental theorem for linear systems (homogeneous and non-homogeneous, without proof), Eigen values and eigen vectors. Diagonalization of matrices, orthogonal transformation, quadratic forms and their canonical forms.	12
II	Multivariable calculus-Differentiation: Concept of limit and continuity of functions of two variables, partial derivatives, Differentials, Local Linear approximations, chain rule, total derivative, Relative maxima and minima, Absolute maxima and minima on closed and bounded set.	12
III	Multivariable calculus-Integration: Double integrals (Cartesian), reversing the order of integration, change of coordinates (Cartesian to polar), finding areas and volume using double integrals, mass and centre of gravity of inhomogeneous laminas using double integral. Triple integrals, volume calculated as triple integral, triple integral in cylindrical and spherical coordinates (computations involving spheres, cylinders).	12
IV	Sequences and Series: Convergence of sequences and series, convergence of geometric series and p-series(without proof), test of convergence (comparison, ratio and root tests without proof); Alternating series and Leibnitz test, absolute and conditional convergence.	12
V	Series representation of functions: Taylor series (without proof, assuming the possibility of power series expansion in appropriate domains), Binomial series and series representation of exponential, trigonometric, logarithmic functions (without proofs of convergence); Fourier series, Euler formulas, Convergence of Fourier series (without proof), half range sine and cosine series, Parseval's theorem (without proof).	12
	Total hours	60

**vi) ASSESSMENT PATTERN****Mark distribution**

Total Marks	Continuous Internal Evaluation Marks	End Semester Evaluation Marks	End Semester Examination Duration
150	50	100	3 Hours

Continuous Internal Evaluation Pattern:

Attendance	10 Marks
Continuous Assessment Tests (2 numbers)	25 Marks
Assignment/Quiz/Course project	15 Marks

End Semester Examination Pattern:

There will be two parts; Part A and Part B. Part A contain 10 questions with 2 questions from each module, having 3 marks for each question. Students should answer all questions. Part B contains 2 questions from each module of which student should answer any one. Each question can have maximum 2 sub-divisions and carry 14 marks.



Course Code	Course Name	Category	L	T	P	Credit	Year of Introduction
PH0U10A	ENGINEERING PHYSICS-A (FOR CIRCUIT BRANCHES)	BSC	3	1	0	4	2020

i) COURSE OVERVIEW

The aim of the course is to develop scientific attitude in students and offer them an understanding of physical concepts behind various engineering applications. It creates an urge in students to think creatively in emerging areas of Physics.

ii) COURSE OUTCOMES

After the completion of the course, the student will be able to:

Course Outcomes	Description	Level
CO 1	Describe the characteristics of different types of oscillations and waves.	Remember
CO 2	Apply the principles of wave optics to explain natural physical processes and related technological advances.	Understand
CO 3	Use the principles of quantum mechanics to analyse the behaviour of matter in the atomic and subatomic level	Understand
CO 4	Apply the fundamental ideas of magnetism and vector calculus to arrive at Maxwell's equations.	Understand
CO 5	Describe the principles behind various superconducting applications, solid-state lighting devices and fibre optic communication system.	Apply

iii) SYLLABUS

Oscillations and Waves: Damped oscillations, Forced oscillations, One dimensional and three-dimensional wave equations, Transverse vibrations along a stretched string

Wave Optics: Interference of light- Air wedge, Newton's rings, Antireflection coating, Diffraction-Fraunhofer diffraction at a single slit, Grating equation, Rayleigh's criterion

Quantum Mechanics & Nano technology: Wave function, Time dependent and time independent Schrodinger wave equations, One-dimensional potential well, Introduction to nanoscience and technology, Quantum confinement, Properties of nanomaterials

Magnetism & Electro Magnetic Theory: Magnetic field and Magnetic flux density, fundamental laws, magnetic permeability and susceptibility, classification of magnetic materials, fundamentals of vector calculus and theorems, equation of continuity, Maxwell's equations in vacuum, velocity of electromagnetic waves in freespace.

Superconductivity & Photonics: Super conductivity- Meissner effect, Type I & II superconductors, applications of superconductors, Introduction to photonics-photonics devices-Light Emitting Diode, Photo detectors -Junction and PIN photodiodes, Solar cells-I-V characteristics, Optical fibre -Principle, Numerical aperture, Types of fibres, Applications

**iv) (a) TEXT BOOKS**

- 1) M.N. Avadhanulu , P.G. Kshirsagar, T.V.S Arun Murthy, *A Text book of Engineering Physics*, S.Chand &Co., Revised Edition, 2014
- 2) H.K. Malik, A.K. Singh, *Engineering Physics*, McGraw Hill Education, 2nd Edition, 2017

(b) REFERENCES

- 3) Arthur Beiser, *Concepts of Modern Physics*, Tata McGraw Hill Publications, 6th Edition, 2003.
- 4) Aruldas G., *Engineering Physics*, Prentice Hall of India Pvt. Ltd., 2015
- 5) Ajoy Ghatak, *Optics*, Mc Graw Hill Education, 6th Edition, 2017
- 6) David J. Griffiths, *Introduction to Electrodynamics*, Pearson, 4th Edition, 2013.
- 7) Premlet B., *Advanced Engineering Physics*, Phasor Books, 10th Edition, 2017.

v) COURSE PLAN

Module	Contents	No. of hours
I	Oscillations and Waves: Harmonic oscillations, damped harmonic motion-derivation of differential equation and its solution, over damped, critically damped and under damped cases, Quality factor-expression, forced oscillations-differential equation-derivation of expressions for amplitude and phase of forced oscillations, amplitude resonance-expression for resonant frequency, Quality factor and sharpness of resonance, electrical analogy of mechanical oscillators Wave motion- derivation of one-dimensional wave equation and its solution, three-dimensional wave equation and its solution (no derivation), distinction between transverse and longitudinal waves, transverse vibration in a stretched string, statement of laws of vibration	12
II	Wave Optics: Interference of light-principle of superposition of waves, theory of thin films - cosine law (Reflected system), derivation of the conditions of constructive and destructive interference, interference due to wedge shaped films -determination of thickness and test for optical planeness, Newton's rings- measurement of wavelength and refractive index, antireflection coatings. Diffraction of light, Fresnel and Fraunhofer classes of diffraction, diffraction grating-Grating equation, Rayleigh criterion for limit of resolution, resolving and dispersive power of a grating with expression (no derivation)	12
III	Quantum Mechanics & Nanotechnology: Introduction for the need of Quantum mechanics, wave nature of Particles, uncertainty principle, Applications-absence of electrons inside a nucleus and natural line broadening mechanism, formulation of time dependent and independent Schrodinger wave equations-physical meaning of wave function, Particle in a one dimensional box- derivation for normalised wave function and energy eigen values, Quantum mechanical tunnelling (qualitative). Introduction to nanoscience and technology, increase in surface to volume ratio for nanomaterials, quantum confinement in one dimension, two dimension and three dimension-nano sheets, nano wires and quantum dots, properties of nanomaterials-mechanical, electrical and optical,	12



	applications of nanotechnology (qualitative ideas)	
IV	Magnetism and Electromagnetic theory: Magnetic field and Magnetic flux density, Gauss's law for Magnetic flux density, Ampere's Circuital law, Faraday's law in terms of emf produced by changing magnetic flux, Magnetic permeability and susceptibility, classification of magnetic materials-para, dia and ferromagnetic materials Fundamentals of vector calculus, concept of divergence, gradient and curl along with physical significance, line, surface and volume integrals, Gauss divergence theorem & Stokes' theorem, equation of continuity, derivation of Maxwell's equations in vacuum, comparison of displacement current with conduction current, electromagnetic waves, velocity of electromagnetic waves in free space, flow of energy and Poynting's vector (no derivation)	12
V	Superconductivity & Photonics: Superconducting phenomena, Meissner effect and perfect diamagnetism, types of superconductors-Type I and Type II, BCS Theory (Qualitative), high temperature superconductors-applications of super conductivity Introduction to photonics-photonic devices-Light Emitting Diode, Photo detectors -Junction and PIN photodiodes, Solar cells-I-V characteristics, Optic fibre-principle of propagation of light, types of fibres-step index and graded index fibres, numerical aperture –derivation, fibre optic communication system (block diagram), industrial, medical and technological applications of optical fibre, fibre optic sensors-intensity modulated and phase modulated sensors.	12
	Total hours	60

vi) ASSESSMENT PATTERN**Mark distribution**

Total Marks	Continuous Internal Evaluation Marks	End Semester Evaluation Marks	End Semester Examination Duration
150	50	100	3 Hours

Continuous Internal Evaluation Pattern:

Attendance	10 Marks
Continuous Assessment Tests (2 numbers)	25 Marks
Assignment/Quiz/Course project	15 Marks

End Semester Examination Pattern:

There will be two parts; Part A and Part B. Part A contain 10 questions with 2 questions from each module, having 3 marks for each question. Students should answer all questions. Part B contains 2 questions from each module of which student should answer any one. Each question can have maximum 2 sub-divisions and carry 14 marks.



Course Code	Course Name	Category	L	T	P	Credit	Year of Introduction
ES0U10A	ENGINEERING MECHANICS	ESC	2	1	0	3	2020

i) COURSE OVERVIEW

Goal of this course is to expose the students to the fundamental concepts of mechanics and enhance their problem-solving skills. It introduces students to the influence of applied force system and the geometrical properties of the rigid bodies while stationary or in motion. After this course students will be able to recognize similar problems in real-world situations and respond accordingly.

ii) COURSE OUTCOMES

After the completion of the course, the student will be able to:

Course Outcomes	Description	Level
CO 1	Explain the principles and theorems related to rigid body mechanics.	Understand
CO 2	Describe the components of system of forces acting on the rigid body.	Understand
CO 3	Apply the properties of distributed areas and masses for solving problems involving rigid bodies.	Apply
CO 4	Apply the conditions of equilibrium to various practical problems involving different force systems.	Apply
CO 5	Apply appropriate principles to solve problems in rigid body mechanics.	Apply

iii) SYLLABUS

Statics of rigid bodies: Classification of force systems, Composition and resolution of forces, Resultant and equilibrium equations, Methods of projections, Varignon's Theorem of moments.

Friction: Analysis of single and connected bodies. Parallel coplanar forces, couple. Beam reactions.

Properties of surfaces: Centroid of composite areas, Moment of inertia of areas, Polar moment of inertia, Theorem of Pappus-Guldinus, Forces in space.

Dynamics: D'Alembert's principle, Motion on horizontal and inclined surfaces, Motion of connected bodies. Impulse momentum and work energy relation. Curvilinear translation.

Rotation: Kinematics of rotation. Plane motion of rigid body: Instantaneous centre. Simple harmonic motion: Mechanical vibrations.

iv) (a) TEXTBOOKS

- 1) Timoshenko, S., Young, D. H., Rao, J. V. and Pati, S., *Engineering Mechanics*, McGraw Hill Publishers, 2017.
- 2) Beer, F. P. and Johnston, R., *Vector Mechanics for Engineers: Statics and Dynamics*, Tata Mc-Graw Hill Publishing Company Limited, New Delhi, 12th Edition, 2005.
- 3) Bansal, R. K., *A Textbook of Engineering Mechanics*, Laxmi Publications, 8th Edition, 2016.
- 4) Sharma, D. P., Hibbeler, R. C. and Shames, I. H., *Engineering Mechanics*, Pearson Publishers, 2011.



(b) REFERENCES

- 1) Bhavikkatti, S. S., *Engineering Mechanics*, New Age International Publishers, 2016.
- 2) Merriam, J. L. and Kraige, L. G., *Engineering Mechanics - Vols. 1 and 2*, John Wiley, 7th Edition, 2006.
- 3) Hibbeler, R. C. and Gupta, A., *Engineering Mechanics*, Vol. I Statics, Vol II Dynamics, Pearson Education, 2009.
- 4) Shames, I. H., *Engineering Mechanics - Statics and Dynamics*, Prentice Hall of India, 4th Edition 2005.

v) COURSE PLAN

Module	Contents	No. of hours
I	<p>Introduction to engineering mechanics - Introduction on statics and dynamics - Basic principles of statics - Parallelogram law, Equilibrium law - Superposition and transmissibility, Law of action and reaction.</p> <p>Free body diagrams - Degree of freedom-Types of supports and nature of reactions -Exercises for free body diagram preparation - Composition and resolution of forces, Resultant and equilibrium equations.</p> <p>Concurrent coplanar forces - Analysis of concurrent forces - Methods of projections - Methods of moment - Varignon’s Theorem of Moments.</p>	9
II	<p>Friction - Sliding friction - Coulomb’s laws of friction - Analysis of single bodies - Analysis of connected bodies.</p> <p>Parallel coplanar forces - Couple - Resultant of parallel forces - Centre of parallel forces - Equilibrium of parallel forces - Simple beam subject to concentrated vertical loads. General coplanar force system - Resultant and equilibrium equations.</p>	9
III	<p>Centroid of regular geometrical shapes - Centroid of Composite areas.</p> <p>Moment of inertia- Parallel axis theorem - Perpendicular axis theorem - Polar moment of inertia, Radius of gyration. Mass moment of inertia of ring, cylinder and uniform disc. Theorem of Pappus Guldinus.</p> <p>Introduction to forces in space -Vectorial representation of forces, moments and couples - Resultant and equilibrium equations for concurrent forces in space - Concurrent forces in space.</p>	9
IV	<p>Introduction to dynamics - Rectilinear translation - Equations of kinematics.</p> <p>Introduction to kinetics - Equation of motion - D’Alembert’s principle - Motion on horizontal and inclined surfaces - Motion of connected bodies.</p> <p>Curvilinear translation - Projectile motion - Introduction to kinetics - equation of motion. Impulse momentum equation and work energy equation. Moment of momentum and work energy equation (Curvilinear translation).</p>	9
V	<p>Rotation - Kinematics of rotation- Equation of motion for a rigid body rotating about a fixed axis - Rotation under a constant moment.</p> <p>Plane motion of rigid body- Instantaneous centre of rotation (concept</p>	9



	only). Introduction to harmonic oscillation - Free vibrations - Simple harmonic motion – Differential equation and solution. Degree of freedom - Examples of single degree of freedom (SDOF) systems -Idealisation of mechanical systems as spring-mass systems (concept only). SDOF spring mass system - Equation of motion -Undamped free vibration response - Concept of natural frequency. Effect of damping on free vibration response (concept only).	
	Total hours	45

vi) ASSESSMENT PATTERN**Mark distribution**

Total Marks	Continuous Internal Evaluation Marks	End Semester Evaluation Marks	End Semester Examination Duration
150	50	100	3 Hours

Continuous Internal Evaluation Pattern:

Attendance	10 Marks
Continuous Assessment Tests (2 numbers)	25 Marks
Assignment/Quiz/Course project	15 Marks

End Semester Examination Pattern:

There will be two parts; Part A and Part B. Part A contain 10 questions with 2 questions from each module, having 3 marks for each question. Students should answer all questions. Part B contains 2 questions from each module of which student should answer any one. Each question can have maximum 2 sub-divisions and carry 14 marks.



Course Code	Course Name	Category	L	T	P	Credit	Year of Introduction
ES0U10C	BASICS OF CIVIL AND MECHANICAL ENGINEERING	ESC	4	0	0	4	2020

i) COURSE OVERVIEW

The goal of this course is to provide an insight on the essentials of Civil and Mechanical Engineering discipline to the students of all branches of Engineering and to provide the students an illustration of the significance of the Civil and Mechanical Engineering Profession in satisfying the societal needs.

ii) COURSE OUTCOMES

After the completion of the course, the student will be able to:

Course Outcomes	Description	Level
CO 1	Explain different types of buildings, their components, materials, construction techniques and basic infrastructure services.	Understand
CO 2	Describe the importance, objectives and principles of surveying.	Understand
CO 3	Apply the principles of levelling to find the level difference between points.	Apply
CO 4	Summarise the different materials and systems in the context of green buildings.	Understand
CO 5	Analyse thermodynamic cycles and Illustrate the working and features of IC Engines	Apply
CO 6	Explain the basic principles of Refrigeration and Air Conditioning and working of hydraulic machines	Understand
CO 7	Explain the working of power transmission elements, basic manufacturing, metal joining and machining processes	Understand

iii) SYLLABUS

Introduction to Civil Engineering: Relevance and major disciplines of Civil Engineering, Introduction to buildings: Types and different components of buildings, Building rules and regulations, Building area.

Introduction to surveying: Objectives, Principle, Classification, Levelling, Introduction to modern surveying instrument- Total Station.

Construction materials: Bricks, Stones, Sand, Timber, Cement, Cement mortar, Concrete, Steel, Modern construction materials.

Building construction: Foundations, Brick masonry, Roofs and floors, Basic infrastructure services, Green buildings.

Basics of Mechanical Engineering: Fundamental of thermodynamics. Analysis of thermodynamic cycles and working of internal combustion engines. CRDI, MPFI and concept of hybrid vehicles.

Refrigeration and power transmission systems - Analysis of reversed Carnot cycle and vapour compression cycle. Introduction to psychrometry. Layout of unit and central air conditioner.



Description and basic analysis of hydraulic pump and turbine. Working of different power transmission devices.

Manufacturing methods and machine tools - Description of various manufacturing, metal joining process and basic machining operations.

Working of different machines tools and CNC machine. Introduction to CAD/CAM, additive and rapid manufacturing.

iv) (a) TEXT BOOKS

- 1) Mamlouk, M. S., and Zaniewski, J. P., *Materials for Civil and Construction Engineering*, Pearson Publishers, 4th Edition, 2017.
- 2) Rangwala, S. C., *Essentials of Civil Engineering*, Charotar Publishing House, 1st Edition, 2012.
- 3) Clifford, M., Simmons, K. and Shipway, P., *An Introduction to Mechanical Engineering Part I* - CRC Press, 2009.
- 4) Kumar, P., *Basic Mechanical Engineering*, Pearson India, 2013.

(b) REFERENCES

- 1) Chen, W. F. and Liew, J. Y. R. (Eds), *The Civil Engineering Handbook*, CRC Press (Taylor and Francis), 2nd Edition, 2002
- 2) Punmia, B. C., Ashok, K. J. and Arun, K. J., *Surveying*, Vol. I, Laxmi Publications (P) Ltd., New Delhi, 17th Edition, 2016
- 3) *Kerala Municipal Building Rules*, LSGD, Govt. of Kerala, 2019
- 4) SP 7: 2016, *National Building Code of India*, BIS, New Delhi, 2016.
- 5) Wylen, G. J. V., Sonntag, R. and Borgnakke, C., *Fundamentals of Classical Thermodynamics*, John Wiley & Sons, 2012.
- 6) Sawhney, G. S., *Fundamentals of Mechanical Engineering*, PHI Learning; 3rd Revised Edition, 2015.

v) COURSE PLAN

Module	Contents	No. of hours
I	<p>General Introduction to Civil Engineering: Relevance of Civil Engineering in the overall infrastructure development of the Country. Responsibility of an engineer in ensuring the safety of built environment. Brief introduction to major disciplines of Civil Engineering like Structural Engineering, Transportation Engineering, Geotechnical Engineering, Water Resources Engineering and Environmental Engineering.</p> <p>Introduction to buildings: Types of buildings, selection of site for buildings, components of a residential building and their functions.</p> <p>Building rules and regulations: Relevance of NBC, KBR & CRZ norms (brief discussion only).</p> <p>Building area: Plinth area, built up area, floor area, carpet area and floor area ratio for a building as per KBR.</p> <p>Surveying: Importance, classification, objectives and principles, instruments used. Levelling- principles, dumpy level, simple levelling,</p>	10



	differential levelling- problems. Introduction to modern surveying instruments-Total Station.	
II	<p>Construction materials: Conventional construction materials: types, properties and uses of building materials: bricks, stones, cement, sand and timber.</p> <p>Cement Mortar: Materials and properties.</p> <p>Cement concrete: Constituent materials, properties and types.</p> <p>Steel: Steel sections and steel reinforcements, types and uses.</p> <p>Modern construction materials: Architectural glass, ceramics, plastics, composite materials, thermal and acoustic insulating materials, decorative panels, waterproofing materials. Modern uses of gypsum, pre-fabricated building components (brief discussion only).</p>	10
III	<p>Building Construction: Foundations: Bearing capacity of soil (definition only), functions of foundations, types – shallow and deep (brief discussion only). Load bearing and framed structures (concept only).</p> <p>Brick masonry: Header and stretcher bond, English bond and Flemish bond.</p> <p>Roofs and floors: Functions, types; flooring materials (brief discussion only).</p> <p>Basic infrastructure services: MEP, HVAC, elevators, escalators and ramps (Civil Engineering aspects only), fire safety for buildings.</p> <p>Green buildings: Materials, energy systems and water management and environment for green buildings (brief discussion only).</p>	10
IV	<p>Fundamentals of thermodynamics: Review of basics of thermodynamics- system, surroundings, process, cycle- quasistatic process, laws of thermodynamics.</p> <p>Analysis of thermodynamic cycles: Carnot, Otto, Diesel cycles, Derivation of efficiency of these cycles, Problems to calculate heat added, heat rejected, net-work and efficiency.</p> <p>IC Engines: CI, SI, 2- Stroke, 4-Stroke engines. Listing the parts of different types of IC Engines. Efficiencies of IC Engines (Definitions only), Air, Fuel, cooling and lubricating systems in SI and CI Engines, CRDI, MPFI. Concept of hybrid engines.</p>	10
V	<p>Refrigeration: Unit of refrigeration, reversed Carnot cycle, COP, vapour compression cycle (only description and no problems); Definitions of dry, wet & dew point temperatures, specific humidity and relative humidity, Cooling and dehumidification, Layout of unit and central air conditioners.</p> <p>Hydraulic machines: Working principle of Reciprocating pump, Centrifugal pump, Pelton turbine, Francis turbine and Kaplan turbine. Overall efficiency, Problems on calculation of input and output power of pumps and turbines (No velocity triangles)</p> <p>Power Transmission Devices: Belt and Chain drives, Gear and Gear trains, Single plate clutches.</p>	10
VI	<p>Manufacturing Process: Basic description of the manufacturing processes – Sand Casting, Forging, Rolling, Extrusion and their applications. Metal Joining Processes: List types of welding, Description with sketches of Arc Welding, Soldering and Brazing and their applications.</p> <p>Basic Machining Operations: Turning, Drilling, Milling and Grinding. Lathe, Drilling machine, Milling machine.</p> <p>Computer Aided Machining: CNC Machine. Principle of CAD/CAM, Rapid and Additive manufacturing.</p>	10
	Total hours	60

**vi) ASSESSMENT PATTERN****Mark distribution**

Total Marks	Continuous Internal Evaluation Marks	End Semester Evaluation Marks	End Semester Examination Duration
150	50	100	3 Hours

Continuous Internal Evaluation Pattern:

Attendance	10 Marks
Continuous Assessment Tests (2 numbers)	25 Marks
Assignment/Quiz/Course project	15 Marks

End Semester Examination Pattern:

There will be two parts; Part I – Basic Civil Engineering and Part II – Basic Mechanical Engineering. Part I and PART II carries 50 marks each. For the end semester examination, part I contain 2 parts - Part A and Part B. Part A contain 5 questions carrying 4 marks each (not exceeding 2 questions from each module). Part B contains 2 questions from each module out of which one to be answered. Each question carries 10 mark and can have maximum 2 sub-divisions. The pattern for end semester examination for part II is same as that of part I. However, student should answer both part I and part 2 in separate answer booklets.



Course Code	Course Name	Category	L	T	P	Credit	Year of Introduction
HS0U10A	LIFE SKILLS	HSC	2	0	2	-	2020

i) COURSE OVERVIEW

This course is designed to enhance the employability and maximize the potential of the students by introducing them to the principles that underly personal and professional success, and help them acquire the skills needed to apply these principles in their lives and careers.

ii) COURSE OUTCOMES

After the completion of the course, the student will be able to:

Course Outcomes	Description	Level
CO 1	Identify different skills required in personal and professional life.	Understand
CO 2	Apply well defined techniques to cope with emotions and stress and to provide an awareness of the self.	Apply
CO 3	Apply appropriate thinking tools and techniques for creative problem solving.	Apply
CO 4	Explain the importance of teamwork, team performance, team conflicts and leadership.	Understand
CO 5	Explain the basic mechanics of effective communication and demonstrate these through presentations.	Understand

iii) SYLLABUS

Overview of Life Skills: Meaning and significance of life skills, Life skills identified by WHO, Life skills for professionals, personality development, IQ, EQ, and SQ.

Self-awareness & Stress Management: Definition and need for self-awareness; Tools and techniques of SA, Stress, reasons and effects, the four A's of stress management, Techniques and Approaches, PATH method and relaxation techniques.

Critical Thinking & Problem Solving: Creativity, Lateral thinking, Critical thinking, Multiple Intelligence, Problem Solving, Six thinking hats, Mind Mapping & Analytical Thinking.

Teamwork: Groups, Teams, Group Vs Teams, Team formation process, Stages of Group, Group Dynamics, Managing Team Performance & Team Conflicts.

Leadership Skills: Leadership, Levels of Leadership, Making of a leader, Types of leadership, Transactions Vs Transformational Leadership, VUCA Leaders, Leadership Grid & leadership Formulation.

iv) (a) TEXT BOOKS

- 1) Remesh S., Vishnu R. G., *Life Skills for Engineers*, Ridhima Publications, 1stEdition,2016.
- 2) *Life Skills for Engineers*, Compiled by ICT Academy of Kerala, McGraw Hill Education (India) Private Ltd., 2016.



(b) REFERENCES

- 1) Shiv Khera, *You Can Win*, Macmillan Books, NewYork,2003.
- 2) Barun K. Mitra, *Personality Development & Soft Skills*, Oxford Publishers, Third impression, 2017.
- 3) Caruso, D. R. and Salovey P, *The Emotionally Intelligent Manager: How to Develop and Use the Four Key Emotional Skills of Leadership*, John Wiley & Sons,2004.
- 4) Larry James, *The First Book of Life Skills*; Embassy Books, 1stEdition,2016.

v) COURSE PLAN

Module	Contents	No. of hours
I	<p>Overview of Life Skills: Meaning and significance of life skills</p> <p>Life skills identified by WHO: Self- awareness, Empathy, Critical thinking, Creative thinking, Decision making, problem solving, Effective communication, interpersonal relationship, coping with stress, coping with emotion.</p> <p>Life skills for professionals: positive thinking, right attitude, attention to detail, having the big picture, learning skills, research skills, perseverance, setting goals and achieving them, helping others, leadership, motivation, self-motivation, and motivating others, personality development, IQ, EQ, and SQ.</p>	6
	Activities based on Creative thinking tools	
II	<p>Self-awareness: Definition, need for self-awareness; Coping With Stress and Emotions, Human Values, tools and techniques of SA: questionnaires, journaling, reflective questions, meditation, mindfulness, psychometric tests, feedback.</p> <p>Stress Management: Stress, reasons and effects, identifying stress, stress diaries, the four A's of stress management, techniques, Approaches: action-oriented, emotion-oriented, acceptance- oriented, resilience, Gratitude Training,</p> <p>Coping with emotions: Identifying and managing emotions, harmful ways of dealing with emotions, PATH method and relaxation techniques.</p> <p>Morals, Values and Ethics: Integrity, Civic Virtue, Respect for Others, Living Peacefully. Caring, Sharing, Honesty, Courage, Valuing Time, Time management, Cooperation, Commitment, Empathy, Self-Confidence, Character, Spirituality, Avoiding Procrastination, Sense of Engineering Ethics.</p>	6
	Case studies on Morals and Ethics	
III	<p>21st century skills: Creativity, Critical Thinking, Collaboration, Problem Solving, Decision Making, Need for Creativity in the 21st century, Imagination, Intuition, Experience, Sources of Creativity, Lateral Thinking, Myths of creativity, Critical thinking Vs Creative thinking, Functions of Left Brain & Right brain, Convergent & Divergent Thinking, Critical reading & Multiple Intelligence.</p> <p>Steps in problem solving: Problem Solving Techniques, Six Thinking Hats, Mind Mapping, Forced Connections. Analytical Thinking, Numeric, symbolic, and graphic reasoning. Scientific temperament and</p>	6



	Logical thinking Thinking Hats, Mind Mapping, Forced Connections.	
	Problem solving using Mind map/Six Thinking Hats	
IV	Group and Team Dynamics: Introduction to Groups: Composition, formation, Cycle, thinking, clarifying expectations, Problem Solving, Consensus, Dynamics techniques, Group vs Team, Team Dynamics, Virtual Teams. Managing team performance and managing conflicts, Intrapreneurship.	6
	Group Discussion: Differences between group discussion and debate; Ensuring success in group discussions.	
V	Leadership: Leadership framework, entrepreneurial and moral leadership, vision, cultural dimensions. Growing as a leader, turnaround leadership, managing diverse stakeholders, crisis management. Types of Leadership, Traits, Styles, VUCA Leadership, Levels of Leadership, Transactional vs Transformational Leaders, Leadership Grid, Effective Leaders.	6
	Presentation Presentation Skills: Oral presentation and public speaking skills; business presentations	
	Total hours	30

Life skills: Practical part – 15 hours

1. Activities based on Creative thinking tools- 3 hours
2. Case studies on Morals and Ethics- 3hours
3. Problem solving using Mind map/Six Thinking Hats- 3 hours
4. Group Discussion: Differences between group discussion and debate; Ensuring success in group discussions.- 3 hours
5. Oral presentation and public speaking skills; business presentations- 3 hours

vi) ASSESSMENT PATTERN

Mark distribution

Total Marks	Continuous Internal Evaluation Marks	End Semester Evaluation Marks	End Semester Examination Duration
100	50	50	2 Hours

Continuous Internal Evaluation Pattern:

Attendance	10 Marks
Continuous Assessment Tests (One test only, should include first three modules)	25 Marks
Regular assessment	15 Marks



Regular assessment:

Group Discussion (Marks: 9)

Create groups of about 6 students each and engage them on a GD on a suitable topic for about 20 minutes. Parameters to be used for evaluation are as follows:

- **Communication Skills** :3 marks
- **Subject Clarity** :2marks
- **Group Dynamics** :2 marks
- **Behaviours & Mannerisms** :2 marks
-

Presentation Skills (Marks: 6)

Identify a suitable topic and ask the students to

Prepare a presentation (preferably a power point presentation) for about 10 minutes. Parameters to be used for evaluation are as follows:

- **Communication Skills** :2 marks
- **Platform Skills** :2 marks
- **Subject Clarity/Knowledge** :2 marks

End Semester Examination Pattern:

There will be two parts; Part A and Part B.

Part A: There will be one question from each MODULE (five questions in total, five marks each). Each question should be written in about maximum of 400 words. Parameters to be used for evaluation are as follows;

- (i) Content Clarity/Subject Knowledge
- (ii) Presentation style
- (iii) Organization of content

Part B: The students will be given a case study with questions at the end the students have to analyze the case and answer the question at the end. Parameters to be used for evaluation are as follows;

- (i) Analyze the case situation
- (ii) Key players/characters of the case
- (iii) Identification of the problem (both major & minor if exists)
- (iv) Bring out alternatives
- (v) Analyze each alternative against the problem
- (vi) Choose the best alternative
- (vii) Implement as solution
- (viii) Conclusion
- (ix) Answer the question at the end of the case



Course Code	Course Name	Category	L	T	P	Credit	Year of Introduction
PH0U18A	ENGINEERING PHYSICS LAB	BSC	0	0	2	1	2020

i) COURSE OVERVIEW:

The aim of this course is to enable the students to gain practical knowledge in Physics to correlate with the theoretical studies. It equips the students to utilize the acquired skills in an appropriate way to explore the prospects of modern technology. It brings more confidence in students and develop the ability to fabricate engineering and technical tools.

ii) COURSE OUTCOMES

After the completion of the course, the student will be able to:

Course Outcomes	Description	Level
CO 1	Determine the frequency of tuning fork using a Melde's string apparatus by setting up wave pattern in a stretched string.	Understand
CO 2	Examine wave patterns using CRO to measure basic physical quantities viz. frequency and amplitude.	Remember
CO 3	Determine the wavelength of a monochromatic beam of light and thickness of thin wire using principle of interference	Apply
CO 4	Demonstrate diffraction of light using plane transmission grating.	Understand
CO 5	Draw the I-V characteristics of non ohmic devices.	Remember

iii) SYLLABUS

- Melde's string apparatus- Measurement of frequency in the transverse mode.
- Wave length measurement of a monochromatic source of light using Newton's Rings method.
- Determination of diameter of a thin wire or thickness of a thin strip of paper using air wedge method.
- Measurement of wavelength of a source of light using grating.
- Determination of dispersive power and resolving power of a plane transmission grating.
- Determination of the wavelength of any standard laser using diffraction grating
- I-V characteristics of solar cell.
- CRO-Measurement of frequency and amplitude of wave forms.

iv) REFERENCES

- S.L. Gupta and V. Kumar, *Practical physics with viva voce*, Pragati Prakashan Publishers, Revised Edition, 2009.
- M.N. Avadhanulu, A.A. Dani and Pokely P.M., *Experiments in Engineering Physics*, S. Chand &Co, 2008.
- S. K. Gupta, *Engineering Physics practicals*, Krishna Prakashan Pvt. Ltd., 2014
- P. R. Sasikumar, *Practical Physics*, PHI Ltd., 2011.

**v) ASSESSMENT PATTERN****Mark distribution**

Total Marks	Continuous Internal Evaluation Marks	End Semester Evaluation Marks	End Semester Examination Duration
100	70	30	1 Hour

Continuous Internal Evaluation Pattern

Attendance	20 Marks
Class work/ Assessment /Viva-voce	50 Marks

End Semester Examination Pattern: Written Objective Examination of one hour.



Course Code	Course Name	Category	L	T	P	Credit	Year of Introduction
ES0U18A	CIVIL AND MECHANICAL WORKSHOP	ESC	0	0	2	1	2020

i) COURSE OVERVIEW

The course is designed to train the students to identify and manage the tools, materials and methods required to execute basic Civil and Mechanical Engineering activities. Students will be introduced to a team working environment where they develop the necessary skills for planning, preparing and executing a basic Engineering activity. It also enables the student to familiarize various tools, measuring devices, practices and different methods of manufacturing processes employed in industry for fabricating components.

ii) COURSE OUTCOMES

After the completion of the course, the student will be able to:

Course Outcomes	Description	Level
CO 1	Name different devices and tools used for Civil Engineering measurements.	Remember
CO 2	Explain the use of various techniques and devices used in Civil Engineering measurements.	Understand
CO 3	Choose materials and methods required for basic Civil Engineering activities like field measurements, masonry work and plumbing.	Apply
CO 4	Demonstrate the steps involved in basic Civil Engineering activities like plot measurement, setting out operation, evaluating the natural profile of land, plumbing and undertaking simple construction work.	Apply
CO 5	Identify the tools and equipment used in fitting, carpentry, sheet metal, foundry, welding and smithy and various machine tools.	Remember
CO 6	Prepare simple models in fitting, carpentry, sheet metal, foundry, welding and smithy trades.	Apply
CO 7	Demonstrate general safety precautions in different mechanical workshop trades.	Understand

iii) SYLLABUS

A) CIVIL WORKSHOP

- 1) Set out a one room building of given plan using tape only method and using tape and cross staff.
- 2)
 - a) Use screw gauge and vernier calliper to measure the diameter of a steel rod and thickness of a flat bar.
 - b) Calculate the area of a built-up space and a small piece of land- Use standard measuring tape and digital distance measuring devices.
- 3)
 - a) Construct a wall using currently used building blocks such as bricks (1 ½ thick brick wall using English bond), hollow blocks, solid blocks, etc. Use spirit level to assess the tilt of walls.
 - b) Estimate the number of different types of building blocks required to construct a wall of given dimensions.



- c) Transfer the level from one point to another point using a water level.
- 4) Find the level difference between any two points using dumpy level (differential levelling).
- 5) a) Introduce the students to plumbing tools, different types of pipes, types of connections, traps, valves, fixtures and sanitary fittings.
b) Study of installation of rain water harvesting system in an educational campus.
- 6) Introduce students to the principle and working of Total Station.
- 7) Demonstration of a simple construction work using concrete.

B) MECHANICAL WORKSHOP

- 1) General: Introduction to workshop practice, Safety precautions, Shop floor ethics, Basic First Aid knowledge, Study of mechanical tools
- 2) Carpentry: Understanding of carpentry tools and making minimum one model.
- 3) Foundry: Understanding of foundry tools and making minimum one model.
- 4) Sheet metal: Understanding of sheet metal working and making minimum one model.
- 5) Fitting: Understanding of fitting tools and making minimum one model.
- 6) Welding: Understanding of fitting tools and making minimum one model.
- 7) Smithy: Understanding of smithy tools and making minimum one model.
- 8) Machine Tools: Demonstration of various machines like shaping and slotting machine, Milling machine, Grinding Machine, Lathe, Drilling Machine, CNC Machines, Power Tools.
Demonstration of 3D Printer.

iv) REFERENCES

- 1) Khanna, P. N., *Indian Practical Civil Engineering Handbook*, Engineers Publishers, 2012.
- 2) Punmia, B. C., Ashok, K. J. and Arun, K.J., *Surveying*, Vol. I, Laxmi Publications (P) Ltd., New Delhi, 17th Edition, 2016.
- 3) Arora, S. P. and Bindra, S. P., *Building Construction*, Dhanpat Rai Publications, 43rd Edition, 2019.
- 4) Rangwala, S. C., *Engineering Materials*, Charotar Publishing House, Anand, 43rd Edition, 2019.
- 5) Sawhney, G.S., *Mechanical Experiments and Workshop Practice*, Dream tech Press, 2019.
- 6) Varun, B., *Engineering Workshop: Civil and Mechanical Engineering Practice*, Notion Press, 1st Edition, 2020.

v) COURSE PLAN

Experiment No.	List of exercises/experiments	No. of hours
A) CIVIL WORKSHOP		
I	Set out a one room building of given plan using tape only method and using tape and cross staff.	2
II	a) Use screw gauge and vernier calliper to measure the diameter of a steel rod and thickness of a flat bar.	2
	b) Calculate the area of a built-up space and a small piece of land- Use standard measuring tape and digital distance measuring devices.	
III	a) Construct a wall using currently used building blocks such as bricks (1 ½ thick brick wall using English bond), hollow blocks, solid blocks, etc.	2



		Use spirit level to assess the tilt of walls.	
	b)	Estimate the number of different types of building blocks required to construct a wall of given dimensions.	
	c)	Transfer the level from one point to another point using a water level.	
IV		Find the level difference between any two points using dumpy level (differential levelling).	3
V	a)	Introduce the students to plumbing tools, different types of pipes, types of connections, traps, valves, fixtures and sanitary fittings.	2
	b)	Study of installation of rain water harvesting system in an educational campus.	
VI		Introduce students to the principle and working of Total Station.	2
VII		Demonstration of a simple construction work using concrete.	2
Total hours			15
B) MECHANICAL WORKSHOP			
I		Workshop practice, shop floor precautions, ethics and First Aid knowledge. Studies of mechanical tools, components and their applications: (a) Tools: Screw drivers, spanners, Allen keys, cutting pliers etc. and ories: Bearings, seals, O-rings, circlips, keys etc.	1
II		Carpentry - Understanding of carpentry tools and making minimum one model. <ul style="list-style-type: none"> • Lap joint • Cross lap joint • Dovetail joint • Mortise joints 	2
III		Foundry - Understanding of foundry tools and making minimum one model. <ul style="list-style-type: none"> • Bench Moulding • Floor Moulding • Core making • Pattern making 	2
IV		Sheet metal - Understanding of sheet metal working and making minimum one model. <ul style="list-style-type: none"> • Cylindrical shape • Conical shape • Prismatic shaped job from sheet metal 	2
V		Fitting - Understanding of fitting tools and making minimum one model. <ul style="list-style-type: none"> • Square Joint • V- Joint • Male and female fitting 	2
VI		Welding - Understanding of welding equipment's and making minimum one model. <ul style="list-style-type: none"> • Minimum any one welding practice • Making Joints using electric arc welding 	2
VII		Smithy - Understanding of smithy tools and making minimum one model. <ul style="list-style-type: none"> • Square prism • Hexagonal headed bolt • Hexagonal prism • Octagonal prism 	2
VIII		Machine tools – Demonstration of various machine tools like	2



	<ul style="list-style-type: none">• Shaping and slotting machine• Milling machine• Grinding Machine• Lathe• Drilling Machine• CNC Machines• Power Tools Demonstration of 3D Printer	
	Total hours	15

v) ASSESSMENT PATTERN**Mark distribution**

Total Marks	Continuous Internal Evaluation Marks	End Semester Evaluation Marks	End Semester Examination Duration
100	70	30	1 Hour

Continuous Internal Evaluation Pattern

Attendance	20 Marks
Class work/ Assessment /Viva-voce	50 Marks

End Semester Examination Pattern: Written Objective Examination of one hour.



SEMESTER II



Course Code	Course Name	Category	L	T	P	Credit	Year of Introduction
MA0U10B	VECTOR CALCULUS, DIFFERENTIAL EQUATIONS AND TRANSFORMS	BSC	3	1	0	4	2020

i) COURSE OVERVIEW

The objective of this course is to familiarize the prospective engineers with some advanced concepts and methods in Mathematics which include the Calculus of vector valued functions, ordinary differential equations and basic transforms such as Laplace and Fourier Transforms which are invaluable for any engineer's mathematical tool box. The topics treated in this course have applications in all branches of engineering.

ii) COURSE OUTCOMES

After the completion of the course, the student will be able to:

Course Outcomes	Description	Level
CO 1	Compute the derivatives and line integrals of vector functions and learn their applications.	Evaluate
CO 2	Evaluate surface and volume integrals and learn their inter-relations and applications.	Evaluate
CO 3	Solve linear ordinary differential equations.	Apply
CO 4	Apply Laplace transform to solve ODEs arising in engineering.	Apply
CO 5	Apply Fourier transforms of functions to solve problems arising in engineering.	Apply

iii) SYLLABUS

Vector Calculus – Derivative of vector function, Gradient, Divergence, Curl, Line integral, conservative fields, Green's theorem, surface integral, Gauss divergence theorem, Stokes' theorem.

Ordinary Differential Equations- Homogeneous and Non-Homogeneous linear differential Equations, Euler-Cauchy equations. Method of undetermined coefficients and Method of variation of parameters.

Laplace transforms: Laplace Transform and its inverse, shifting theorems, Laplace transform of derivatives and integrals, solution of differential equations using Laplace transform, Unit step function. Dirac delta function, Convolution theorem and its applications.

Fourier Transforms: Fourier integral representation, Fourier sine and cosine integrals. Fourier transform and inverse Fourier transform. Fourier sine and cosine transforms, inverse sine and cosine transform, Convolution theorem.

iv) (a) TEXT BOOKS

- 1) H. Anton, I. Biven S. Davis, *Calculus*, Wiley, 10th Edition, 2015.
- 2) Erwin Kreyszig, *Advanced Engineering Mathematics*, John Wiley & Sons, 10th Edition, 2016.



(b) REFERENCES

- 1) George F Simmons: *Differential Equation with Applications and its historical Notes*, McGraw Hill Education India, 2nd Edition, 2002.
- 2) Hemen Dutta, *Mathematical Methods for Science and Engineering*, Cengage Learning, 1st Edition, 2020.
- 3) B.S. Grewal, *Higher Engineering Mathematics*, Khanna Publishers, 44th Edition, 2018.

v) COURSE PLAN

Module	Contents	No. of hours
I	Calculus of vector functions: Vector valued function of single variable, derivative of vector function and geometrical interpretation, motion along a curve-velocity, speed and acceleration. Concept of scalar and vector fields, Gradient and its properties, directional derivative, divergence and curl, Line integrals of vector fields, work as line integral, Conservative vector fields, independence of path and potential function (results without proof).	12
II	Vector integral theorems: Green’s theorem (for simply connected domains, without proof) and applications to evaluating line integrals and finding areas. Surface integrals over surfaces of the form $z = g(x, y)$, $y = g(x, z)$ or $x = g(y, z)$, Flux integrals over surfaces of the form $z = g(x, y)$, $y = g(x, z)$ or $x = g(y, z)$, divergence theorem (without proof) and its applications to finding flux integrals, Stokes’ theorem (without proof) and its applications to finding line integrals of vector fields and work done.	12
III	Ordinary differential equations: Homogenous linear differential equation of second order, superposition principle, general solution, homogenous linear ODEs with constant coefficients-general solution. Solution of Euler-Cauchy equations (second order only). Existence and uniqueness (without proof). Non homogenous linear ODEs-general solution, solution by the method of undetermined coefficients (for the right-hand side of the form x^n , e^{kx} , $\sin ax$, $\cos ax$, $e^{kx}\sin ax$, $e^{kx}\cos ax$ and their linear combinations), methods of variation of parameters. Solution of higher order equations-homogeneous and non-homogeneous with constant coefficient using method of undetermined coefficient.	12
IV	Laplace transforms: Laplace Transform and its inverse, Existence theorem (without proof) , linearity, Laplace transform of basic functions, first shifting theorem, Laplace transform of derivatives and integrals, solution of differential equations using Laplace transform, Unit step function, Second shifting theorems. Dirac delta function and its Laplace transform, Solution of ordinary differential equation involving unit step function and Dirac delta functions. Convolution theorem (without proof) and its application to finding inverse Laplace transform of products of functions.	12
V	Fourier Transforms: Fourier integral representation, Fourier sine and cosine integrals. Fourier sine and cosine transforms, inverse sine and cosine transform. Fourier transform and inverse Fourier transform, basic properties. The Fourier transform of derivatives. Convolution theorem (without proof).	12
Total hours		60

**vi) ASSESSMENT PATTERN****Mark distribution**

Total Marks	Continuous Internal Evaluation Marks	End Semester Evaluation Marks	End Semester Examination Duration
150	50	100	3 Hours

Continuous Internal Evaluation Pattern:

Attendance	10 Marks
Continuous Assessment Tests (2 numbers)	25 Marks
Assignment/Quiz/Course project	15 Marks

End Semester Examination Pattern:

There will be two parts; Part A and Part B. Part A contain 10 questions with 2 questions from each module, having 3 marks for each question. Students should answer all questions. Part B contains 2 questions from each module of which student should answer any one. Each question can have maximum 2 sub-divisions and carry 14 marks.



Course Code	Course Name	Category	L	T	P	Credit	Year of Introduction
CY0U10A	ENGINEERING CHEMISTRY – A	BSC	3	1	0	4	2020

i) COURSE OVERVIEW

The aim of the engineering chemistry program is to expose the students to basic concepts of chemistry and its industrial as well as engineering applications. It also let the students to familiarize with different topics such as new-generation engineering materials, storage-devices, different instrumental methods etc.

ii) COURSE OUTCOMES

After the completion of the course, the student will be able to:

Course Outcomes	Description	Level
CO 1	Explain the basic concepts of electrochemistry and corrosion to explore its industrial functions in various engineering fields.	Understand
CO 2	Explain the various spectroscopic techniques like UV-Visible, IR, NMR and its applications.	Understand
CO 3	Apply the knowledge of analytical method for characterizing a chemical mixture or a compound. Understand the basic concept of SEM for surface characterisation of nanomaterials.	Apply
CO 4	Apply the knowledge of conducting polymers and advanced polymers in engineering.	Apply
CO 5	Explain various types of water treatment methods and to develop skills for treating industrial and domestic wastewater	Understand

iii) SYLLABUS

Electrochemistry – Cell prototypes, Nernst equation and its uses, different types of cells and applications of electrochemical series. Fundamentals of corrosion and its prevention.

Basics of Spectroscopy – Principles and applications of UV-Vis, IR and NMR spectroscopy, instrumentation of UV-Vis spectroscope, colorimetry, MRI technique.

Instrumental methods in chemistry and Engineering materials – TGA, DTA, and chromatography techniques; Basics of polymer chemistry, BS, ABS and Kevlar and conducting polymers, Classifications of nanomaterials, synthesis, SEM, CNT, graphene.

Stereochemistry and polymer chemistry– Different types of isomers with examples; Notations; Conformational analysis, Types of polymers, ABS, Kevlar and applications, Polyaniline and Poly pyrrole - preparation properties and applications, OLED.

Water Technology–Types of hard water and its elimination, DO, BOD and COD and its significance, disinfection of water, reverse osmosis, sewage water treatment.

iv) (a) TEXT BOOKS

- 1) D. Harvey, N. Rutledge, *Industrial Chemistry*, ETP, 1st Edition, 2018. ISBN: 9781788820554
- 2) P. W. Atkins, J de Paula, *Atkins' Physical Chemistry*, Oxford University Press, 11th Edition 2014. ISBN: 9780199697403
- 3) M. Arif, A. Fernandez, K. P. Nair, *Engineering Chemistry*, Owl Books, 1st Edition, 2015.
- 4) S. Chawla, *A text book of Engineering Chemistry*, Dhanpat Rai & Co., 2nd Edition, 2013.

**(b) REFERENCES**

- 1) C. N. Banwell, E. M. Mc Cash, *Fundamentals of Molecular Spectroscopy*, McGraw-Hill, 4th Edition, 2001. ISBN: 9780074620250
- 2) H. H. Willard, L. L. Merritt, *Instrumental Methods of Analysis*, CBS Publishers, 7th Edition, 2005. ISBN: 9788123909431
- 3) A. J. Peacock, A. Calhoun, C. Hanser, *Polymer Chemistry: Properties and Application*, Verlag GmbH & Company KG, 2012. ISBN: 9783446433434
- 4) C. Binns, *Introduction to Nanoscience and Nanotechnology*, Wiley, 2010. ISBN: 9780471776475
- 5) Roy K. Varghese, *Engineering Chemistry*, 1st Edition, Crownplus Publishers, 2019.

v) COURSE PLAN

Module	Contents	No. of hours
I	<p>Electrochemistry and corrosion: Introduction - Differences between electrolytic and electrochemical cells- Daniel cell - redox reactions - cell representation. Different types of electrodes (brief) - Reference electrodes- SHE - Calomel electrode - Glass Electrode – Construction and Working.</p> <p>Single electrode potential – definition - Helmholtz electrical double layer - Determination of E^0 using calomel electrode. Determination of pH using glass electrode. Electrochemical series and its applications. Free energy and EMF-Nernst Equation – Derivation - single electrode and cell (Numericals) –Application-Variation of EMF with temperature.</p> <p>Potentiometric titration - Introduction -Redox titration only. Lithium ion cell - construction and working.</p> <p>Conductivity- Measurement of conductivity of a solution (Numericals). Corrosion-Electro chemical corrosion – mechanism.</p> <p>Galvanic series- cathodic protection - electroless plating –Copper and Nickel plating.</p>	12
II	<p>Spectroscopic Techniques and applications: Introduction- Types of spectrum - electromagnetic spectrum - molecular energy levels - Beer Lambert's law (Numericals).</p> <p>UV-Visible Spectroscopy – Principle - Types of electronic transitions – Energy level diagram of ethane, butadiene, benzene and hexatriene. Instrumentation of UV-Visible spectrometer and applications.</p> <p>IR-Spectroscopy – Principle - Number of vibrational modes - Vibrational energy states of a diatomic molecule and -Determination of force constant of diatomic molecule (Numericals) –Applications.</p> <p>¹H NMR spectroscopy – Principle - Relation between field strength and frequency- chemical shift - spin-spin splitting (spectral problems) - coupling constant(definition) - applications of NMR- including MRI (brief).</p>	12
III	<p>Instrumental Methods and Nanomaterials: Thermal analysis – TGA- Principle, instrumentation (block diagram) and applications – TGA of CaC₂O₄.H₂O and polymers. DTA-Principle, instrumentation (block diagram) and applications - DTA of CaC₂O₄.H₂O.</p> <p>Chromatographic methods - Basic principles and applications of column and TLC- Retention factor. GC and HPLC-Principle, instrumentation (block</p>	12



	<p>diagram) - retention time and applications.</p> <p>Nanomaterials - Definition - Classification - Chemical methods of preparation -Hydrolysis and Reduction - Applications of nanomaterials – Surface characterisation -SEM – Principle and instrumentation (block diagram).</p>	
IV	<p>Stereochemistry and Polymer Chemistry: Isomerism-Structural, chain, position, functional, tautomerism and matamerism- Definition with examples - Representation of 3D structures-Newman, Sawhorse, Wedge and Fischer projection of substituted methane and ethane. Stereoisomerism - Geometrical isomerism in double bonds and cycloalkanes (cis-trans and E-Z notations). R-S Notation – Rules and examples - Optical isomerism, Chirality, Enantiomers and Diastereoisomers-Definition with examples. Conformational analysis of ethane, butane, cyclohexane, mono and di methyl substituted cyclohexane. Copolymers - Definition - Types - Random, Alternating, Block and Graft copolymers - ABS - preparation, properties and applications. Kevlar-preparation, properties and applications. Conducting polymers - Doping -Polyaniline and Polypyrrole - preparation properties and applications. OLED - Principle, construction and advantages.</p>	12
V	<p>Water Chemistry and Sewage Water Treatment: Water characteristics - Hardness - Types of hardness- Temporary and Permanent - Disadvantages of hard water -Units of hardness- ppm and mg/L - Degree of hardness (Numericals) - Estimation of hardness-EDTA method (Numerical). Water softening methods-Ion exchange process-Principle, procedure and advantages. Reverse osmosis – principle, process and advantages. Municipal water treatment (brief) - Disinfection methods - chlorination, ozone and UV irradiation. Dissolved oxygen (DO) -Estimation (only brief procedure-Winkler’s method), BOD and COD-definition, estimation (only brief procedure) and significance (Numericals). Sewage water treatment - Primary, Secondary and Tertiary - Flow diagram - Trickling filter and UASB process.</p>	12
	Total hours	60

**vi) ASSESSMENT PATTERN****Mark distribution**

Total Marks	Continuous Internal Evaluation Marks	End Semester Evaluation Marks	End Semester Examination Duration
150	50	100	3 Hours

Continuous Internal Evaluation Pattern:

Attendance	10 Marks
Continuous Assessment Tests (2 numbers)	25 Marks
Assignment/Quiz/Course project	15 Marks

End Semester Examination Pattern:

There will be two parts; Part A and Part B. Part A contain 10 questions with 2 questions from each module, having 3 marks for each question. Students should answer all questions. Part B contains 2 questions from each module of which student should answer any one. Each question can have maximum 2 sub-divisions and carry 14 marks.



Course Code	Course Name	Category	L	T	P	Credit	Year of Introduction
ES0U10B	ENGINEERING GRAPHICS	ESC	2	0	2	3	2020

i) COURSE OVERVIEW

Aim of the course is to enable the student to effectively perform technical communication through graphical representation as per global standards. The student will be able to apply the principles of projection and will be introduced to the fundamentals of Computer Aided Drawing (CAD).

ii) COURSE OUTCOMES

After the completion of the course, the student will be able to:

Course Outcomes	Description	Level
CO 1	Construct the orthographic projection of points and lines located in different quadrants.	Apply
CO 2	Prepare multiview orthographic projection of solids by visualizing them in different positions.	Apply
CO 3	Construct sectional views and develop surfaces of a given solid.	Apply
CO 4	Prepare pictorial drawings using the principles of isometric and perspective projection to visualize objects in three dimensions.	Apply
CO 5	Convert pictorial views into orthographic views.	Apply
CO 6	Prepare multiview projection and solid models of objects using CAD tools.	Apply

iii) SYLLABUS

Introduction - Relevance of technical drawing in engineering field, BIS code of practice for technical drawing.

Orthographic projection - Projection of points and lines in different quadrants, traces of line. Projection of solids in simple position, axis inclined to one reference plane and axis inclined to both reference planes.

Sections of Solids - Sections of solids cut by different section planes, true shape of the sections

Development of Surfaces - Development of surfaces of solids and solids cut by different section planes.

Isometric Projection - Isometric view and projection of solids and their combinations.

Perspective Projection - Perspective projection of solids with axis perpendicular to the ground plane.

Conversion of Pictorial Views - Conversion of pictorial views into orthographic views.

Introduction to Computer Aided Drawing - Creating 2D drawing and 3D models of various components using suitable modelling software.

**iv) (a) TEXT BOOKS**

- 1) Bhatt N.D, *Engineering Drawing*, Charotar Publishing House Pvt. Ltd, 53rd Edition, 2019.
- 2) John K.C., *Engineering Graphics*, Prentice Hall India Publishers, 1st Edition, 2009.
- 3) C. M.Agrawal, Basant Agrawal, *Engineering Graphics*, Tata McGraw-Hill, 1st Edition, 2012.

(b) REFERENCES

- 1) G. S. Phull, H. S.Sandhu, *Engineering Graphics*, John Wiley & Sons Inc Pvt. Ltd, 1st Edition, 2014.
- 2) P. I.Varghese, *Engineering Graphics*, V.I.P. Publishers, 21st Edition, 2010.
- 3) Anil Kumar K.N., *Engineering Graphics*, Adhyuth Narayan Publishers, 4th Edition, 2009.

v) COURSE PLAN

Module	Contents	No. of hours
I	Introduction: Relevance of technical drawing in engineering field. Types of lines, dimensioning, BIS code of practice for technical drawing. Orthographic projection of points and lines: Projection of points in different quadrants, projection of straight lines inclined to one plane and inclined to both planes. Trace of line, inclination of lines with reference planes, true length of line inclined to both the reference planes.	8
II	Orthographic projection of solids: Projection of simple solids such as triangular, rectangle, square, pentagonal and hexagonal prisms, pyramids, cone and cylinder. Projection of solids in simple position including profile view. Projection of solids with axis inclined to one of the reference planes and with axis inclined to both reference planes.	9
III	Sections of Solids: Sections of prisms, pyramids, cone, cylinder with axis in vertical position and cut by different section planes. True shape of the sections. Locating the section plane when the true shape of the section is given. Development of surfaces: Development of surfaces of the above solids and solids cut by different section planes. Finding the shortest distance between two points on the surface.	9
IV	Isometric projection: Isometric view and projection of prisms, pyramids, cone, cylinder, frustum of pyramid, frustum of cone, sphere, hemisphere and their combinations.	6
V	Perspective projection: Perspective projection of prisms and pyramids with axis perpendicular to the ground plane, axis perpendicular to picture plane. Conversion of pictorial view: Conversion of pictorial view into orthographic views.	5
SECTION B		



<i>(To be conducted in CAD Lab)</i>		
	Introduction to Computer Aided Drawing: Role of CAD in design and development of new products, advantages of CAD. Creating two-dimensional drawing with dimensions using suitable software. (Minimum 2 exercises mandatory) Introduction to Solid Modelling: Creating 3D models of various components using suitable modelling software. (Minimum 2 exercises mandatory)	8
	Total hours	45

vi) ASSESSMENT PATTERN**Mark distribution**

Total Marks	Continuous Internal Evaluation Marks	End Semester Evaluation Marks	End Semester Examination Duration
150	50	100	3 Hours

Continuous Internal Evaluation Pattern:

Attendance	10 Marks
Continuous Assessment Tests (2 numbers)	25 Marks Section A – 15 marks Section B – 10 marks
Assignment/Project/Case Study etc.	15 Marks Section A – 10 marks Section B – 5 marks

End Semester Examination Pattern:

ESE will be of 3hour duration on A4 size answer booklet and will be for 100 marks. The question paper shall contain two questions from each module of Section A only. Student has to answer any one question from each module. Each question carries 20 marks.



Course Code	Course Name	Category	L	T	P	Credit	Year of Introduction
ES0U10D	BASICS OF ELECTRICAL AND ELECTRONICS ENGINEERING	ESC	4	0	0	4	2020

i) COURSE OVERVIEW

This course aims to equip the students with an understanding of the fundamental principles of electrical, electronics and communication engineering.

ii) COURSE OUTCOMES

After the completion of the course, the student will be able to:

Course Outcomes	Description	Level
CO 1	Apply fundamental circuit laws and principles of electromagnetism to solve simple DC electric circuits and magnetic circuits respectively.	Apply
CO 2	Describe the fundamentals of AC generation to perform simple AC circuit analysis.	Understand
CO 3	Describe the principles of passive components, semiconductor devices and its characteristics.	Understand
CO 4	Explain the working of electronic circuits, instrumentation, radio and cellular communication systems.	Understand

iii) SYLLABUS

Basic concepts of DC circuits: Ohm's Law and Kirchoff's laws, Star-delta conversion, Analysis of DC circuits, Mesh analysis, Node analysis.

Magnetic Circuits: Basic Terminology, Simple Magnetic circuits, Electromagnetic Induction, Faraday's laws, Lenz's law, Self-inductance and mutual inductance.

Alternating Current fundamentals: Basic definitions, Average, RMS values, AC Circuits, Phasor representation, Analysis of simple AC circuits (R, L, C, RL, RC, RLC Series circuits) Three phase AC systems, Generation of three phase voltages, star and delta connections.

Introduction to Semiconductor devices: Evolution of electronics, Resistors, Capacitors, Inductors PN Junction diodes and Bipolar Junction Transistors.

Basic electronic circuits and instrumentation: DC power supply, Full wave bridge rectifier, Capacitor filter, Simple Zener voltage regulator, Amplifiers, Public Address system and Electronic Equipments.

Introduction to Communication Systems: Evolution of communication systems, Radio communication, Principle of antenna and Mobile communication.

**iv) (a) TEXT BOOKS**

- 1) William H. Hayt., Jr., Jack E. Kemmerly, Steven M. Durbin., *Engineering Circuit Analysis*, McGraw-Hill, 8th Edition, 2012.
- 2) Kothari D. P. and Nagrath I. J., *Basic Electrical Engineering*, Tata McGraw Hill, 2010.
- 3) Fitzgerald A.E., David Higginbotham E., Arvin Gabel, *Basic Electrical Engineering*, Tata McGraw Hill, 5th Edition, 2009.
- 4) Boylested, R. L. and Nashelsky, L., *Electronic Devices and Circuit Theory*, Pearson Education, 10th Edition, 2009.
- 5) Wayne Tomasi and Neil Storey, *A Textbook on Basic Communication and Information Engineering*, Pearson, 5th Edition, 2010.

(b) REFERENCES

- 1) Paul Breeze, *Power Generation Technologies*, Newnes, 3rd Edition, 2019.
- 2) Allan Hambley R., *Electrical Engineering: Principles & Applications*, Pearson Education, 7th Edition, 2018.
- 3) Mittle V. N. and Arvind Mittal, *Basic Electrical Engineering*, McGraw Hill, 2nd Edition, 2006.
- 4) N.N. Bhargava, D.C. Kulshreshtha, S.C. Gupta, *Basic Electronics and Linear Circuits*, Tata McGraw - Hill Education, New Delhi, 2nd Edition, 2014.

v) COURSE PLAN

Module	Contents	No. of hours
I	DC circuits: Review of Elementary concepts of DC circuits, Current and Voltage Division Rules, Star-delta conversion (resistive networks only-derivation not required), Numerical problems.	9
	Analysis of DC circuits: Mesh current method, Node voltage method. Solution of network equations by matrix method, Numerical problems.	
	Magnetic Circuits: Review of Magnetic Circuits, Series magnetic circuits with composite materials, Numerical problems.	
II	Electromagnetic Induction: Faraday's laws, Lenz's law, statically induced and dynamically induced emfs, Self-inductance and mutual inductance, coefficient of coupling (derivation not required), Numerical Problems.	9
	Alternating Current fundamentals: Generation of alternating voltages, Basic definitions, Average and RMS values of sinusoidal waveforms, Numerical Problems.	
	Power Generating Stations: Solar, Wind, Hydro-electric and Nuclear power stations, Basic concepts with block diagrams only.	



III	<p>Analysis of AC Circuits: Transient Analysis of RL circuit, Steady state Analysis of RL circuit, Phasor representation of sinusoidal quantities, Complex forms.</p> <p>Analysis of simple AC circuits: Purely resistive, inductive and capacitive circuits; Analysis of RL, RC and RLC series circuits, active, reactive and apparent power. Illustrations using simple example.</p>	12
	<p>Three phase AC systems: Generation of three phase voltages, advantages of three phase systems, star and delta connections (balanced only), relation between line and phase voltages, line and phase currents, Power in three phase circuit, Numerical problems.</p>	
IV	Introduction to Semiconductor devices	
	<p>Evolution of electronics – Vacuum tubes to nano electronics (In evolutionary perspective only)</p>	1
	<p>Resistors, Capacitors and Inductors: types, specifications, standard values, colour coding (No constructional features)</p>	2
	<p>PN Junction diode: Principle of operation, V-I characteristics, principle of avalanche breakdown and Zener breakdown</p>	2
	<p>Bipolar Junction Transistors: PNP and NPN structures, principle of operation, relation between current gains in CE, CB and CC Configurations, input and output characteristics of common emitter configuration.</p>	5
V	Basic electronic circuits and instrumentation	
	<p>Rectifiers and Power supplies: Block diagram description of a dc power supply, working of a full wave bridge rectifier, capacitor filter (no analysis), working of simple Zener voltage regulator</p>	3
	<p>Amplifiers: Concept of voltage divider biasing, circuit diagram and working of common emitter (RC coupled) amplifier with its frequency response, block diagram of Public Address system.</p>	5
	<p>Electronic Instrumentation: Block diagram of an electronic instrumentation system, functions of various equipments (multimeter, DSO and function generator)</p>	2
VI	Introduction to Communication Systems	
	<p>Evolution of communication systems: Telegraphy to 5G</p>	1
	<p>Radio communication: Principle of AM & FM, frequency bands used for various communication systems, block diagram of super heterodyne receiver.</p> <p>Principle of antenna: Radiation from accelerated charge</p>	5
	<p>Mobile communication: Basic principles of cellular communications, principle and block diagram of GSM.</p>	4
	Total hours	60

**vi) ASSESSMENT PATTERN****Mark distribution**

Total Marks	Continuous Internal Evaluation Marks	End Semester Evaluation Marks	End Semester Examination Duration
150	50	100	3 Hours

Continuous Internal Evaluation Pattern:

Attendance	10 Marks
Continuous Assessment Tests (2 numbers)	25 Marks
Assignment/Quiz/Course project	15 Marks

End Semester Examination Pattern:

There will be two parts; Part I – Basic Civil Engineering and Part II – Basic Mechanical Engineering. Part I and PART II carries 50 marks each. For the end semester examination, part I contain 2 parts - Part A and Part B. Part A contain 5 questions carrying 4 marks each (not exceeding 2 questions from each module). Part B contains 2 questions from each module out of which one to be answered. Each question carries 10 mark and can have maximum 2 sub-divisions. The pattern for end semester examination for part II is same as that of part I. However, student should answer both part I and part 2 in separate answer booklets.



Course Code	Course Name	Category	L	T	P	Credit	Year of Introduction
HSOU10B	PROFESSIONAL COMMUNICATION	HSC	2	0	2	--	2020

i) COURSE OVERVIEW

The objective of this course is to equip students with the necessary skills to listen, read, write, and speak so as to comprehend and successfully convey any idea, technical or otherwise, as well as give them the necessary polish to become persuasive communicators. The course aims to enhance the employability and career Skills of students and orient the students towards grooming as a professional.

ii) COURSE OUTCOMES

After the completion of the course, the student will be able to:

Course Outcomes	Description	Level
CO 1	Develop effective language skills relevant to Engineering as a profession and demonstrate these through writing and making presentations.	Create
CO 2	Analyze, interpret and effectively summarize a variety of textual and audio content for specific needs	Analyse
CO 3	Apply appropriate thinking and problem solving techniques to solve new case studies.	Apply
CO 4	Present and analyse a given technical/non-technical topic in a group setting and arrive at generalizations/consensus.	Analyse
CO 5	Create professional and technical documents that are clear and adhering to all thenecessary conventions.	Create
CO 6	Manage and apply interviewing skills.	Apply

iii) SYLLABUS

Communication Skills: Introducing yourself and others professionally, elevator pitch, recommendation letter, e-mails, netiquettes, telephone etiquettes, demi-official letters.

Business Communication and Technical writing: Product description, narrating an incident, report writing, agenda and minutes, memo, Asking for information and giving information, explaining processes and products, giving instructions, planning a course of action.

Creative Thinking, Critical Thinking Skills and problem solving: Expressing opinion, GD, Arguing, Reading critical texts (general and academic) and summarizing, listening and responding, Negotiation strategies and decision making skills.

Presentation Skills: Oral Presentation Skills (Proposal presentation), Power point presentation (Projects).

Interviews: CVs and Resumes, Job application, Types of interviews, successful interviews, interview etiquette, dress code, body language, telephone/online (Skype) interviews, one-to-one interview & panel interview, FAQs related to job interviews.

**iv) (a) TEXT BOOKS**

- 1) Meenakshi Raman and Sangeetha Sharma (2018). *Professional Communication*, Oxford University Press, 3rd Edition, 2018.
- 2) Meenakshi Raman and Sangeetha Sharma, *Technical Communication: Principles and Practice*, Oxford University Press, 2nd Edition, 2011.
- 3) Ashraf Rizvi M., *Effective Technical Communication*. New Delhi: Tata McGraw Hill Publications, 2007.

(b) REFERENCES

- 1) *English for Engineers and Technologists* (Combined edition, Vol. 1 and 2, Orient Blackswan, 2010.
- 2) Stephen E. Lucas, *The Art of Public Speaking*, 10th Edition; McGraw Hill Education, 2012.
- 3) William Strunk Jr. & E.B. White, *The Elements of Style*, 4th Edition, Pearson, 1999.
- 4) David F. Beer and David, *Guide to writing as an Engineer*, John Willey. New York, 2004.
- 5) Goodheart-Willcox, *Professional Communication*, 1st Edition, 2017.
- 6) *Training in Interpersonal Skills: Tips for Managing People at Work*, Pearson Education, India, 6th Edition, 2015.
- 7) *The Ace of Soft Skills: Attitude, Communication and Etiquette for Success*, Pearson Education; 1st Edition, 2013.
- 8) Anand Ganguly, *Success in Interview*, RPH, 5th Edition, 2016.
- 9) Raman Sharma, *Technical Communications*, Oxford Publication, London, 2004.

v) COURSE PLAN

Module	Contents	No. of hours
I	<p>Use of language in communication: Significance of technical communication Vocabulary Development: technical vocabulary, vocabulary used in formal letters/emails and reports, sequence words, misspelled words, compound words, finding suitable synonyms, paraphrasing, verbal analogies. Language Development: subject-verb agreement, personal passive voice, numerical adjectives, embedded sentences, clauses, conditionals, reported speech, active/passive voice.</p> <p>Technology-based communication: Effective email messages, slide presentations, editing skills using software. Modern day research and study skills: search engines, repositories, forums such as GitHub, Stack Exchange, OSS communities (MOOC, SWAYAM, NPTEL), and Quora; Plagiarism</p>	6
II	<p>Reading, Comprehension, and Summarizing: Reading styles, speed, valuation, critical reading, reading and comprehending shorter and longer technical articles from journals, newspapers, identifying the various transitions in a text, SQ3R method, PQRST method, speed reading.</p>	6



	Comprehension: techniques, understanding textbooks, marking and underlining, Note-taking: recognizing non-verbal cues.	
III	<p>Oral Presentation: Voice modulation, tone, describing a process, Presentation Skills: Oral presentation and public speaking skills, business presentations, Preparation: organizing the material, self-introduction, introducing the topic, answering questions, individual presentation practice, presenting visuals effectively.</p> <p>Debate and Group Discussions: introduction to Group Discussion (GD), differences between GD and debate; participating GD, understanding GD, brainstorming the topic, questioning and clarifying, GD strategies, activities to improve GD skills.</p>	6
IV	<p>Listening and Interview Skills Listening: Active and Passive listening, listening: for general content, to fill up information, intensive listening, for specific information, to answer, and to understand.</p> <p>Developing effective listening skills, barriers to effective listening, listening to longer technical talks, listening to classroom lectures, talks on engineering /technology, listening to documentaries and making notes, TED talks.</p> <p>Interview Skills: types of interviews, successful interviews, interview etiquette, dress code, body language, telephone/online (skype) interviews, one-to-one interview & panel interview, FAQs related to job interviews</p>	6
V	<p>Formal writing: Technical Writing: differences between technical and literary style. Letter Writing (formal, informal and semi formal), Job applications, Minute preparation, CV preparation (differences between Bio-Data, CV and Resume), and Reports. Elements of style, Common Errors in Writing: describing a process, use of sequence words, Statements of Purpose, Instructions, Checklists.</p> <p>Analytical and issue-based Essays and Report Writing: basics of report writing; Referencing Style (IEEE Format), structure of a report; types of reports, references, bibliography</p>	6
	Total Hours	30

LAB ACTIVITIES

- **Written:** Letter writing, CV writing, LinkedIn profile, Attending a meeting and Minutes Preparation, Vocabulary Building
- **Spoken:** Phonetics, MMFS (Multimedia Feedback System), Mirroring, Elevator Pitch, telephone etiquette, qualities of a good presentation with emphasis on body language and use of visual aids.
- **Listening:** Exercises based on audio materials like TED talks, radio and podcasts. .
- **Reading:** Speed Reading, Reading with the help of Audio Visual Aids, Reading Comprehension Skills
- **Mock interview and Debate/Group Discussion:** concepts, types, Do's and don'ts - intensive practice

**vi) ASSESSMENT PATTERN****Mark distribution**

Total Marks	Continuous Internal Evaluation Marks	End Semester Evaluation Marks	End Semester Examination Duration
100	50	50	2 Hours

Continuous Internal Evaluation Pattern:

Attendance	10 Marks
Class work/ Assessment /Viva-voce	25 Marks
Continuous Assessment Marks	15 Marks



Course Code	Course Name	Category	L	T	P	Credit	Year of Introduction
ES0U10E	PROGRAMMING IN C	ESC	2	1	2	4	2020

i) COURSE OVERVIEW

This course aims to introduce the concepts of structured programming. It covers basic concepts of C programming language including arrays, functions, pointers and files. This course involves a lab component which equips the learner to solve computational problems through programming.

ii) COURSE OUTCOMES

After the completion of the course, the student will be able to:

Course Outcomes	Description	Level
CO 1	Explain the fundamentals of computer architecture and types of software.	Understand
CO 2	Develop a solution using algorithm /flowchart to a computational problem.	Apply
CO 3	Construct programs with control statements and arrays.	Apply
CO4	Make use of user defined data types or functions to solve computational problems.	Apply
CO5	Develop programs using files and pointers.	Apply

iii) SYLLABUS

Computer architecture & Programming Languages – Basics of Computer architecture, Types of Programming Languages, System Software, Application Software, Introduction to structured programming, Algorithms, Flowcharts and Pseudo-codes

C Programming Language – Data Types, variables, keywords, Constants, Operators and Expressions, Control Flow Statements- Conditional statements, Iterative statements, programs

Arrays and Strings– Multidimensional arrays and matrices, String processing, searching and sorting in 1D array.

Functions – Scope of variable, Pass by reference and value methods, Recursive functions. Structures and union, Storage Classes

Pointers and Files- File Operations, Sequential access and random access, programs covering pointers and files, Introduction to data structures – Types of data structure, Singly linked list.

iv) (a) TEXT BOOKS

- 1) Byron Gottfried, *Programming with C* (Schaum's Outlines Series), Mcgraw Hill Education, 3rd Edition, 2017.
- 2) H. M. Deitel, P. J. Deitel, *C: How to program*, 7th Edition, Pearson Education, 2010.
- 3) Anita Goel, *Computer Fundamentals*, Pearson, 1st Edition, 2010.
- 4) Ellis Horowitz, Sartaj Sahini, Susan Anderson Freed, *Fundamentals of Data Structures in C*, 2nd Edition, 2008.

(b) REFERENCES

- 1) Brian W. Kernighan and Dennis M. Ritchie, *C Programming Language*, Pearson, 2nd Edition, 2015.
- 2) Rajaraman V, PHI, *Computer Basics and Programming in C*, 1st Edition, 2007.
- 3) Anita Goel and Ajay Mittal, *Computer fundamentals and Programming in C*, 1st Edition, 2013.

**v) COURSE PLAN**

Module	Contents	No. of hours
I	Basics of Computer architecture.-Von-Neumann Architecture- Processor, Memory, Input and Output devices. Types of Programming Languages, System Software, Application Software: Compilers, Interpreters, high level and low level languages Introduction to structured programming, Algorithm, flowcharts and Pseudo-code –Examples	8
II	Basic structure of C program: Character set, Tokens, Identifiers in C, Variables and Data Types, Constants, Console IO Operations, printf and scanf, Operators and Expressions: Expressions and Arithmetic Operators, Relational and Logical Operators, Conditional operator, size of operator, Assignment operators and Bitwise Operators. Operators Precedence. Control Flow Statements: If Statement, Switch Statement, Unconditional Branching using goto statement, While Loop, Do While Loop, For Loop, Break and Continue statements.	9
III	Arrays. Strings-string handling functions. Multidimensional arrays and matrices. Linear search and Bubble Sort in array. String processing: In built string handling functions Simple programs covering arrays and strings	9
IV	Functions : The prototype declaration, Function definition. Function call: Passing arguments to a function, by value, by reference. Scope of variable names. Recursive function calls. Storage Classes. Structure and union in C, Array of structures	8
V	Pointers: Pointer variables. Declaring and dereferencing pointer variables.. Accessing arrays through pointers. File Operations: open, close, read, write, append Sequential access and random access to files: In built file handling functions (rewind(), fseek(), ftell(), feof(), fread(), fwrite()), simple programs covering pointers and files. Introduction to Data Structures: Linear and Non-linear data structures, Singly Linked list and its operations.	11
	Total hours	45

C PROGRAMMING LAB (Practical Part of ES0U10E)-Total hours 15

1. Familiarization of console I/O and operators in C
 - i) Display “Hello World”
 - ii) Read two numbers, add them and display their sum
 - iii) Read the radius of a circle, calculate its area and display it
 - iv) Area of triangle after reading its sides
2. Read 3 integer values and find largest of three numbers.
3. Check whether given year is leap year.
4. Display the grade of a student after reading his mark for a subject. (Use switch)
5. Read a Natural Number and check whether the number is prime or not
6. Read a Natural Number and check whether the number is Armstrong or not
7. Display second largest number after reading n numbers from user. (Without array).
8. Read n integers, store them in an array and find their sum and average
9. Read n integers, store them in an array and search for an element in the array using an algorithm for Linear Search
10. Read n integers, store them in an array and sort the elements in the array using Bubble Sort algorithm



11. Write a menu driven program for performing matrix addition, multiplication and finding the transpose. Use functions to (i) read a matrix, (ii) find the sum of two matrices, (iii) find the product of two matrices, (i) find the transpose of a matrix and (v) display a matrix.
 12. Display sum of diagonal elements of a matrix
 13. Read a string (word), store it in an array and check whether it is a palindrome word or not.
 14. Read a string (ending with a \$ symbol), store it in an array and count the number of vowels, consonants and spaces in it.
 15. Display first n prime numbers using Function.
 16. Program to find the sum of digits of a number using recursion
 17. Using structure, read and print data of n employees(Name, Employee Id and Salary)
 18. Read the marks of three subjects for n students of a class and display their names in the order of rank. (Use array of structure)
 19. Input and Print the sum of elements of an array using pointers
 20. Create a file and perform the following
 - i) Write data to the file
 - ii) Read the data in a given file & display the file content on console
 - iii) append new data and display on console
 21. Open a text input file and count number of characters, words and lines in it; and store the results in an output file.
 22. Implementation of Singly Linked List.
- vi) **ASSESSMENT PATTERN**

Mark distribution

Total Marks	Continuous Internal Evaluation Marks	End Semester Evaluation Marks	End Semester Examination Duration
150	50	100	3 Hours

Continuous Internal Evaluation Pattern:

Attendance	10 Marks
Continuous Assessment Test 1 (For theory – 2 hours)	20 Marks
Continuous Assessment Test 2 (For lab, internal examination – 2 hours)	20 Marks

Internal Examination Pattern: There will be two parts; Part A and Part B. Part A contains 5 questions with 2 questions from each module (2.5 modules x 2 = 5), having 3 marks for each question. Students should answer all questions. Part B also contains 5 questions with 2 questions from each module (2.5 modules x 2 = 5), of which a student should answer any one. The questions should not have subdivisions and each one carries 7 marks.

End Semester Examination Pattern: There will be two parts; Part A and Part B. Part A contains 10 questions with 2 questions from each module, having 3 marks for each question. Students should answer all questions. Part B contains 2 questions from each module of which a student should answer any one. Each question can have maximum 2 sub-divisions and carry 14 marks



Course Code	Course Name	Category	L	T	P	Credit	Year of Introduction
CY0U18A	ENGINEERING CHEMISTRY LAB	BSC	0	0	2	1	2020

i) COURSE OVERVIEW

This course is designed to familiarize with the basic experiments in industrial chemistry and to accustom the students with the handling and analysing chemicals and standard laboratory equipments.

ii) COURSE OUTCOMES

After the completion of the course, the student will be able to:

Course Outcomes	Description	Level
CO 1	Apply different techniques of quantitative chemical analysis to generate basic experimental skills.	Apply
CO 2	Explain the use of spectroscopic techniques for analysing and interpreting the IR spectra and NMR spectra of some organic compounds.	Understand
CO 3	Use instrumental techniques for chemical analysis.	Apply
CO 4	Organize scientific experiments as a team and analyse the results of such experiments.	Evaluate
CO 5	Create an experiment by themselves and applying them to real world problems and data.	Create

iii) SYLLABUS

1. Estimation of total hardness of water by EDTA method.
2. Analysis of IR and ¹H NMR spectra of organic compounds.
3. Determination of wavelength of absorption maximum and colorimetric estimation of Fe³⁺ in solution.
4. Determination of molar absorptivity of a compound.
5. Estimation of chloride in water by argentometric method.
6. Calibration of pH meter and determination of pH of a solution.
7. Potentiometric titration: Acid – base titration.
8. Estimation of dissolved oxygen in water by Winkler's method.

iv) REFERENCES

- 1) Mohapatra R. K., *Engineering Chemistry with Laboratory Experiments*, PHI Learning, New Delhi, 1st Edition, 2015.
- 2) George S. C., Jose R., *Lab Manual of Engineering Chemistry*, S. Chand & Company Pvt Ltd, New Delhi, 1st Edition, 2019.
- 3) Slowinski E., Wolsey W. C., *Chemical Principles in the Laboratory*, Cengage Learning, New Delhi, 11th Edition, 2008.

**v) ASSESSMENT PATTERN****Mark distribution**

Total Marks	Continuous Internal Evaluation Marks	End Semester Evaluation Marks	End Semester Examination Duration
100	70	30	1 Hour

Continuous Internal Evaluation Pattern

Attendance	20 Marks
Class work/ Assessment /Viva-voce	50 Marks

End Semester Examination Pattern: Written Objective Examination of one hour.



Course Code	Course Name	Category	L	T	P	Credit	Year of Introduction
ES0U18B	ELECTRICAL AND ELECTRONICS WORKSHOP	ESC	0	0	2	1	2020

i) COURSE OVERVIEW:

To expose the students to the commonly used accessories and components in electrical installations and to provide hands on experience of wiring of electrical circuits.

To enable the students to familiarize, identify, construct, and debug the electronic components, devices and circuits. It also enables the students engineering skills by soldering practices of electronic circuits.

ii) COURSE OUTCOMES

After the completion of the course, the student will be able to:

Course Outcomes	Description	Level
CO 1	Identify electrical accessories, protective elements and their standard symbols and the tools used for electrical wiring.	Remember
CO 2	Develop the connection diagram, identify the suitable accessories and materials necessary for wiring simple lighting circuits for domestic buildings.	Apply
CO 3	Identify different types of batteries and different types of earthing.	Remember
CO 4	Explain the working and purpose of fuse, MCB, ELCB etc. and solar powered circuit.	Understand
CO 5	Test various electronic components.	Understand
CO 6	Draw circuit schematics with EDA tools.	Apply
CO 7	Implement basic electronic circuits on general purpose PCB	Apply

iii) SYLLABUS

Familiarization/Identification of electrical accessories and protective elements, wiring of circuits using PVC conduits, wiring of simple solar chargeable circuit and determination of its characteristics, Demonstration of power distribution arrangement and earthing schemes, Identification of different types of batteries.

Familiarization of electronic components, drawing of electronic circuit diagrams, Familiarization of testing instruments, testing of electronic components, Inter-connection methods, soldering practice, Printed circuit boards, Assembling of electronic circuits in PCB.

iv) REFERENCES

- 1) Singh R. P., *Electrical Workshop: Safety, Commissioning, Maintenance & Testing of Electrical Equipment*, Dream tech Press, 3rd Edition, 2019.
- 2) John H. Watt, *Terrell Croft American Electricians' Handbook: A Reference Book for the Practical Electrical Manual*, McGraw-Hill, 9th Edition, 2002.
- 3) NavasK A, *Electronics Lab Manual*, , Volume 1, PHI Learning Private Limited, 5th



Edition, 2015.

v) COURSE PLAN

Experiment No.	PART I ELECTRICAL WORKSHOP List of exercises/experiments	No. of hours
1	Familiarization/Identification of electrical components with specification (Functionality, type, size, colour coding, symbol, cost etc. of Wires, Cables, Connectors, Fuses, MCB, ELCB, Switches and other electrical installation equipments with ratings).	2
2	Wiring of one lamp controlled by one SPST switch and a plug socket (PVC conduit wiring).	2
3	Wiring of light/fan circuit controlled by two SPDT switches (Staircase wiring).	2
4	Wiring of a light circuit and a power circuit for domestic applications.	2
5	Wiring of simple solar chargeable circuit and determination of its characteristics.	2
6	Demonstration of power distribution arrangement using single phase MCB distribution board with ELCB, main switch and Energy meter.	2
7	Understand the safety precautions to be observed in the workshop and learn about safety procedures of first aid in case of electrical hazards.	2
8	Video demonstration of Pipe and Plate Earthing Schemes.	1
Total hours		15
Experiment No.	PART II ELECTRONICS WORKSHOP List of Exercises / Experiments	No. of hours
1	Familiarization/Identification of electronic components with specification (Functionality, type, size, colour coding, package, symbol, cost etc. (Active, Passive, Electrical, Electronic, Electro-mechanical, Wires, Cables, Connectors, Fuses, Switches, Relays, Crystals, Displays, Fasteners, Heat sink etc.))	2
2	Drawing of electronic circuit diagrams using standard symbols and introduction to EDA tools, Interpret data sheets of discrete components and IC's, Estimation and costing.	2
3	Familiarization/Application of testing instruments and commonly used tools. [Multimeter, Function generator, Power supply, DSO etc.] [Soldering iron, Desoldering pump, Pliers, Cutters, Wire strippers, Screw drivers, Tweezers, Crimping tool, Hot air soldering and desoldering station etc.]	2
4	Testing of electronic components [Resistor, Capacitor, Diode, Transistor and JFET using multimeter]	2
5	Inter-connection methods and soldering practice. [Bread board, Wrapping, Crimping, Soldering - types - selection of materials and safety precautions, soldering practice in connectors and general-purpose PCB, Crimping.]	2
6	Printed circuit boards (PCB) [Types, Single sided, Double sided, PTH, Processing methods, Design (using Proteus) and fabrication of a single sided PCB for a simple circuit with manual etching (Ferric chloride) and drilling.]	2
7	Assembling of electronic circuit/system on general purpose PCB, test	3



	and show the functioning 1. Fixed voltage power supply with transformer, rectifier diode, capacitor filter, Zener/IC regulator 2. Square wave generation using IC 555 timer in IC base.	
	Total hours	15

vi) ASSESSMENT PATTERN**Mark distribution**

Total Marks	Continuous Internal Evaluation Marks	End Semester Evaluation Marks	End Semester Examination Duration
100	70	30	1 Hour

Continuous Internal Evaluation Pattern

Attendance	20 Marks
Class work/ Assessment /Viva-voce	50 Marks

End Semester Examination Pattern: Written Objective Examination of one hour.



SEMESTER III



Course Code	Course Name	Category	L	T	P	Credit	Year of Introduction
MA0U20A	PARTIAL DIFFERENTIAL EQUATIONS AND COMPLEX ANALYSIS	BSC	3	1	0	4	2020

i) COURSE OVERVIEW

This course introduces basic ideas of partial differential equations which are widely used in the modelling and analysis of a wide range of physical phenomena and has got application across all branches of engineering. The basic theory of functions of a complex variable, residue integration and conformal transformation are discussed.

ii) COURSE OUTCOMES

After the completion of the course, the student will be able to:

Course Outcomes	Description	Level
CO 1	Solve partial differential equations.	Apply
CO 2	Use appropriate methods to solve one dimensional wave equation and heat equation.	Apply
CO 3	To solve problems using analyticity of complex functions	Apply
CO 4	Find the image of regions under conformal mapping	Apply
CO 5	Find complex integrals using Cauchy's formulas to compute several kinds of integrals.	Apply
CO 6	Find the series expansion of complex functions	Apply

iii) SYLLABUS

Partial differential equations: Formation of partial differential equations, Solutions of a partial differential equations, Linear equations of the first order, Method of separation of variables.

One dimensional wave equation-derivation and solution -One dimensional heat equation, derivation and solution

Complex Differentiation: Analytic functions, Cauchy-Riemann equations, harmonic functions, Conformal mappings- standard mappings, Linear fractional transformation .

Complex integration: Line integrals in the complex plane, Contour integrals, Cauchy integral theorem, Cauchy Integral formula

Taylor's series and Laurent's series, zeros of analytic functions, singularities, Residues, Cauchy Residue theorem, Evaluation of definite integral using residue theorem.

**iv) (a) TEXT BOOKS**

- 1) B.S. Grewal, *Higher Engineering Mathematics*, Khanna Publishers, 44th Edition, 2018.
- 2) Erwin Kreyszig, *Advanced Engineering Mathematics*, 10th Edition, John Wiley & Sons, 2016.

(a) REFERENCES

- 1) J. Stewart, *Essential Calculus*, Cengage, 2nd Edition, 2017
- 2) G.B. Thomas and R.L. Finney, *Calculus and Analytic geometry*, 9th Edition, Pearson, Reprint, 2002.
- 3) Peter V. O'Neil, *Advanced Engineering Mathematics*, Cengage, 7th Edition, 2012.

v) COURSE PLAN

Module	Contents	No. of hours
I	Partial differential equations, Formation of partial differential equations –elimination of arbitrary constants-elimination of arbitrary functions, Solutions of a partial differential equations, Equations solvable by direct integration, Linear equations of the first order- Lagrange's linear equation, Non-linear equations of the first order - Charpit's method Boundary value problems, Method of separation of variables.	12
II	One dimensional wave equation- vibrations of a stretched string, Derivation. Solution of wave equation using method of separation of variables, Fourier series solution of boundary value problems involving wave equation, D'Alembert's solution of the wave equation. One dimensional heat equation, derivation. Solution of the heat equation, using method of separation of variables, Fourier series solutions of boundary value problems involving heat equation.	13
III	Complex function, limit, continuity, derivative, analytic functions, Cauchy-Riemann equations-harmonic functions, finding harmonic conjugate-Conformal mappings- mappings of $w = z^2, w = e^z, w = \frac{1}{z}, w = \sin z$	12
IV	Complex integration, Line integrals in the complex plane, Basic properties, first evaluation method, second evaluation method, use of representation of a path-Contour integrals. Cauchy integral theorem (without proof) on simply connected domain, on multiply connected domain (without proof). Cauchy Integral formula (without proof). Cauchy Integral formula for derivatives of an analytic function Taylor's series and Maclaurin series.	11



V	Laurent's series (without proof)-zeros of analytic functions, singularities, poles, removable-singularities, essential singularities, Residues, Cauchy Residue theorem (without proof), Evaluation of definite integral using residue theorem-Residue integration of real integrals –integrals of rational functions of $\cos\theta$ and $\sin\theta$, integrals of improper integrals of the form $\int_{-\infty}^{\infty} f(x) dx$ with no poles on the real axis. ($\int_A^B f(x) dx$ whose integrand become infinite at a point in the interval of integration is excluded from the syllabus)	12
	Total hours	60

vi) ASSESSMENT PATTERN**Mark distribution**

Total Marks	Continuous Internal Evaluation Marks	End Semester Evaluation Marks	End Semester Examination Duration
150	50	100	3 Hours

Continuous Internal Evaluation Pattern:

Attendance	10 Marks
Continuous Assessment Tests (2 numbers)	25 Marks
Assignment/Quiz/Course project	15 Marks

End Semester Examination Pattern:

There will be two parts; Part A and Part B. Part A contain 10 questions with 2 questions from each module, having 3 marks for each question. Students should answer all questions. Part B contains 2 questions from each module of which student should answer any one. Each question can have maximum 2 sub-divisions and carry 14 marks.



Course Code	Course Name	Category	L	T	P	Credit	Year of Introduction
EC1U20A	SOLID STATE DEVICES	PCC	3	1	0	4	2020

i) **PREREQUISITE:** ES0U10D Basics of Electrical and Electronics Engineering

ii) **COURSE OVERVIEW**

Goal of this course is to provide an insight into the basic semiconductor concepts. It also provide a sound understanding of current semiconductor devices and technology to appreciate its applications to electronics circuits and system

iii) **COURSE OUTCOMES**

After the completion of the course, the student will be able to:

Course Outcomes	Description	Level
CO 1	Describe the concepts of equilibrium carrier concentration and excess carriers in Semiconductors.	Understand
CO 2	Explain the carrier transport mechanisms in semiconductors.	Understand
CO 3	Illustrate the operation and characteristics of PN junction diode and bipolar junction transistors.	Apply
CO 4	Illustrate the principle of operation and characteristics of MOS devices.	Apply
CO 5	Discuss about scaling and short channel effects in MOSFETs.	Understand

iv) **SYLLABUS**

Semiconductor classification, Fermi Dirac distribution, Fermi level, Energy band diagram, Density of states, Equilibrium concentration of electrons and holes, Excess carriers in semiconductors, quasi Fermi levels.

Carrier transport in semiconductors, Hall Effect, Diffusion, Einstein relations, Poisson equations, Continuity equations, Current flow equations.

PN junctions- Potential and Charge distribution at the junction, Biasing and Energy band diagrams, Ideal diode equation, Metal Semiconductor contacts, Ohmic and Rectifying Contacts, Bipolar junction transistor, current components, Base width modulation.

Ideal MOS capacitor, band diagrams, threshold voltage, body effect, MOSFET-structure, types, Drain current equation.

MOSFET scaling – constant voltage scaling and constant field scaling. Sub threshold conduction in MOS, Short channel effects, FinFET –Structure, operation, and advantages.

**v) a) TEXT BOOKS**

- 1) Ben G. Streetman and Sanjay Kumar Banerjee, *Solid State Electronic Devices*, Pearson 6/e, 2010
- 2) Sung Mo Kang, *CMOS Digital Integrated Circuits: Analysis and Design*, McGraw-Hill, Third Ed., 2016
- 3) Neamen, *Semiconductor Physics and Devices*, McGraw Hill, 4/e, 2012

b) REFERENCES

- 1) Pierret, *Semiconductor Devices Fundamentals*, Pearson, 2006
- 2) Sze S.M., *Physics of Semiconductor Devices*, John Wiley, 3/e, 2005
- 3) Achuthan, K N Bhat, *Fundamentals of Semiconductor Devices*, 1e, McGraw Hill, 2015\
- 4) Jan M.Rabaey, Anantha Chandrakasan, Borivoje Nikolic, *Digital Integrated Circuits – A Design Perspective*, PHI.

vi) COURSE PLAN

Module	Contents	No. of hours
I	Elemental and compound semiconductors, Intrinsic and Extrinsic semiconductors, concept of effective mass, Fermions-Fermi Dirac distribution, Fermi level, Doping; Energy band diagram, Equilibrium and steady state conditions, Density of states, Effective density of states, Equilibrium concentration of electrons and holes. Excess carriers in semiconductors: Generation and recombination mechanisms of excess carriers, quasi Fermi levels.	13
II	Carrier transport in semiconductors, drift, conductivity and mobility, variation of mobility with temperature and doping, Hall Effect. Diffusion, Einstein relations, Poisson equations, Continuity equations, Current flow equations, Diffusion length, Gradient of quasi Fermi level.	13
III	PN junctions: Contact potential, Electrical Field, Potential and Charge distribution at the junction, Biasing and Energy band diagrams, Ideal diode equation. Metal Semiconductor contacts, Electron affinity and work function, Ohmic and Rectifying Contacts, current voltage characteristics. Bipolar junction transistor, current components, Transistor action, Base width modulation.	13
IV	Ideal MOS capacitor, band diagrams at equilibrium, accumulation, depletion and inversion, threshold voltage, body effect. MOSFET-structure, types, Drain current equation (derive)- linear and saturation region, Drain characteristics, transfer characteristics.	11
V	MOSFET scaling – need for scaling, constant voltage scaling and constant field scaling. Sub threshold conduction in MOS, Short channel effects- Channel length modulation, Drain Induced Barrier Lowering, Velocity	10



	Saturation, Threshold Voltage Variations and Hot Carrier Effects. Non-Planar MOSFETs: Fin FET –Structure, operation and advantages	
	Total hours	60

vii) ASSESSMENT PATTERN**Mark distribution**

Total Marks	Continuous Internal Evaluation Marks	End Semester Evaluation Marks	End Semester Examination Duration
150	50	100	3 Hours

Continuous Internal Evaluation Pattern:

Attendance	10 Marks
Continuous Assessment Tests (2 numbers)	25 Marks
Assignment/Quiz/Course project	15 Marks

End Semester Examination Pattern:

There will be two parts; Part A and Part B. Part A contain 10 questions with 2 questions from each module, having 3 marks for each question. Students should answer all questions. Part B contains 2 questions from each module of which student should answer any one. Each question can have maximum 2 sub-divisions and carry 14 marks.



Course Code	Course Name	Category	L	T	P	Credit	Year of Introduction
EC1U20B	LOGIC CIRCUIT DESIGN	PCC	3	1	0	4	2020

i) **PREREQUISITE:**ES0U10D Basics of Electrical and Electronics Engineering

ii) COURSE OVERVIEW

The course aims at providing an idea about the digital circuits and the design of different functions effectively using basic building blocks.

iii) COURSE OUTCOMES

After the completion of the course, the student will be able to:

Course Outcomes	Description	Level
CO 1	Explain the positional number systems and its arithmetic operations.	Understand
CO 2	Design combinational circuits using logic gates.	Apply
CO 3	Design the sequential circuits using the basic building blocks like flip-flops.	Apply
CO 4	Develop combinational and sequential logic circuits using hardware description language (HDL).	Apply
CO 5	Explain the different types of logic families with respect to performance and efficiency.	Understand

iv) SYLLABUS

Number Systems and Codes - Binary and hexadecimal number systems; Methods of base conversions; Binary and hexadecimal arithmetic; Representation of signed numbers; Fixed and floating point numbers; Binary coded decimal codes; Gray codes; Excess 3 code. Alphanumeric codes: ASCII. Basics of verilog -- basic language elements: identifiers, data objects, scalar data types, operators.

Boolean Postulates and Fundamental Gates - Boolean postulates and laws – Logic Functions and Gates De-Morgan's Theorems, Principle of Duality, Minimization of Boolean expressions, Sum of Products (SOP), Product of Sums (POS), Canonical forms, Karnaugh map Minimization. Modeling in verilog, Implementation of gates with simple verilog codes.

Combinatorial and Arithmetic Circuits - Combinatorial Logic Systems - Comparators, Multiplexers, Demultiplexers, Encoder, Decoder. Half and Full Adders, Subtractors, Serial and Parallel Adders, BCD Adder. Modeling and simulation of combinatorial circuits with verilog codes at the gate level.

Sequential Logic Circuits - Building blocks like S-R, JK and Master-Slave JK FF, Edge triggered FF, Conversion of Flip Flops, Excitation table and characteristic equation. Implementation with verilog codes. Ripple and Synchronous counters and implementation in verilog, Shift registers-SIPO, SISO, PISO, PIPO. Shift Registers with parallel Load/Shift, Ring



counter and Johnsons counter. Asynchronous and Synchronous counter design, Mod N counter. Modeling and simulation of flip flops and counters in verilog.

Logic families and its characteristics - TTL, ECL, CMOS - Electrical characteristics of logic gates – logic levels and noise margins, fan-out, propagation delay, transition time, power consumption and power-delay product. TTL inverter - circuit description and operation; CMOS inverter - circuit description and operation; Structure and operations of TTL and CMOS gates; NAND in TTL and CMOS, NAND and NOR in CMOS.

v) a) TEXT BOOKS

- 1) Morris Mano, *Digital Design*, Prentice Hall of India, 6/e, 2013.
- 2) Donald D Givone, *Digital Principles and Design*, Tata McGraw Hill, 2007.
- 3) Samir Palnikar, *Verilog HDL: A Guide to Digital Design and Synthesis*, Sunsoft Press, 2003.

b) REFERENCES

- 1) Ronald J Tocci, *Digital Systems*, Pearson Education, 11/e, 2010.
- 2) Anand Kumar, *Fundamentals of Digital Circuits*, 4/e, 2016.
- 3) Wakerly J.F., *Digital Design: Principles and Practices*, Pearson India, 4/e, 2008
- 4) Thomas L Floyd, *Digital Fundamentals*, Pearson Education, 11/e, 2018.

vi) COURSE PLAN

Module	Contents	No. of hours
I	Binary and hexadecimal number systems; Methods of base conversions; Binary and hexadecimal arithmetic; Representation of signed numbers; Fixed and floating point numbers; Binary coded decimal codes; Gray codes; Excess 3 code. Alphanumeric codes: ASCII. Basics of verilog -- basic language elements: identifiers, data objects, scalar data types, operators.	12
II	Boolean postulates and laws – Logic Functions and Gates De-Morgan's Theorems, Principle of Duality, Minimization of Boolean expressions, Sum of Products (SOP), Product of Sums (POS), Canonical forms, Karnaugh map Minimization. Modeling in verilog, Implementation of gates with simple verilog codes.	12
III	Combinatorial Logic Systems - Comparators, Multiplexers, Demultiplexers, Encoder, Decoder. Half and Full Adders, Subtractors, Serial and Parallel Adders, BCD Adder. Modeling and simulation of combinational circuits with verilog codes at the gate level.	12
IV	Building blocks like S-R, JK and Master-Slave JK FF, Edge triggered FF, Conversion of Flipflops, Excitation table and characteristic equation.	12



	Implementation with verilog codes. Ripple and Synchronous counters and implementation in verilog, Shift registers-SIPO, SISO,PISO, PIPO. Shift Registers with parallel Load/Shift, Ring counter and Johnsons counter. Asynchronous and Synchronous counter design, Mod N counter. Modeling and simulation of flip flops and counters in verilog.	
V	TTL, ECL, CMOS - Electrical characteristics of logic gates – logic levels and noise margins, fan-out, propagation delay, transition time, power consumption and power-delay product. TTL inverter - circuit description and operation; CMOS inverter - circuit description and operation; Structure and operations of TTL and CMOS gates; NAND in TTL and CMOS, NAND and NOR in CMOS.	12
	Total hours	60

vii) ASSESSMENT PATTERN**Mark distribution**

Total Marks	Continuous Internal Evaluation Marks	End Semester Evaluation Marks	End Semester Examination Duration
150	50	100	3 Hours

Continuous Internal Evaluation Pattern:

Attendance	10 Marks
Continuous Assessment Tests (2 numbers)	25 Marks
Assignment/Quiz/Course project	15 Marks

It is mandatory that a *course project* shall be undertaken by a student for this subject. Instead of two assignments, two evaluations will be performed on the course project along with continuous assessment tests, each carrying 5 marks. Upon successful completion of the project, a brief report must be submitted by the student which will be evaluated for 5 marks.

End Semester Examination Pattern:

There will be two parts; Part A and Part B. Part A contain 10 questions with 2 questions from each module, having 3 marks for each question. Students should answer all questions. Part B contains 2 questions from each module of which student should answer any one. Each question can have maximum 2 sub-divisions and carry 14 marks.



Course Code	Course Name	Category	L	T	P	Credit	Year of Introduction
EC1U20C	NETWORK THEORY	PCC	3	1	0	4	2020

i) **PREREQUISITE:** ES0U10D: Basics of Electrical and Electronics Engineering, MA0U10B: Vector calculus, differential equations and transforms.

ii) COURSE OVERVIEW

The goal of this course is to expose the students to solve dc and ac networks using network theorems, to apply Laplace transform to determine the transient response of networks subjected to test signals and to analyse single and two ports network functions and its time domain response.

iii) COURSE OUTCOMES

After the completion of the course, the student will be able to:

Course Outcomes	Description	Level
CO 1	Apply the loop /nodal analysis/network theorems to solve dc and ac networks.	Apply
CO 2	Explain Laplace transform, properties and theorems.	Understand
CO 3	Apply Laplace Transforms to determine the transient behaviour of RLC networks.	Apply
CO 4	Use pole-zero plot to study the time domain response of a network.	Apply
CO 5	Analyse two port network parameters.	Apply

iv) SYLLABUS

Mesh and Node Analysis

Mesh and node analysis of network containing independent and dependent sources. Supermesh and Supernode analysis. Steady-state AC analysis using Mesh and Node analysis

Network Theorems

Thevenin's theorem, Norton's theorem, Superposition theorem, Reciprocity theorem, Maximum power transfer theorem. (applied to both dc and ac circuits having dependent source).

Application of Laplace Transforms

Review of Laplace Transforms and Inverse Laplace Transforms, Initial value theorem & Final value theorem, Transformation of basic signals and circuits into s-domain. Transient analysis of RL, RC, and RLC networks with impulse, step and sinusoidal inputs (with and without initial conditions). Analysis of networks with transformed impedance and dependent sources.

Network functions

Network functions for the single port and two port network. Properties of driving point and transfer functions. Significance of Poles and Zeros of network functions, Time domain response from pole zero plot. Impulse Function & Response. Network functions in the sinusoidal steady state, Magnitude and Phase response.

**Two port network Parameters**

Impedance, Admittance, Transmission and Hybrid parameters of two port networks. Interrelationship among parameter sets. Series and parallel connections of two port networks. Reciprocal and Symmetrical two port network. Characteristic impedance, Image impedance and propagation constant (derivation not required).

v) (a) TEXT BOOKS

- 1) Valkenburg V., “Network Analysis”, Pearson, 3/e, 2019.
- 2) Sudhakar A, Shyammohan S. P., “Circuits and Networks- Analysis and Synthesis”, McGraw Hill,5/e,2015.

(b) REFERENCES

- 1) Edminister, “Electric Circuits – Schaum’s Outline Series”, McGraw-Hill, 2009.
- 2) Ravish R., “Network Analysis and Synthesis”, 2/e, McGraw-Hill, 2015.
- 3) William D. Stanley, “Network Analysis with Applications”, 4/e, Pearson, 2006.
- 4) K. S. Suresh Kumar, “Electric Circuits and Networks”, Pearson, 2008.

vi) COURSE PLAN

Module	Contents	No. of hours
1.	Mesh and node analysis of network containing independent and dependent sources for dc and ac sources. Super mesh and super node analysis.	12
2.	Network theorems applied to dc and phasor circuits: Thevenin’s theorem, Norton’s theorem, Superposition theorem, Reciprocity theorem, Millman’s theorem, Maximum power transfer theorem.	12
3.	Laplace Transforms and inverse Laplace transform, initial value and final value theorem. Transformation of basic signals and circuits into s-domain. Transient analysis of RL, RC, and RLC networks with impulse, step, and sinusoidal inputs (with and without initial conditions). Analysis of networks with transformed impedance and dependent sources.	12
4.	Network functions for the single port and two port network. Properties of driving point and transfer functions. Significance of Poles and Zeros of network functions, time domain response from pole zero plot, impulse function & response. Network function in sinusoidal state, Magnitude and Phase response.	12
5.	Impedance, admittance, transmission and hybrid parameters of two port network, Interrelationship among parameter sets. Series and parallel connections of two port networks. Reciprocal and Symmetrical two port network. Characteristic impedance, image impedance and propagation constant (derivation not required)	12
Total hours		60

**Simulation assignment:**

One assignment may be a simulation of steady state or transient analysis of R, L and C circuits.

viii) ASSESSMENT PATTERN**Mark distribution**

Total Marks	Continuous Internal Evaluation Marks	End Semester Evaluation Marks	End Semester Examination Duration
150	50	100	3 Hours

Continuous Internal Evaluation Pattern:

Attendance	10 Marks
Continuous Assessment Tests (2 numbers)	25 Marks
Assignment/Quiz/Course project	15 Marks

End Semester Examination Pattern:

There will be two parts; Part A and Part B. Part A contain 10 questions with 2 questions from each module, having 3 marks for each question. Students should answer all questions. Part B contains 2 questions from each module of which student should answer any one. Each question can have maximum 2 sub-divisions and carry 14 marks.



Course Code	Course Name	Category	L	T	P	Credit	Year of Introduction
HS0U20A	PROFESSIONAL ETHICS	HSC	2	0	0	2	2020

i) COURSE OVERVIEW

To enable students to create awareness on ethics and human values.

ii) COURSE OUTCOMES

After the completion of the course, the student will be able to:

Course Outcomes	Description	Level
CO 1	Infer the core values that shape the ethical behaviour of a professional.	Understand
CO 2	Apply philosophical concepts discussed in the course to personal and contemporary issues.	Apply
CO 3	Explain the role and responsibility of engineers in technological development without compromising personal ethics and legal ethics.	Understand
CO 4	Solve moral and ethical problems through exploration and assessment by established experiments.	Apply
CO 5	Demonstrate the concept of Corporate Social Responsibility, and explore its relevance to ethical business activity	Understand
CO 6	Apply the knowledge of human values and social values to contemporary ethical values and global issues.	Apply

iii) SYLLABUS

Morals, values and Ethics – Integrity- Academic Integrity-Work Ethics- Service Learning- Civic Virtue- Respect for others- Living peacefully- Caring and Sharing- Honestly- Courage- Cooperation commitment- Empathy-Self Confidence -Social Expectations.

Senses of Engineering Ethics - Variety of moral issues- Types of inquiry- Moral dilemmas – Moral Autonomy – Kohlberg’s theory- Gilligan’s theory- Consensus and Controversy- Profession and Professionalism- Models of professional Roles-Theories about right action – Self-Interest-Customs and Religion- Uses of Ethical Theories.

Engineering as Experimentation – Engineers as responsible Experimenters- Codes of Ethics- Plagiarism- A balanced outlook on law - Challenges case study- Bhopal gas tragedy.

Collegiality and loyalty – Managing conflict- Respect for authority- Collective bargaining- Confidentiality- Role of confidentiality in moral Integrity-Conflicts of interest- Occupational crime- Professional rights- Employee right- IPR Discrimination.Multinational Corporations- Environmental Ethics- Business Ethics- Computer Ethics -Role in Technological Development- Engineers as Managers- Consulting Engineers- Engineers as Expert witnesses and Advisors- Moral leadership.

**iv) (a) TEXT BOOKS**

- 1) M Govindarajan, S Natarajan and V S Senthil Kumar, Engineering Ethics, PHI Learning Private Ltd, New Delhi, 2012.
- 2) R S Naagarazan, A text book on professional ethics and human values, New age international (P) limited, New Delhi, 2006.

(b) REFERENCES

- 1) Mike W Martin and Roland Schinzinger, Ethics in Engineering, 4th edition, Tata McGraw Hill Publishing Company Pvt Ltd, New Delhi, 2014.
- 2) Charles D Fledder mann, Engineering Ethics, Pearson Education/ Prentice Hall of India, New Jersey, 2004.
- 3) Charles E Harris, Michael S Protchard and Michael J Rabins, Engineering Ethics- Concepts and cases, Wadsworth Thompson Learning, United states, 2005.
- 4) <http://www.slideword.org/slidestag.aspx/human-values-and-Professional-ethics>.

v) COURSE PLAN

Module	Contents	No. of hours
I	Morals, values and Ethics, Integrity, Academic Integrity, Work Ethics Service Learning, Civic Virtue, Respect for others, Living peacefully Caring and Sharing, Honesty, Courage, Co-operation commitment Empathy, Self Confidence, Social Expectations	6
II	Senses of Engineering Ethics, Variety of moral issues, Types of Inquiry-Moral dilemmas, Moral Autonomy, Kohlberg's theory Gilligan's theory, Consensus and Controversy, Profession & Professionalism, Models of professional roles, Theories about right action-Self-interest-Customs and Religion, Uses of Ethical Theories	6
III	Engineering as Experimentation, Engineers as responsible Experimenters-Codes of Ethics, Plagiarism, A balanced outlook on law-Challenger case study, Bhopal gas tragedy	6
IV	Collegiality and loyalty, Managing conflict, Respect for authority Collective bargaining, Confidentiality, Role of confidentiality in moral integrity, Conflicts of interest-Occupational crime, Professional rights, Employee right, IPR, Discrimination	6
V	Multinational Corporations, Environmental Ethics, Business Ethics, Computer Ethics-Role in Technological Development, Moral leadership-Engineers as Managers, Consulting Engineers, Engineers as Expert witnesses and advisors	6
	Total Hours	30

**vi) ASSESSMENT PATTERN****Mark distribution**

Total Marks	Continuous Internal Evaluation Marks	End Semester Evaluation Marks	End Semester Examination Duration
150	50	100	3 Hours

Continuous Internal Evaluation Pattern:

Attendance	10 Marks
Continuous Assessment Tests (2 numbers)	25 Marks
Assignment/Quiz/Course project	15 Marks

End Semester Examination Pattern:

There will be two parts; Part A and Part B. Part A contain 10 questions with 2 questions from each module, having 3 marks for each question. Students should answer all questions. Part B contains 2 questions from each module of which student should answer any one. Each question can have maximum 2 sub-divisions and carry 14 marks.



Course Code	Course Name	Category	L	T	P	Credit	Year of Introduction
NC0U20A	SUSTAINABLE ENGINEERING	MNC	2	0	0	-	2020

i) COURSE OVERVIEW

The objective of this course is to expose the students to the concept of sustainability, the global initiatives towards attaining sustainable development goals and the various sustainable practices. The students should realize the potential of technology in addressing environmental issues and bringing in sustainable solutions.

ii) COURSE OUTCOMES

After the completion of the course, the student will be able to:

Course Outcomes	Description	Level
CO 1	Explain the relevance and the concept of sustainability and the global initiatives towards attaining sustainable development.	Understand
CO 2	Identify sustainable solutions for different types of environmental pollution problems	Apply
CO 3	Discuss the environmental regulations and standards, various tools for environmental management and clean development mechanism.	Apply
CO 4	Explain the concept of circular economy, bio-mimicking and the sustainable framework developed in industrial ecology and industrial symbiosis.	Apply
CO 5	Choose the best practice of nonconventional and sustainable energy depending on the available resources and its utilization.	Apply
CO6	Demonstrate the broad perspective of sustainable practices applicable for energy efficient buildings, green engineering, sustainable cities, sustainable urbanization, and sustainable transport.	Apply

iii) SYLLABUS

Sustainability- need and concept, Technology and Sustainable Development, Sustainable Development Goals.

Environmental Pollution: Natural resources and their pollution, Carbon credits, Zero waste concept and 3 R concepts, Clean Development Mechanism: Carbon Trading and Carbon footprint, legal provisions for environmental protection.

Environmental management standards: ISO 14001:2015 framework, Life Cycle Analysis, Circular economy, Bio-mimicking, Environment Impact Assessment (EIA), Industrial ecology and industrial symbiosis.

Resources and its utilization: Basic concepts of Conventional and non-conventional energy.

Sustainability practices: Sustainable habitat, Green buildings, green materials, Sustainable urbanization.

**iv) (a) TEXTBOOKS**

- 1) Bradley, A.S., Adebayo,A.O., Maria, P., *Engineering applications in sustainable design and development*, Cengage learning, 1st Edition, 2015.
- 2) Allen, D. T. and Shonnard, D. R., *Sustainability Engineering: Concepts, Design and Case Studies*, Prentice Hall, 1st Edition, 2011
- 3) Purohit, S.S., *Green Technology: An Approach For Sustainable Environment*, Agrobios (India), 1st Edition, 2021.
- 4) Janine, M.B., *Biomimicry: Innovation Inspired by Nature*, William Morrow Paperbacks, 2002

(b) REFERENCES

- 1) Environment Impact Assessment Guidelines, Notification of Government of India, 2006.
- 2) ECBC Code 2007, Bureau of Energy Efficiency, New Delhi Bureau of Energy Efficiency Publications-Rating System, TERI Publications - GRIHA Rating System.

v) COURSE PLAN

Module	Contents	No. of hours
I	Sustainability: Introduction, concept, evolution of the concept; Social, environmental and economic sustainability concepts; Sustainable development, Nexus between Technology and Sustainable development; Millennium Development Goals (MDGs) and Sustainable Development Goals (SDGs).	6
II	Environmental Pollution: Air Pollution and its effects, Water pollution and its sources, Zero waste concept and 3 R concepts in solid waste management; Greenhouse effect, Global warming, Climate change, Ozone layer depletion, Clean Development Mechanism (CDM):Carbon credits, carbon trading and carbon footprint, legal provisions for environmental protection.	6
III	Environmental management standards: ISO 14001:2015 frame work and benefits, Scope and goal of Life Cycle Analysis (LCA), Circular economy, Bio-mimicking, Environment Impact Assessment (EIA), Industrial ecology and industrial symbiosis.	6
IV	Resources and its utilisation: Basic concepts of Conventional and non-conventional energy, General idea about solar energy, Fuel cells, Wind energy, Small hydro plants, bio-fuels, Energy derived from oceans and Geothermal energy.	6
V	Sustainability practices: Basic concept of sustainable habitat, Methods for increasing energy efficiency in buildings, Green Engineering, Sustainable Urbanisation, Sustainable cities, Sustainable transport.	6
	Total hours	30

**vi) ASSESSMENT PATTERN****Mark distribution**

Total Marks	Continuous Internal Evaluation Marks	End Semester Evaluation Marks	End Semester Examination Duration
150	50	100	3 Hours

Continuous Internal Evaluation Pattern:

Attendance	10 Marks
Continuous Assessment Tests (2 numbers)	25 Marks
Assignment/Quiz/Course project	15 Marks

End Semester Examination Pattern:

There will be two parts; Part A and Part B. Part A contain 10 questions with 2 questions from each module, having 3 marks for each question. Students should answer all questions. Part B contains 2 questions from each module of which student should answer any one. Each question can have maximum 2 sub-divisions and carry 14 marks.



Course Code	Course Name	Category	L	T	P	Credit	Year of Introduction
EC1U28A	SCIENTIFIC COMPUTING LAB	PCC	0	0	3	2	2020

i) **PREREQUISITE:** MA0U10A- Linear Algebra and Calculus,
MA0U10B -Vector calculus, Differential Equations and Transforms.

ii) **COURSE OVERVIEW:**

Objective of the course is to translate the mathematical concepts into system design using different computing tools.

iii) **COURSE OUTCOMES**

After the completion of the course, the student will be able to:

Course Outcomes	Description	Level
CO 1	Use a programming language for realization of arithmetic functions, vectorized computing and data visualization.	Apply
CO 2	Solve an array/matrix with matrix decomposition.	Apply
CO 3	Implement numerical integration and differentiation, ordinary differential equations for engineering applications.	Apply
CO 4	Implement the periodic functions using sinusoids.	Apply
CO 5	Examine random processes and their statistics.	Analyze

iv) **SYLLABUS**

Familiarization of a programming language for scientific computing and data visualization.

Solve ordinary differential equations, numerical integration and differentiation for engineering applications.

Solve periodic functions using Fourier analysis.

Solve array/matrix with matrix decomposition.

Simulate various random processes and compute absolute error to understand the law of large numbers.

v) **REFERENCES**

- 1) Peter I. Kattan, MATLAB for Beginners: A Gentle Approach, Createspace Independent Publications, 2008

**vi) COURSE PLAN**

Experiment No.	List of Exercises/Experiments	No. of hours
I	Familiarization of the Computing Tool. 1. Needs and requirements in scientific computing 2. Familiarization of a programming language like Python/R/ MATLAB/SCILAB/LabVIEW for scientific computing 3. Familiarization of data types in the language used. 4. Familiarization of the syntax of while, for, if statements. 5. Basic syntax and execution of small scripts.	5
II	Familiarization of Scientific Computing. 1. Functions with examples. 2. Basic arithmetic functions such as abs, sine, real, image, complex, sinc etc. using built in modules. 3. Vectorized computing without loops for fast scientific applications.	5
III	Realization of Arrays and Matrices. 1. Realize one dimensional array of real and complex numbers 2. Stem and continuous plots of real arrays using matplotlib/GUIs/charts. 3. Realization of two-dimensional arrays and matrices and their visualizations 4. Inverse of a square matrix and the solution of the matrix equation 5. Computation of the rank and eigen values a Matrix 6. Singular value decomposition 7. Plot the absolute error	5
IV	Numerical Differentiation and Integration. 1. Realize the functions $\sin t$, $\cos t$, $\sinh t$ and $\cosh t$ 2. Compute the first and second derivatives of these functions using built-in tools such as grad. 3. Plot the derivatives over the respective functions and appreciate. 4. Familiarize the numerical integration tools in the language you use. 5. Realize and plot the function. 6. Compare general integration tool with trapezoidal and Simpson	6



	method.	
V	<p>Solution of Ordinary Differential Equations.</p> <ol style="list-style-type: none"> 1.Solve the _first order and second order differential equation. 2. Solve for the current transient through the RC network and a series RLC network. 	6
VI	<p>Data visualization of simple functions /signals.</p> <ol style="list-style-type: none"> 1. Draw stem plots, line plots, box plots, bar plots and scatter plots with random data. 2. Plot the histogram of a random data. 3. Create legends in plots. 4. Realize a vector 5. Implement and plot the functions 	6
VII	<p>Convergence of Fourier Series.</p> <ol style="list-style-type: none"> 1.Realizethe Fourier series $\frac{4}{\pi} [1 - \frac{1}{3} \cos \cos \frac{2\pi 3t}{T} + \frac{1}{5} \cos \cos \frac{2\pi 5t}{T} - \frac{1}{7} \cos \cos \frac{2\pi 7t}{T} + \dots$ 2.Realize the vector t=[0.100] with an increment of 0.01 and keep T=20. 3.Plot the first 3 or 4 terms on the same graphic window and understand how the smooth sinusoids add up to a discontinuous square function. 4.Compute and plot the series for the first 10, 20, 50 and 100 terms and understand the lack of convergence at the points of discontinuity. 	6
VIII	<p>Coin Toss and the Level Crossing Problem</p> <ol style="list-style-type: none"> 1. Simulate a coin toss that maps a head as 1 and tail as 0. 2. Toss the coin N = 100, 500,1000, 5000 and 500000 times and compute the probability (p) of head in each case. 3. Compute the absolute error and understand the law of large numbers. 4. Create a uniform random vector with maximum magnitude 10, plot and observe. 5. Set a threshold and count how many times the random function has crossed threshold. 	6
	Total hours	45

**vii) ASSESSMENT PATTERN****Mark distribution**

Total Marks	Continuous Internal Evaluation Marks	End Semester Evaluation Marks	End Semester Examination Duration
150	75	75	3 Hours

Continuous Internal Evaluation Pattern:

Attendance	15 Marks
Continuous Assessment	30 Marks
Internal Test (Immediately before the II internal test)	30 Marks

End Semester Examination Pattern:

Preliminary work	15 marks
Implementing the work/Conducting the experiment	20 marks
Performance, result and inference (usage of equipment and troubleshooting):	15 marks
Viva voce	20 marks
Record	5 Marks



Course Code	Course Name	Category	L	T	P	Credit	Year of Introduction
EC1U28B	LOGIC DESIGN LAB	PCC	0	0	3	2	2020

i) **PREREQUISITE:** ES0U18B - Electrical and Electronics Workshop

ii) **COURSE OVERVIEW**

Objective of the course is to familiarize the students with the Digital Logic Design through the implementation of Logic Circuits using ICs of basic logic gates and HDL based Digital Design Flow.

iii) **COURSE OUTCOMES**

After the completion of the course, the student will be able to:

Course Outcomes	Description	Level
CO1	Demonstrate the functioning of various combinational and sequential circuits using ICs	Apply
CO2	Apply an industry compatible hardware description language to implement digital circuits	Apply
CO3	Build digital circuits on FPGA boards and connect external hardware to the boards	Apply

iv) **SYLLABUS**

Design and realization of half /full adder and subtractor, 4 Bit adder subtractor, Study of Flip Flops: S-R, D, T, JK and Master Slave JK FF, Asynchronous counters, Synchronous Counters, Multiplexers and De-multiplexers, Random Sequence generator.

Digital circuit design with Verilog and implementation in FPGAs- Adders, Multiplexers and De-multiplexers, Flip Flops and counters, Asynchronous and Synchronous Counters in FPGA, Universal Shift Register in FPGA, BCD to Seven Segment Decoder in FPGA

v) **REFERENCES**

- 1) Roth C.H., Fundamentals of Logic Design, Jaico Publishers. V Ed., 2009
- 2) Taub & Schilling: Digital Integrated Electronics, MGH, 2017.
- 3) W. I. Fletcher, An Engineering Approach to Digital Design, Prentice-Hall, Inc., Englewood Cliffs, NJ, 1980
- 4) Tocci, R. J. and Widner, N. S., Digital Systems - Principles and Applications, Prentice Hall, 10thEd., 2007
- 5) Wakerly J F, Digital Design: Principles and Practices, Prentice-Hall, 2nd Ed., 2002
- 6) Mano M. M., Computer System Architecture, Prentice Hall 1993.
- 7) Katz R, Contemporary Logic Design, Addison Wesley, 1993.
- 8) Lewin D. & Protheroe D., Design of Logic Systems, Chapman & Hall, University and Professional Division, 1992, II Ed.

v) **COURSE PLAN**

Experiment No.	List of exercises/experiments	No. of hours
	PART A: The following experiments can be conducted on breadboard or trainer kits.	
I	Design and Realization of half /full adder and subtractor using logic gates.	3
II	4 bit adder/subtractor and BCD adder using 7483.	3
III	Study of Flip Flops: S-R, D, T, JK and Master Slave JK FF using NAND gates.	3
IV	Asynchronous counters (using ICs 7476).	3
V	Synchronous Counters (using ICs 7473/7476).	3
VI	Realization of counters using IC's (7490, 7492, 7493).	3
VII	Multiplexers and De-multiplexers using gates and ICs. (74150, 74154) 12. Realization of combinational circuits using MUX & DEMUX.	3
VIII	Random Sequence generator using LFSR.	3
	Part B: The following experiments aim at training the students in digital circuit design with Verilog and implementation in FPGAs.	
I	Realization of Logic Gates and Familiarization of FPGA board.	3
II	Adders in Verilog (a) Development of Verilog modules for half adder in 3 modelling styles (dataflow/structural/ behavioural). (b) Development of Verilog modules for full adder in structural modelling using half adder.	3
III	Mux and Demux in Verilog (a) Development of Verilog modules for a 4x1 MUX. (b) Development of Verilog modules for a 1x4 DEMUX.	3
IV	Flipflops and Counters (a) Development of Verilog modules for SR, JK and D flip flops. (b) Development of Verilog modules for a binary decade/Johnson/Ring counters	3



V	Asynchronous and Synchronous Counters in FPGA (a) Make a design of a 4-bit up down ripple counter using T-flip-flops in the previous experiment, implement and test them on the FPGA board. (b) Make a design of a 4-bit up down synchronous counter using T-flip-flops in the previous experiment, implement and test them on the FPGA board.	3
VI	Universal Shift Register in FPGA (a) Make a design of a 4-bit universal shift register using D-flip-flops , implement and test them on the FPGA board. (b) Implement ring and Johnson counters with it.	3
VII	BCD to Seven Segment Decoder in FPGA (a) Make a gate level design of a seven segment decoder, write to FPGA and test its functionality. (b) Test it with switches and seven segment display. Use output ports for connection to the display.	3
	Total hours	45

vi) **ASSESSMENT PATTERN****Mark distribution**

Total Marks	Continuous Internal Evaluation Marks	End Semester Evaluation Marks	End Semester Examination Duration
150	75	75	3 Hours

Continuous Internal Evaluation Pattern:

Attendance	15 Marks
Continuous Assessment	30 Marks
Internal Test (Immediately before the II internal test)	30 Marks

End Semester Examination Pattern:

Preliminary work	15 marks
Implementing the work/Conducting the experiment	20 marks
Performance, result and inference (usage of equipment and troubleshooting):	15 marks
Viva voce	20 marks
Record	5 Marks



MINORS



Course Code	Course Name	Category	L	T	P	Credit	Year of Introduction
EC0 M20A	ELECTRONIC CIRCUITS	MINOR (Basket-1)	3	1	0	4	2020

i) COURSE OVERVIEW:

This course introduces the concepts of basic electronic circuits and develop the skill of designing amplifiers, oscillators, and regulators.

ii) COURSE OUTCOMES

After the completion of the course, the student will be able to:

Course Outcomes	Description	Level
CO 1	Explain the working of simple circuits using diodes, resistors, and capacitors.	Understand
CO 2	Analyse the transistor biasing circuits.	Analyze
CO 3	Design amplifier and oscillator circuits.	Apply
CO 4	Explain the working of MOSFETS, Power supplies, D/A and A/D converters.	Understand
CO 5	Design circuits using operational amplifiers and 555 IC.	Apply

iii) SYLLABUS

Wave shaping circuits: Sinusoidal and non-sinusoidal wave shapes, Principle and working of RC differentiating and integrating circuits, Clipping circuits - Positive, negative, and biased clipper. Clamping circuits - Positive, negative, and biased clamper.

Transistor biasing: Introduction, operating point, concept of load line, thermal stability (derivation not required), fixed bias, self-bias, voltage divider bias.

MOSFET- Structure, Enhancement and Depletion types, principle of operation and characteristics.

Amplifiers: Classification of amplifiers, RC coupled amplifier – design and working, voltage gain and frequency response. Multistage amplifiers - effect of cascading on gain and bandwidth. Feedback in amplifiers - Effect of negative feedback on amplifiers.

MOSFET Amplifier- Circuit diagram, design and working of common source MOSFET amplifier.

Oscillators: Classification, criterion for oscillation, Wien bridge oscillator, Hartley, and Crystal oscillator. (design equations and working of the circuits; analysis not required).

Regulated power supplies: Review of simple zener voltage regulator, series voltage regulator, 3 pin regulators-78XX and 79XX, DC to DC conversion, Circuit/block diagram and working of SMPS.



Operational amplifiers: Characteristics of op-amps (gain, bandwidth, slew rate, CMRR, offset voltage, offset current), comparison of ideal and practical op-amp (IC741), Applications of op-amps- scale changer, sign changer, adder/summing amplifier, subtractor, integrator, differentiator, Comparator, Instrumentation amplifier.

Integrated circuits: D/A and A/D convertors – important specifications, Sample and hold circuit, R-2R ladder type D/A convertors. Flash and sigma-delta type A/D convertors.

Circuit diagram and working of Timer IC555, astable and monostable multivibrators using 555.

iv) a) TEXT BOOKS

- 1) Boylestad and L Nashelsky, *Electronic Devices and Circuit Theory*, Pearson, 11/e, 2008.
- 2) Salivahanan S. and V. S. K. Bhaaskaran, *Linear Integrated Circuits*, Tata McGraw Hill, 3/e, ` 2008.

b) REFERENCES

- 1) David A Bell, *Electronic Devices and Circuits*, Oxford University Press, 2008.
- 2) Neamen D., *Electronic Circuits, Analysis and Design*, 3/e, TMH, 2007.
- 3) Millman J. and C. Halkias, *Integrated Electronics*, 2/e, McGraw-Hill, 2011.
- 4) Ramakant A Gayakwad, *Op-Amps and Linear Integrated Circuits*, 4/e, PHI, 2000.
- 5) K.Gopakumar, *Design and Analysis of Electronic Circuits*, Phasor Books, Kollam, 2013

v) COURSE PLAN

Module	Contents	No. of hours
I	<p>Wave shaping circuits: Sinusoidal and non-sinusoidal wave shapes, Principle and working of RC differentiating and integrating circuits, Clipping circuits - Positive, negative, and biased clipper. Clamping circuits - Positive, negative, and biased clamper.</p> <p>Transistor biasing: Introduction, operating point, concept of load line, thermal stability (derivation not required), fixed bias, self-bias, voltage divider bias.</p>	12
II	<p>MOSFET- Structure, Enhancement and Depletion types, principle of operation and characteristics.</p> <p>Amplifiers: Classification of amplifiers, RC coupled amplifier – design and working, voltage gain and frequency response. Multistage amplifiers - effect of cascading on gain and bandwidth.</p> <p>Feedback in amplifiers - Effect of negative feedback on amplifiers.</p> <p>MOSFET Amplifier- Circuit diagram, design and working of common source MOSFET amplifier.</p>	12
III	<p>Oscillators: Classification, criterion for oscillation, Wien bridge oscillator, Hartley, and Crystal oscillator. (design equations and working of the circuits; analysis not required).</p>	12



	Regulated power supplies: Review of simple zener voltage regulator, series voltage regulator, 3 pin regulators-78XX and 79XX, DC to DC conversion, Circuit/block diagram and working of SMPS.	
IV	Operational amplifiers: Characteristics of op-amps (gain, bandwidth, slew rate, CMRR, offset voltage, offset current), comparison of ideal and practical op-amp (IC741), Applications of op-amps- scale changer, sign changer, adder/summing amplifier, subtractor, integrator, differentiator, Comparator, Instrumentation amplifier.	12
V	Integrated circuits: D/A and A/D convertors – important specifications, Sample and hold circuit, R-2R ladder type D/A convertors. Flash and sigma-delta type A/D convertors. Circuit diagram and working of Timer IC555 , astable and monostable multivibrators using 555	12
	Total hours	60

vi) ASSESSMENT PATTERN**Mark distribution**

Total Marks	Continuous Internal Evaluation Marks	End Semester Evaluation Marks	End Semester Examination Duration
150	50	100	3 Hours

Continuous Internal Evaluation Pattern:

Attendance	10 Marks
Continuous Assessment Tests (2 numbers)	25 Marks
Assignment/Quiz/Course project	15 Marks

End Semester Examination Pattern:

There will be two parts; Part A and Part B. Part A contain 10 questions with 2 questions from each module, having 3 marks for each question. Students should answer all questions. Part B contains 2 questions from each module of which student should answer any one. Each question can have maximum 2 sub-divisions and carry 14 marks.



Course Code	Course Name	Category	L	T	P	Credit	Year of Introduction
ECOM20B	ANALOG COMMUNICATION	MINOR (Basket-2)	4	0	0	4	2020

i) COURSE OVERVIEW

The goal of this course is to expose the students to different analog modulation schemes namely amplitude modulation and frequency modulation. Also it gives a brief overview on signal classification, LTI systems and Fourier Transform. It also gives a broad vision on different types of AM and FM transmitters and Receivers.

ii) COURSE OUTCOMES

After the completion of the course, the student will be able to:

Course Outcomes	Description	Level
CO 1	Discuss various components, sources of noise and it's effect in a communication system.	Understand
CO 2	Explain various analog modulation schemes in a communication system.	Understand
CO 3	Apply the knowledge of signals and system/modulation to study the behavior of a communication system.	Apply
CO 4	Discuss various transmitter and receiver systems of AM and FM.	Understand

iii) SYLLABUS

Introduction, Elements of communication systems, Examples of analog communication systems, Frequency bands, Need for modulation.

Noise in communication system, Definitions of Thermal noise (white noise), Various types of noise -- Shot noise, Partition noise, Flicker noise, Burst noise, (No analysis required) Signal to noise ratio, Noise factor, Noise temperature, Narrow band noise.

Brief overview of signals and systems -- Signals, Classification of signals, Energy and power of signals, Basic signal operations, Impulse function, Properties of impulse function, Convolution, LTI system, Fourier Transform, Basic properties, Using Fourier transform to study LTI system.

Amplitude modulation (AM), Double-side band suppressed carrier (DSB-SC) modulation Single sideband modulation (SSB) – spectrum, power, efficiency of all the three variants. (Study of only tone modulation in DSB-SC, AM, and SSB.) Amplitude-modulator implementations – switching modulator, balanced modulator. AM demodulators –Coherent demodulator. Envelope detector.

Frequency modulation – modulation index, frequency deviation, average power, spectrum of tone modulated FM. Heuristics for bandwidth of FM. Narrow band FM and wide-band



FM. FM generation: Varactor diode modulator, Armstrong's method. FM demodulation – slope detection, PLL demodulator.

Superheterodyne receiver, Principle of Carrier synchronization using PLL, NTSC Television broadcasting.

iv)(a) TEXT BOOKS

- 1) Kennedy, Davis, *Electronic Communication Systems*, 4th Edition, Tata McGraw Hill, 2008
- 2) Wayne Tomasi, *Electronic Communication Systems – Fundamentals through Advanced*, 5th edition, Pearson, 2008.
- 3) B.P.Lathi, Zhi Ding, *Modern Digital and Analog Communication Systems*, 4th edition, Oxford University Press, 2017.

(b) REFERENCES

- 1) Leon W. Couch, *Digital and Analog Communication Systems*, 8th edition, Prentice Hall, 2013

v) COURSE PLAN

Module	Contents	No. of hours
I	Introduction, Elements of communication systems, Examples of analog communication systems, Frequency bands, Need for modulation. Noise in communication system, Definitions of Thermal noise (white noise), Various types of noise -- Shot noise, Partition noise, Flicker noise, Burst noise, (No analysis required) Signal to noise ratio, Noise factor, Noise temperature, Narrow band noise.	12
II	Brief overview of signals and systems -- Signals, Classification of signals, Energy and power of signals, Basic signal operations, Impulse function, Properties of impulse function, Convolution, LTI system, Fourier Transform, Basic properties, Using Fourier transform to study LTI system.	12
III	Amplitude modulation (AM), Double-side band suppressed carrier (DSB-SC) modulation Single sideband modulation (SSB) – spectrum, power, efficiency of all the three variants. (Study of only tone modulation in DSB-SC, AM, and SSB.) Amplitude-modulator implementations – switching modulator, balanced modulator. AM demodulators -- Coherent demodulator. Envelope detector.	12
IV	Frequency modulation – modulation index, frequency deviation, average power, spectrum of tone modulated FM. Heuristics for bandwidth of FM. Narrow band FM and wide-band FM. FM generation: Varactor diode modulator, Armstrong method. FM demodulation – slope detection, PLL demodulator	12
V	Super heterodyne receiver, Principle of Carrier synchronization using PLL, NTSC Television broadcasting.	12
	Total hours	60

**vi) ASSESSMENT PATTERN****Mark distribution**

Total Marks	Continuous Internal Evaluation Marks	End Semester Evaluation Marks	End Semester Examination Duration
150	50	100	3 Hours

Continuous Internal Evaluation Pattern:

Attendance	10 Marks
Continuous Assessment Tests (2 numbers)	25 Marks
Assignment/Quiz/Course project	15 Marks

End Semester Examination Pattern:

There will be two parts; Part A and Part B. Part A contain 10 questions with 2 questions from each module, having 3 marks for each question. Students should answer all questions. Part B contains 2 questions from each module of which student should answer any one. Each question can have maximum 2 sub-divisions and carry 14 marks.



Course Code	Course Name	Category	L	T	P	Credit	Year of Introduction
EC0M20C	INTRODUCTION TO SIGNALS AND SYSTEMS	MINOR (Basket-3)	3	1	0	4	2020

i) COURSE OVERVIEW

The course aims to introduce various type of signals and systems in analog and discrete domain. It gives an insight into the properties and analysis of convolution integral and sum. It also deals with the frequency analysis of signals using fourier transform and introducing sampling theorem.

ii) COURSE OUTCOMES

After the completion of the course, the student will be able to:

Course Outcomes	Description	Level
CO 1	Explain the concepts of Signals and Systems	Understand
CO 2	Apply properties and operations of signals and systems .	Apply
CO 3	Apply various transform techniques for analysing a signal in frequency domain	Apply
CO 4	Apply convolution for finding the response and transfer function of a system	Apply
CO 5	Describe correlation of discrete time signals	Understand
CO 6	Apply sampling theorem to discretize and analyse continuous time signals	Apply

iii) SYLLABUS

Introduction to continuous time signals: Definition of signal. Basic continuous-time signals. Frequency and angular frequency of continuous-time signals. Basic operation on signals. Classification of continuous-time signals: Periodic and Non-periodic signals. Even and Odd signals, Energy and power signals. Noise and Vibration signals.

Discrete time signals: Basic discrete-time signals. Frequency and angular frequency of discrete-time signals. Classification of discrete-time signals: Periodic and Non-periodic signals. Even and Odd signals, Energy and power signals.

Systems: System definition. Continuous-time and discrete-time systems. Properties – Linearity, Time invariance, Causality, Invertibility, Stability. Representation of systems using impulse response.

Linear time invariant systems: LTI system definition. Response of a continuous-time LTI system and the Convolutional Integral. Properties. Response of a discrete-time LTI system and the Convolutional Sum. Properties. Correlation of discrete-time signals.

Frequency Analysis of Signals: Concept of frequency in continuous-time and discrete-time signals. Fourier transforms of continuous-time and discrete-time signals. Parseval's theorem.



Interpretation of Spectra. Case study of a vibration signal. Sampling theorem – perfect reconstruction of sampled signal.

iv) (a) TEXT BOOKS

- 1) Simon Haykin, Barry Van Veen, “Signals and systems”, John Wiley, 2/e, 2007.
- 2) Hwei P Hsu, “Theory and problems of signals and systems”, Schaum Outline Series, MGH, 1995.
- 3) Anders Brandt, “Noise and Vibration Analysis - Signal Analysis and Experimental Procedures”, Wiley publication, 1/e, 2011.

(b) REFERENCES

- 1) Anand Kumar, “Signals and Systems”, PHI, 3/e, 2013.
- 2) P Ramesh Babu, R. Ananda Natarajan, “Signals and Systems”, 5/e, 2019.
- 3) Sanjay Sharma, “Signals and Systems”, Kindle edition, 1/e, 2020.

v) COURSE PLAN

Module	Contents	No. of hours
I	Introduction to continuous time signals: Definition of signal. Basic continuous-time signals. Frequency and angular frequency of continuous-time signals. Basic operation on signals. Classification of continuous-time signals: Periodic and Non-periodic signals. Even and Odd signals, Energy and power signals. Noise and Vibration signals	12
II	Discrete time signals: Basic discrete-time signals. Frequency and angular frequency of discrete-time signals. Classification of discrete-time signals: Periodic and Non-periodic signals. Even and Odd signals, Energy and power signals.	12
III	Systems: System definition. Continuous-time and discrete-time systems. Properties – Linearity, Time invariance, Causality, Invertibility, Stability. Representation of systems using impulse response	12
IV	Linear time invariant systems: LTI system definition. Response of a continuous-time LTI system and the Convolutional Integral. Properties. Response of a discrete-time LTI system and the Convolutional Sum. Properties. Correlation of discrete-time signals	10
V	Frequency Analysis of Signals: Concept of frequency in continuous-time and discrete-time signals. Fourier transforms of continuous-time and discrete-time signals. Parseval’s theorem. Interpretation of Spectra. Case study of a vibration signal. Sampling theorem – perfect reconstruction of sampled signal.	14
	Total hours	60

**vi) ASSESSMENT PATTERN****Mark distribution**

Total Marks	Continuous Internal Evaluation Marks	End Semester Evaluation Marks	End Semester Examination Duration
150	50	100	3 Hours

Continuous Internal Evaluation Pattern:

Attendance	10 Marks
Continuous Assessment Tests (2 numbers)	25 Marks
Assignment/Quiz/Course project	15 Marks

End Semester Examination Pattern:

There will be two parts; Part A and Part B. Part A contain 10 questions with 2 questions from each module, having 3 marks for each question. Students should answer all questions. Part B contains 2 questions from each module of which student should answer any one. Each question can have maximum 2 sub-divisions and carry 14 marks.



SEMESTER IV



Course Code	Course Name	Category	L	T	P	Credit	Year of Introduction
MA0U20C	PROBABILITY, RANDOM PROCESS AND NUMERICAL METHODS	BSC	3	1	0	4	2020

i) COURSE OVERVIEW

This course introduces students to the modern theory of probability and statistics, covering important models of random variables and analysis of random processes using appropriate time and frequency domain tools. A brief course in numerical methods familiarises students with some basic numerical techniques for finding roots of equations, evaluating definite integrals solving systems of linear equations and solving ordinary differential equations which are especially useful when analytical solutions are hard to find.

ii) COURSE OUTCOMES

After the completion of the course, the student will be able to:

Course Outcomes	Description	Level
CO 1	Identify the different discrete random experiments and find the probabilities of their occurrence	Apply
CO 2	Identify the different continuous random experiments and find the probabilities of their occurrence	Apply
CO 3	Examine random processes using autocorrelation, power spectrum and Poisson process model as appropriate.	Apply
CO 4	Find roots of equations, definite integrals and interpolating polynomial on given numerical data using standard numerical techniques	Apply
CO 5	Apply standard numerical techniques for solving systems of equations, fitting curves on given numerical data and solving ordinary differential equations.	Apply

iii) SYLLABUS

Discrete random variables and their probability distributions, Binomial distribution, Poisson distribution, Discrete bivariate distributions, Expectation -multiple random variables.

Continuous random variables and their probability distributions-Uniform, exponential and normal distributions, Continuous bivariate distributions, Expectation-multiple random variables, i.i.d random variables and Central limit theorem.

Random processes and its classification, wide sense stationary (WSS) processes, power spectral density of WSS processes, Poisson process.

Roots of equations- Newton-Raphson, regula falsi methods. Interpolation-finite differences, Newton's forward and backward formula, Newton's divided difference method, Lagrange's method. Numerical integration.



Solution of linear systems-Gauss-Siedal and Jacobi iteration methods. Curve fitting-method of least squares, Solution of ordinary differential equations-Euler and Classical Runge-Kutta method of second and fourth order, Adams- Moulton predictor-correction method

iv) (a) TEXT BOOKS

- 1) Jay L. Devore, Probability and Statistics for Engineering and the Sciences, 8th edition, Cengage, 2012
- 2) Oliver C. Ibe, Fundamentals of Applied Probability and Random Processes, Elsevier, 2005.
- 3) Erwin Kreyszig, Advanced Engineering Mathematics, 10 th Edition, John Wiley & Sons, 2016.

(b) REFERENCES

- 1) Hossein Pishro-Nik, Introduction to Probability, Statistics and Random Processes, Kappa Research, 2014 (Also available online at www.probabilitycourse.com)
- 2) V.Sundarapandian, Probability, Statistics and Queueing theory, PHI Learning, 2009
- 3) Gubner, Probability and Random Processes for Electrical and Computer Engineers, Cambridge University Press, 2006.
- 4) B.S. Grewal, Higher Engineering Mathematics, Khanna Publishers, 36 Edition, 2010.

v) COURSE PLAN

Module	Contents	No. of hours
I	Discrete random variables and probability distributions, expected value, mean and variance (discrete). Binomial distribution-mean, variance, Poisson distribution-mean, variance, Poisson approximation to binomial. Discrete bivariate distributions, marginal distributions, Independence of random variables (discrete), Expected values	12
II	Continuous random variables and probability distributions, expected value, mean and variance (continuous) Uniform, exponential and normal distributions, mean and variance of these distributions Continuous bivariate distributions, marginal distributions, Independent random variables, Expected values, Central limit theorem.	12
III	Random process -definition and classification, mean , autocorrelation, WSS processes its autocorrelation function and properties. Power spectral density .Poisson process, inter-distribution of arrival time. combination of independent Poisson processes(merging) and subdivision (splitting) of Poisson processes	12



IV	Errors in numerical computation-round-off, truncation and relative error, Solution of equations – Newton-Raphson method and Regula-Falsi method. Interpolation-finite differences, Numerical integration-Trapezoidal rule and Simpson’s 1/3rd rule (Proof or derivation of the formulae not required for any of the methods in this module)	12
V	Solution of linear systems-Gauss-Siedal method, Jacobi iteration method Curve-fitting-fitting straight lines and parabolas to pairs of data points using method of least squares Solution of ODE-Euler and Classical Runge - Kutta methods of second and fourth order ,Adams-Moulton predictor-corrector methods	12
	Total hours	60

vi) ASSESSMENT PATTERN

Mark distribution

Total Marks	Continuous Internal Evaluation Marks	End Semester Evaluation Marks	End Semester Examination Duration
150	50	100	3 Hours

Continuous Internal Evaluation Pattern:

Attendance	10 Marks
Continuous Assessment Tests (2 numbers)	25 Marks
Assignment/Quiz/Course project	15 Marks

End Semester Examination Pattern:

There will be two parts; Part A and Part B. Part A contain 10 questions with 2 questions from each module, having 3 marks for each question. Students should answer all questions. Part B contains 2 questions from each module of which student should answer any one. Each question can have maximum 2 sub-divisions and carry 14 marks.



Course Code	Course Name	Category	L	T	P	Credit	Year of Introduction
EC1U20D	ANALOG CIRCUITS	PCC	3	1	0	4	2020

i) **PREREQUISITE:** ES0U10D Basics of Electrical and Electronics Engineering

ii) **COURSE OVERVIEW**

To develop the skill of analysis and design of various analog circuits using discrete electronic components and devices.

iii) **COURSE OUTCOMES**

After the completion of the course the student will be able to:

Course Outcomes	Description	Level
CO 1	Design various RC circuits, Clipping, Clamping and biasing circuits.	Apply
CO 2	Analyse CE amplifier in low, mid and high frequency ranges.	Analyze
CO 3	Analyse biasing techniques of MOSFET, CS amplifier and Multistage amplifiers.	Analyze
CO 4	Analyse various Feedback amplifiers and an Oscillator	Analyze
CO 5	Explain the Principle of operation of Oscillators, Power amplifiers and transistor-based linear regulated power supplies	Understand

iv) **SYLLABUS**

Wave Shaping circuits- Differentiator, Integrator, First Order High pass and low pass RC circuits, Diode clipping and clamping circuits. Transistor biasing circuits.

Analysis of BJT Amplifier circuits- Small signal analysis of CE configuration, high frequency analysis of BJT CE amplifier.

Amplifiers - MOSFET amplifiers- Small signal analysis of CS configuration, Multistage Amplifiers – Cascade and Cascode, Feedback amplifiers, Power amplifiers.

Oscillators – Low frequency and High frequency, Regulated power supplies- Shunt, Series, Short circuit protection, fold back protection and current boosting.

v) (a) **TEXT BOOKS**

- 1) Sedra A. S. and K. C. Smith, Microelectronic Circuits, 6/e, Oxford University Press, 2013
- 2) Millman J. and C. Halkias, Integrated Electronics, 2/e, McGraw-Hill, 2010
- 3) Robert Boylestad and L Nashelsky, Electronic Devices and Circuit Theory, 11/e Pearson, 2015

(b) **REFERENCES**

- 1) Neamen D., Electronic Circuits – Analysis and Design, 3/e, TMH, 2007
- 2) Razavi B., Fundamentals of Microelectronics, Wiley, 2015
- 3) Rashid M. H., Microelectronic Circuits – Analysis and Design, Cengage Learning, 2/e, 2011
- 4) David A Bell, “Electronic Devices and Circuits”, Oxford University Press, 2008.



vi) COURSE PLAN

Module	Contents	No. of hours
I	<p>Wave shaping circuits: First order RC differentiating and integrating circuits, First order RC low pass and high pass filters.</p> <p>Diode Clipping circuits – Positive, negative and biased clipper.</p> <p>Diode Clamping circuits – Positive, negative and biased clamper.</p> <p>Transistor biasing: Need, operating point, concept of DC load line, fixed bias, self-bias, voltage divider bias, bias stabilization.</p>	12
II	<p>BJT Amplifiers: Classification of amplifiers, RC coupled amplifier (CE configuration) – need of various components and design, Concept of AC load lines.</p> <p>Small signal analysis of CE configuration using small signal hybrid-pi model for mid frequency. (gain, input and output impedance).</p> <p>High frequency equivalent circuits of BJT, Miller effect, Analysis of high frequency response of CE amplifier, voltage gain and frequency response</p>	12
III	<p>MOSFET amplifiers: MOSFET circuits at DC, MOSFET as an amplifier, Biasing of discrete MOSFET amplifier, Small signal equivalent circuit. Small signal voltage and current gain, input and output impedances of CS configuration. CS stage with current source load, CS stage with diode-connected load.</p> <p>Multistage amplifiers – effect of cascading on gain and bandwidth. Cascode amplifier.</p>	11
IV	<p>Feedback amplifiers: Properties of positive and negative feedback on gain, frequency response and distortion. Analysis of the four basic feedback topologies, Analysis of discrete circuits in each feedback topologies –voltage gain, input and output impedance.</p> <p>Oscillators: Classification, criterion for oscillation, Wien bridge oscillator, Hartley and Crystal oscillator. (working principle and design equations of the circuits; analysis of Wien bridge oscillator only required)</p>	13
V	<p>Power amplifiers: Classification, Transformer coupled class A power amplifier, push pull class B and class AB power amplifiers, complementary-symmetry class B and Class AB power amplifiers, efficiency and distortion (no analysis required)</p> <p>Linear Regulated power supplies: Principle of Linear Regulated power supplies, Shunt voltage regulator, series voltage regulator, Short circuit protection and fold back protection, Output current boosting.</p>	12
	Total hours	60

**vii) ASSESSMENT PATTERN****Mark distribution**

Total Marks	Continuous Internal Evaluation Marks	End Semester Evaluation Marks	End Semester Examination Duration
150	50	100	3 Hours

Continuous Internal Evaluation Pattern:

Attendance	10 Marks
Continuous Assessment Tests (2 numbers)	25 Marks
Assignment/Quiz/Course project <i>Atleast one assignment should be simulation of one type transistor amplifier on any circuit simulation software.</i>	15 Marks

End Semester Examination Pattern:

There will be two parts; Part A and Part B. Part A contain 10 questions with 2 questions from each module, having 3 marks for each question. Students should answer all questions. Part B contains 2 questions from each module of which student should answer any one. Each question can have maximum 2 sub-divisions and carry 14 marks.



Course Code	Course Name	Category	L	T	P	Credit	Year of Introduction
EC1U20E	SIGNALS AND SYSTEMS	PCC	3	1	0	4	2020

i) COURSE OVERVIEW

This course aims to lay the foundational aspects of signals and systems in both continuous time and discrete time, in preparation for more advanced subjects in digital signal processing, image processing, communication theory and control systems.

ii) COURSE OUTCOMES

After the completion of the course, the student will be able to:

Course Outcomes	Description	Level
CO 1	Explain the concepts of Signals and Systems	Understand
CO 2	Apply properties of signals and systems to classify them	Apply
CO 3	Apply various transform techniques for representing a signal in frequency domain	Apply
CO 4	Apply convolution for finding the response and transfer function of a system.	Apply
CO 5	Describe correlation and orthogonality of signals	Understand
CO 6	Apply sampling theorem to discretize and analyse continuous time signals	Apply

iii) SYLLABUS

Elementary signals, Continuous time and Discrete time signals and systems, Signal operations, Differential equation representation, Difference equation representation, Continuous time LTI Systems, Discrete time LTI Systems, Correlation between signals, Orthogonality of signals, Frequency domain representation, Continuous time Fourier series, Continuous time Fourier transform, Using Laplace transform to characterize Transfer function, Stability and Causality using ROC of Transfer transform, Frequency response, Sampling, Aliasing, Z transform, Inverse Z transform, Unilateral Z-transform, Frequency domain representation of discrete time signals, Discrete time Fourier series and discrete time

iv) (a) TEXT BOOKS

- 1) Alan V. Oppenheim and Alan Willsky, Signals and Systems, PHI, 2/e, 2018
- 2) Simon Haykin, Signals & Systems, John Wiley, 2/e, 2003

**(b) REFERENCES**

- 1) Anand Kumar, Signals and Systems, PHI, 3/e, 2013.
- 2) Mahmood Nahvi, Signals and System, Mc Graw Hill (India), 2015.
- 3) P Ramesh Babu, R Anandanatarajan, Signals and System, 4th Ed, 2014
- 4) Rodger E. Ziemer, Signals & Systems - Continuous and Discrete, Pearson, 4/e, 2013

v) COURSE PLAN

Module	Contents	No. of hours
I	Elementary Signals, Classification and representation of continuous time and discrete time signals, Signal operations. Continuous time and discrete time systems – Classification, Properties. Representation of systems: Differential equation representation of continuous time systems. Difference equation representation of discrete systems. Continuous time LTI systems and convolution integral Discrete time LTI systems and linear convolution. Stability and causality of LTI systems. Correlation between signals, Orthogonality of signals.	16
II	Frequency domain representation of continuous time signals - continuous time Fourier series and its properties. Continuous time Fourier transform and its properties. Convergence and Gibbs phenomenon Review of Laplace Transform, ROC of Transfer function, Properties of ROC, Stability and causality conditions. Relation between Fourier and Laplace transforms.	14
III	Analysis of LTI systems using Laplace and Fourier transforms. Concept of transfer function, Frequency response, Magnitude and phase response. Sampling of continuous time signals, Sampling theorem for lowpass signals, aliasing.	10
IV	Frequency domain representation of discrete time signals, Discrete time Fourier series for discrete periodic signals. Properties of DTFS. Discrete time Fourier transform (DTFT) and its properties. Analysis of discrete time LTI systems using DTFT. Magnitude and phase response.	10
V	Z transform, ROC, Inverse transform, properties, Unilateral Z transform. Relation between DTFT and Z-Transform, Analysis of discrete time LTI systems using Z transform, Transfer function. Stability and causality using Z transform.	10
	Total hours	60



Simulation Assignments

The following simulations to be done in Scilab/ Matlab/ LabView/GNU Octave:

1. Generate basic discrete time signals
2. Generate linear convolution
3. Generate different signals as combinations of basic signals
4. Write a function for simulating DTFT of a signal.
5. Realize an LTI system with a given system response

vi) ASSESSMENT PATTERN

Mark distribution

Total Marks	Continuous Internal Evaluation Marks	End Semester Evaluation Marks	End Semester Examination Duration
150	50	100	3 Hours

Continuous Internal Evaluation Pattern:

Attendance	10 Marks
Continuous Assessment Tests (2 numbers)	25 Marks
Assignment/Quiz/Course project	15 Marks

End Semester Examination Pattern:

There will be two parts; Part A and Part B. Part A contain 10 questions with 2 questions from each module, having 3 marks for each question. Students should answer all questions. Part B contains 2 questions from each module of which student should answer any one. Each question can have maximum 2 sub-divisions and carry 14 marks.



Course Code	Course Name	Category	L	T	P	Credit	Year of Introduction
EC1U20F	COMPUTER ARCHITECTURE AND MICROCONTROLLERS	PCC	3	1	0	4	2020

i) **PREREQUISITE:** ES0U10E - Programming in C, EC1U20B - Logic Circuit Design

ii) COURSE OVERVIEW

This course aims to introduce the architectures of computers and microcontrollers. It gives an insight into programming using assembly language and interfacing of 8051 microcontroller with peripheral devices.

iii) COURSE OUTCOMES

After the completion of the course, the student will be able to:

Course Outcomes	Description	Level
CO 1	Explain the functional units, I/O and memory management of a typical computer.	Understand
CO 2	Explain the architecture of 8051 and ARM microcontrollers.	Understand
CO 3	Apply the knowledge of addressing modes and instructions to develop assembly language programs for 8051 microcontrollers.	Apply
CO 4	Interface 8051 microcontrollers with various peripheral devices.	Apply
CO 5	Explain memory hierarchy and different I/O accessing techniques used in computer systems.	Understand

iv) SYLLABUS

Computer Arithmetic and Processor Basics:

Algorithms for binary multiplication and division. Fixed and floating point number representation. Functional units of a computer, Von Neumann and Harvard computer architectures, CISC and RISC architectures. Processor Architecture – General internal architecture, Address bus, Data bus, control bus. Register set – status register, accumulator, program counter, stack pointer, general purpose registers. Processor operation – instruction cycle, instruction fetch, instruction decode, instruction execute, timing response, instruction sequencing and execution (basic concepts, datapath).

8051 Architecture:

Microcontrollers and Embedded Processors. Architecture – Block diagram of 8051, Pin configuration, Registers, Internal Memory, Timers, Port Structures, Interrupts, Assembly Language Programming - Addressing Modes, Instruction set (Detailed study of 8051 instruction set is required).

Programming and Interfacing of 8051:

Simple programming examples in assembly language, interfacing with 8051 using Assembly language programming: LED, Seven segment LED display. Programming in C – Declaring variables, Simple examples – delay generation, port programming, code conversion.



Interfacing of – LCD display, Keyboard, Stepper Motor, DAC and ADC -- with 8051 and its programming.

Advanced Concepts:

8051 Timers/Counters - Modes and Applications. Serial Data Transfer – SFRs of serial port, working, Programming the 8051 to transfer data serially. Introduction to ARM – ARM family, ARM 7 register architecture. ARM programmer’s model. System software - Assembler, Interpreter, Compiler, Linker, Loader, Debugger.

The Memory System:

Types of memory - RAM, ROM. Memory Characteristics and Hierarchy. Cache memory – The basics of Caches, Mapping techniques, Improving Cache performance. Virtual memory – Overlay, Memory management, Address translation- Input/Output Organization – Introduction, Synchronous vs. asynchronous I/O, Programmed I/O, Interrupt driven I/O, Direct Memory Access.

v) a) TEXT BOOKS

- 1) M.A.Mazidi, J. G. Mazidi and R. D. McKinlay, *The 8051 Microcontroller and Embedded Systems: Using Assembly and C*, Pearson Education, Second edition, 2011.
- 2) Stallings W., *Computer Organisation and Architecture*, 10/e, Pearson Education, 2018
- 3) Steve Furber, *ARM System - on-chip Architecture*, Pearson Education, 2/e, 2001

b) REFERENCES

- 1) David A. Patterson, John L. Hennessy, *Computer organization and design: The Hardware/Software interface*, Morgan Kaufmann Publishers, 5/e, 2014.
- 2) Subrata Ghoshal, *Computer Architecture and Organization: From 8085 to Core2Duo and beyond*, Pearson, 1/e, 2011.
- 3) V. Carl Hamacher, Zvonko G. Vranesic, Safwat G.Zaky ,*Computer Organisation*, Mc GrawHill Education, 5/e, 2001.

vi) COURSE PLAN

Module	Contents	No. of hours
I	Algorithms for binary multiplication and division. Fixed and floating point number representation. Functional units of a computer, Von Neumann and Harvard computer architectures, CISC and RISC architectures. Processor Architecture – General internal architecture, Address bus, Data bus, control bus. Register set – status register, accumulator, program counter, stack pointer, general purpose registers. Processor operation – instruction cycle, instruction fetch, instruction decode, instruction execute, timing response, instruction sequencing and execution (basic concepts, datapath).	12



II	Microcontrollers and Embedded Processors. Architecture – Block diagram of 8051, Pin configuration, Registers, Internal Memory, Timers, Port Structures, Interrupts. Assembly Language Programming - Addressing Modes, Instruction set (Detailed study of 8051 instruction set is required).	12
III	Simple programming examples in assembly language. Interfacing with 8051 using Assembly language programming: LED, Seven segment LED display. Programming in C – Declaring variables, Simple examples – delay generation, port programming, code conversion. Interfacing of – LCD display, Keyboard, Stepper Motor, DAC and ADC -- with 8051 and its programming.	12
IV	8051 Timers/Counters - Modes and Applications. Serial Data Transfer – SFRs of serial port, working, Programming the 8051 to transfer data serially. Introduction to ARM – ARM family, ARM 7 register architecture. ARM programmer’s model. System software - Assembler, Interpreter, Compiler, Linker, Loader, Debugger.	12
V	Types of memory - RAM, ROM. Memory Characteristics and Hierarchy. Cache memory – The basics of Caches, Mapping techniques, Improving Cache performance. Virtual memory – Overlay, Memory management, Address translation. Input/Output Organization – Introduction, Synchronous vs. asynchronous I/O, Programmed I/O, Interrupt driven I/O, Direct Memory Access.	12
	Total hours	60

vii) ASSESSMENT PATTERN**viii) Mark distribution**

Total Marks	Continuous Internal Evaluation Marks	End Semester Evaluation Marks	End Semester Examination Duration
150	50	100	3 Hours

Continuous Internal Evaluation Pattern:

Attendance	10 Marks
Continuous Assessment Tests (2 numbers)	25 Marks
Assignment/Quiz/Course project	15 Marks



It is mandatory that a *course project* shall be undertaken by a student for this subject. The course project must be performed as a hardware realization of a typical embedded system using Embedded C/ Assembly Language Programming. Instead of two assignments, two evaluations will be performed on the course project along with continuous assessment tests, each carrying 5 marks. Upon successful completion of the project, a brief report must be submitted by the student which will be evaluated for 5 marks.

End Semester Examination Pattern:

There will be two parts; Part A and Part B. Part A contain 10 questions with 2 questions from each module, having 3 marks for each question. Students should answer all questions. Part B contains 2 questions from each module of which student should answer any one. Each question can have maximum 2 sub-divisions and carry 14 marks.



Course Code	Course Name	Category	L	T	P	Credit	Year of Introduction
ESOU20A	DESIGN AND ENGINEERING	ESC	2	0	0	2	2020

i) **PREREQUISITE:** Nil. It's generic to all engineering disciplines.

ii) **COURSE OVERVIEW**

Goal of this course is to expose the students to the fundamental principles of design engineering. Students are expected to apply design thinking in learning, which is very important and relevant for today. The course also focuses on familiarizing the students with the aesthetics, ergonomics and sustainability factors in designs and practice professional ethics while designing.

iii) **COURSE OUTCOMES**

After the completion of the course, the student will be able to:

Course Outcomes	Description	Level
CO 1	Demonstrate the different stages involved in design engineering process	Understand
CO 2	Compose a problem statement with design objectives taking into account the customer requirements, design constraints and functionality.	Create
CO 3	Develop innovative solutions to the Design problem through brainstorming and ideation.	Apply
CO 4	Identify the concepts of Biomimicry, Aesthetics and Ergonomic factors in designs to add more value to it.	Apply
CO 5	Apply the Design communication tools to model an idea.	Apply
CO6	Incorporate different segments of knowledge in engineering in order to develop innovative, reliable, sustainable and economically viable designs.	Apply

iv) **SYLLABUS**

Introduction to engineering design. Generate a design through the Design Process stages.

Design Thinking Approach, Design Thinking Process Stages: Empathize, Define, Ideate, Prototype and Test. Design Thinking as Divergent-Convergent Questioning.

Ideation in Design Thinking - Brainstorming sessions. Design Engineering Concepts. Application of Biomimicry, Aesthetics and Ergonomics in Design. Design for X – Quality, Reliability and Sustainability

Design Communication, Data Representation, Communicating Designs Orally, Graphically and in Writing. Modelling, Prototyping and Proof of Concept.



Value Engineering, Concurrent and Reverse Engineering. Expediency, Economics and Environment in Design Engineering. Design Rights. Ethics in Design.

v) (a) TEXT BOOKS

- 1) Yousef Haik, Sangarappillai Sivaloganathan, Tamer M. Shahin, *Engineering Design Process*, Third Edition, Cengage Learning, (1 January 2017)
- 2) Linda C. Schmidt , George Dieter, *Engineering Design*, McGraw Hill Education; Fourth edition (1 July 2017)
- 3) Pavan Soni, *Design Your Thinking: The Mindsets, Toolsets and Skill Sets for Creative Problem-Solving*, Penguin Random House India Private Limited, 2020
- 4) Voland, G., *Engineering by Design*, Pearson India 2014, Second Edition, ISBN 9332535051

(b) REFERENCES

- 1) Clive L Dym, *Engineering Design: A Project Based Introduction*, Fourth Edition, John Wiley & Sons, New York 2009.
- 2) Tim Brown, *Change by Design: How Design Thinking Transforms Organizations and Inspires Innovation*, Harper Business; Revised, Updated ed. edition (5 March 2019)
- 3) Don Norman , *The Design of Everyday Things*, Basic Books; 2 edition (5 November 2013)
- 4) Dominique Forest , *Art of Things: Product Design Since 1945*, Abbeville Press Inc.,U.S.; Special edition (16 October 2014)
- 5) Javier Abarca, Al Bedard, et al, *Introductory Engineering Design – A Projects-Based Approach*, 3rd ed, Regents of the University of Colorado, 2000.
- 6) Nigel Cross, *Design Thinking: Understanding How Designers Think and Work*, Berg Publishers 2011, First Edition, ISBN: 978-1847886361
- 7) Pahl, G., Beitz, W., Feldhusen, J., Grote, K.-H., *Engineering Design: A Systematic Approach*, Springer 2007, Third Edition, ISBN 978-1-84628-319-2.
- 8) George Dieter , *Engineering Design: A Materials and Processing Approach*, McGraw-Hill Education / Asia; 3 edition (16 February 2000)

vi) COURSE PLAN

Module	Contents	No. of hours
I	Design Process: - Defining a Design Process:- Detailing Customer Requirements, Setting Design Objectives, Identifying Constraints, Establishing Functions, Generating Design Alternatives and Choosing a Design.	3
	<i>Practical Exercise: Need Identification. How to define a Problem Statement. Present an idea using the stages of the Design Process.</i>	3
II	Design Thinking Approach: -Introduction to Design Thinking, Iterative Design Thinking Process Stages: Empathize, Define, Ideate, Prototype and Test. Design Thinking as Divergent-Convergent Questioning. Empathize – User Persona, Day in the Life Technique, identify	4



	customer requirements using Morphological Chart and set design objectives. Define - Identifying and formulating a Problem Statement -Fish Bone Diagram	
	<i>Practical Exercise: User Persona Chart. Morphological Chart</i>	2
III	Ideate - Brainstorming sessions, and ideation using Random word technique, SCAMPER. Design Engineering Concepts: Modular Design and Life Cycle Design Approaches. Application of Biomimicry, Aesthetics and Ergonomics in Design. Design for X – Quality, Reliability and Sustainability.	4
	<i>Practical Exercise: Brainstorming, 6-3-5 technique, Random Word Technique</i>	2
IV	Design Communication: - Data Representation, Communicating Designs Orally, Graphically and in Writing. Modelling, Prototyping and Proof of Concept. Awareness of Basic tools of Design like – Autodesk, CATIA, MATLAB	3
	<i>Practical Exercise: Communicating Designs Graphically.</i>	4
V	Value Engineering, Concurrent Engineering, and Reverse Engineering in Design. Expediency, Economics and Environment in Design Engineering: - Design for Production, Use, and Sustainability. Engineering Economics in Design. Design Rights. Ethics in Design	3
	<i>Practical Exercise: Case Studies</i>	2
	Total hours	30

**vii) ASSESSMENT PATTERN****Mark distribution**

Total Marks	Continuous Internal Evaluation Marks	End Semester Evaluation Marks	End Semester Examination Duration
150	50	100	3 Hours

Continuous Internal Evaluation Pattern:

Attendance	10 Marks
Continuous Assessment Tests (2 numbers)	25 Marks
Assignment/Quiz/Course project	15 Marks

End Semester Examination Pattern:

There will be two parts; Part A and Part B. Part A: 30 marks and part B : 70 marks. Part A contains 10 questions with 2 questions from each module, having 3 marks for each question. Students should answer all questions. Part B contains 2 case study questions from each module of which student should answer any one. Each question carry 14 marks and can have maximum 2 sub questions.



Course Code	Course Name	Category	L	T	P	Credit	Year of Introduction
NC0U20B	CONSTITUTION OF INDIA	MNC	2	0	0	---	2020

i) COURSE OVERVIEW:

The study of the Constitution of India enables the students to

- 1) Understand the fundamental rights & duties and directive principles
- 2) Understand the functions of Executive, Legislature and Judiciary of the Union and the States
- 3) Understand the relation between the Union and the States
- 4) Provides the student the knowledge and strength to face the society and people.

ii) COURSE OUTCOMES:

After the completion of the course, the student will be able to:

Course Outcomes	Description	Level
CO 1	Explain the historical background of the constitution of India and its features.	Understand
CO 2	Describe the fundamental rights, duties and directive principles of state policy.	Understand
CO 3	Discuss the machinery of executive, legislature and judiciary of the Union and the States.	Understand
CO4	Explain the relation between the Union and the States.	Understand

iii) SYLLABUS

Constitution of India: Definition, historical background, features, preamble, territory, citizenship. State, fundamental rights, directive Principles, fundamental duties. The machinery of the union government, machinery of the state governments. Statutory institutions, miscellaneous provisions, amendments to constitution.

iv)(a) TEXT BOOKS

- 1) M. Laxmikanth, Indian Polity, McGraw Hill Education India, 6/e, 2019.
- 2) D. D. Basu, Introduction to the Constitution of India, Lexis Nexis, New Delhi, 24/e, 2019.
- 3) P. M. Bhakshi, The Constitution of India, Universal Law, 14/e, 2017.

(b) REFERENCES

- 1) Ministry of Law and Justice, The Constitution of India, Govt. of India, New Delhi, 2019.
- 2) J. N. Pandey, The Constitutional Law of India, Central Law agency, Allahabad, 51/e, 2019.
- 3) M. V.Pylee, India's Constitution, S. Chand and Company, New Delhi, 16/e, 2016.

**v) COURSE PLAN**

Module	Contents	No. of hours
I	Definition of constitution, historical background, salient features of the constitution. Preamble of the constitution, union and its territory. Meaning of citizenship, types, termination of citizenship.	4
II	Definition of state, fundamental rights, general nature, classification, right to equality, right to freedom, right against exploitation. Right to freedom of religion, cultural and educational rights, right to constitutional remedies. Protection in respect of conviction for offences. Directive principles of state policy, classification of directives, fundamental duties.	7
III	The Union Executive, the President, the Vice President, the Council of Ministers, the Prime Minister, Attorney-General, functions. The parliament, composition, Rajya sabha, Lok sabha, qualification and disqualification of membership, functions of parliament. Union judiciary, the supreme court, jurisdiction, appeal by special leave.	7
IV	The State executive, the Governor, the council of ministers, the Chief minister, advocate general, union Territories. The State Legislature, composition, qualification and disqualification of membership, functions. The state judiciary, the high court, jurisdiction, writs jurisdiction.	6
V	Relations between the Union and the States, legislative relation, administrative relation, financial Relations, Inter State council, finance commission. Emergency provision, freedom of trade commerce and inter course, comptroller and auditor general of India, public Services, public service commission, administrative Tribunals. Official language, elections, special provisions relating to certain classes, amendments to constitution.	6
	Total hours	30

**vi) ASSESSMENT PATTERN****Mark distribution**

Total Marks	Continuous Internal Evaluation Marks	End Semester Evaluation Marks	End Semester Examination Duration
150	50	100	3 Hours

Continuous Internal Evaluation Pattern:

Attendance	10 Marks
Continuous Assessment Tests (2 numbers)	25 Marks
Assignment/Quiz/Course project	15 Marks

End Semester Examination Pattern:

There will be two parts; Part A and Part B. Part A contain 10 questions with 2 questions from each module, having 3 marks for each question. Students should answer all questions. Part B contains 2 questions from each module of which student should answer any one. Each question can have maximum 2 sub-divisions and carry 14 marks.



Course Code	Course Name	Category	L	T	P	Credit	Year of Introduction
EC1U28C	ANALOG CIRCUITS AND SIMULATION LAB	PCC	0	0	3	2	2020

i) COURSE OVERVIEW

Objective of this course is to familiarize the students with the Analog Circuits Design through the implementation of basic Analog Circuits using discrete components and simulation of basic Analog Circuits.

ii) COURSE OUTCOMES

After the completion of the course, the student will be able to:

Course Outcomes	Description	Level
CO 1	Implement the basic analog circuits using discrete components.	Analyze
CO 2	Simulate analog circuits using EDA tools.	Analyze

iii) SYLLABUS

Experiments using Discrete components

RC integrating and differentiating circuits, Clipping and clamping circuits, RC coupled CE amplifier, Cascade amplifier, Low frequency oscillator, Transistor series voltage regulator.

Simulation Experiments

RC integrating and differentiating circuits, Clipping and clamping circuits, MOSFET amplifier, Cascode amplifier, Feedback amplifiers, Power amplifiers

iv) REFERENCES

- 1) Navas K A, Electronics Lab Manual, Volume 1, PHI Learning Private Limited, 5th Edition, 2015.

v) COURSE PLAN

Experiment No.	Part A List of experiments using discrete components	No. of hours
I	RC integrating and differentiating circuits (Transient analysis with different inputs and frequency response)	4
II	Clipping and clamping circuits (Transients and transfer characteristics)	4
III	RC coupled CE amplifier - frequency response characteristics	4
IV	Cascade amplifier – gain and frequency response	4
V	Low frequency oscillator –RC phase shift	4



VI	Transistor series voltage regulator (load and line regulation)	4
Part B:		
Simulation Experiments		
I	RC integrating and differentiating circuits (Transient analysis with different inputs and frequency response)	3
II	Clipping and clamping circuits (Transients and transfer characteristics)	3
III	MOSFET amplifier (CS) - frequency response characteristics	3
IV	Cascode amplifier -frequency response	4
V	Feedback amplifiers (current series, voltage series) - gain and	4
VI	Power amplifiers (transformer less) - Class B and Class AB frequency response	4
Total hours		45

vi) **ASSESSMENT PATTERN****Mark distribution**

Total Marks	Continuous Internal Evaluation Marks	End Semester Evaluation Marks	End Semester Examination Duration
150	75	75	3 Hours

Continuous Internal Evaluation Pattern:

Attendance	15 Marks
Continuous Assessment	30 Marks
Internal Test (Immediately before the II internal test)	30 Marks

End Semester Examination Pattern:

Preliminary work	15 marks
Implementing the work/Conducting the experiment	20 marks
Performance, result and inference (usage of equipment and troubleshooting):	15 marks
Viva voce	20 marks
Record	5 Marks



Course Code	Course Name	Category	L	T	P	Credit	Year of Introduction
EC1U28D	MICROCONTROLLER LAB	PCC	0	0	3	2	2020

i) **PREREQUISITE:** ES0U10E Programming in C

ii) **COURSE OVERVIEW:**

The objective of the course is to impart practical experience to students by exposing them to develop the Assembly Language/embedded C programming of Microcontrollers and to interface simple peripheral devices to a Microcontroller.

iii) **COURSE OUTCOMES**

After the completion of the course, the student will be able to:

Course Outcomes	Description	Level
CO 1	Develop assembly language programs/Embedded C programs for performing data manipulation.	Apply
CO 2	Develop assembly language programs/ C programs with IDE for microcontrollers.	Apply
CO 3	Develop assembly language programs to interface 8051 module with various peripheral modules	Apply

iv) **SYLLABUS**

Develop assembly language programs/Embedded C programs for performing data manipulation.

Develop the Interfacing of 8051 module with various peripheral modules.

v) **REFERENCES**

- 1) Muhammed Ali Mazidi & Janice Gilli Mazidi, R.D. Kinley, The 8051 microcontroller and Embedded System, Pearson Education, 2nd edition.
- 2) Steve Furber, ARM System - on-chip Architecture, Pearson Education, 2nd edition.

vi) **COURSE PLAN**

Experiment No.	List of exercises/experiments	No. of hours
	PART A: These experiments shall be performed using 8051 trainer kit. The programs shall be written either in embedded C or in assembly language.	
I	Addition and Subtraction of 16 bit data.	6
II	Sum of a series of 8 bit data.	3
III	Square ,cube , square root of 8 bit data.	6



IV	Data transfer/exchange between specified memory locations	3
V	Largest/smallest from a series	3
VI	Sorting (Ascending/Descending) of data.	3
VII	LCM and HCF of two 8 bit numbers.	3
VIII	Code conversion – Hex to Decimal/ASCII to Decimal and vice versa.	3
	Part B: Interfacing experiments shall be done using modern microcontrollers such as 8051 or ARM. The interfacing modules may be developed using Embedded C	
I	Display and keyboard interface with 8051/ARM.	3
II	ADC Interface with 8051/ARM.	3
III	DAC Interface with 8051/ARM.	3
IV	Stepper motor and DC motor interface.	3
V	Realization of Boolean expression through port	3
	Total hours	45

vii) ASSESSMENT PATTERN**Mark distribution**

Total Marks	Continuous Internal Evaluation Marks	End Semester Evaluation Marks	End Semester Examination Duration
150	75	75	3 Hours

Continuous Internal Evaluation Pattern:

Attendance	15 Marks
Continuous Assessment	30 Marks
Internal Test (Immediately before the II internal test)	30 Marks

End Semester Examination Pattern:

Preliminary work	15 marks
Implementing the work/Conducting the experiment	20 marks
Performance, result and inference (usage of equipment and troubleshooting):	15 marks
Viva voce	20 marks
Record	5 Marks



MINORS



Course Code	Course Name	Category	L	T	P	Credit	Year of Introduction
ECOM 20D	MICROCONTROLLERS	MINOR (Basket-1)	3	1	0	4	2020

i) COURSE OVERVIEW

This course aims to impart the overview of a microcontroller-based system design and interfacing techniques.

ii) COURSE OUTCOMES

After the completion of the course, the student will be able to:

Course Outcomes	Description	Level
CO 1	Explain the building blocks of a typical microcomputer/microcontroller system.	Understand
CO 2	Apply the knowledge of addressing modes and instructions to develop assembly language programs for 8051 microcontrollers.	Apply
CO 3	Interface the various peripheral devices to the 8051-microcontroller using assembly language program.	Apply
CO 4	Develop microcontroller-based applications using Open-Source Embedded Development boards.	Apply
CO 5	Explain the architecture of 8051, ATmega 2560 and ARM microcontrollers.	Understand

iii) SYLLABUS

Computer Arithmetic and Processor Basics: Functional units of a computer, Von Neumann and Harvard computer architectures, Processor Architecture – General internal architecture, Address bus, Data bus, control bus. Register set – status register, accumulator, program counter, stack pointer, general purpose registers. Processor operation – instruction cycle, instruction fetch, instruction decode, instruction execute.

8051 Architecture: Block diagram of 8051, Pin configuration, Registers, Internal Memory, Timers, Port Structures, Interrupts, Addressing Modes, Instruction set (brief study of 8051 instruction set).

Programming and Interfacing of 8051: Simple assembly language programs- addition, subtraction, multiplication, and division. Interfacing of LCD display, Keyboard, Stepper Motor, DAC, and ADC - with 8051 and its programming.

Open-Source Embedded Development Boards - Introduction to ATmega 2560 microcontroller - block diagram and pin description, Introduction to Arduino Mega 2560 board, Simple applications- Solar tracker, 4- digit 7 segment LED display, Tilt sensor, Home security alarm system, Digital Thermometer, IoT applications.

**ARM Based System:**

Introduction - ARM family, ARM 7 register architecture. ARM programmer's model.

Introduction to Raspberry pi 4 board, Applications- Portable Bluetooth speaker, remote controlled car, Photo Booth, IoT weather station, Home automation centre, Portal Digital eBook Library.

iv) a) TEXT BOOKS

- 1) Subrata Ghoshal, Computer Architecture and Organization: From 8085 to Core 2 Duo and beyond, Pearson, 2011.
- 2) M. A.Mazidi, J. G. Mazidi and R. D. McKinlay, "The 8051 Microcontroller and Embedded Systems: Using Assembly and C", Pearson Education, Second edition, 2011.
- 3) Steve Furber, ARM System - on-chip Architecture, Pearson Education, 2001.

c) REFERENCES

- 4) Stallings W., Computer Organisation and Architecture, 5/e, Pearson Education, 2019.
- 5) <https://www.microchip.com/wwwproducts/en/ATmega2560>
- 6) www.arduino.cc
- 7) www.raspberrypi.org

v) COURSE PLAN

Module	Contents	No. of hours
I	Computer Arithmetic and Processor Basics: Functional units of a computer, Von Neumann and Harvard computer architectures, Processor Architecture – General internal architecture, Address bus, Data bus, control bus. Register set – status register, accumulator, program counter, stack pointer, general purpose registers. Processor operation – instruction cycle, instruction fetch, instruction decode, instruction execute.	12
II	8051 Architecture: Block diagram of 8051, Pin configuration, Registers, Internal Memory, Timers, Port Structures, Interrupts, Addressing Modes, Instruction set (brief study of 8051 instruction set).	12
III	Programming and Interfacing of 8051: Simple assembly language programs- addition, subtraction, multiplication, and division. Interfacing of LCD display, Keyboard, Stepper Motor, DAC, and ADC -with 8051 and its programming.	12
IV	Open-Source Embedded Development Boards - Introduction to ATmega 2560 microcontroller - block diagram and pin description, Introduction to Arduino Mega 2560 board, Simple applications- Solar tracker, 4- digit 7 segment LED display, Tilt sensor, Home security alarm system, Digital Thermometer, IoT applications.	12



V	ARM Based System: Introduction - ARM family, ARM 7 register architecture. ARM programmer's model. Introduction to Raspberry pi 4 board, Applications- Portable Bluetooth speaker, remote controlled car, Photo Booth, IoT weather station, Home automation centre, Portal Digital eBook Library.	12
	Total hours	60

vi) ASSESSMENT PATTERN**Mark distribution**

Total Marks	Continuous Internal Evaluation Marks	End Semester Evaluation Marks	End Semester Examination Duration
150	50	100	3 Hours

Continuous Internal Evaluation Pattern:

Attendance	10 Marks
Continuous Assessment Tests (2 numbers)	25 Marks
Assignment/Quiz/Course project	15 Marks

End Semester Examination Pattern:

There will be two parts; Part A and Part B. Part A contain 10 questions with 2 questions from each module, having 3 marks for each question. Students should answer all questions. Part B contains 2 questions from each module of which student should answer any one. Each question can have maximum 2 sub-divisions and carry 14 marks.



Course Code	Course Name	Category	L	T	P	Credit	Year of Introduction
ECTM 204	DIGITAL COMMUNICATION	MINOR (Basket-2)	3	1	0	4	2020

i) **PREREQUISITE:** NIL

ii) **COURSE OVERVIEW**

The goal of this course is to expose the students to various sources coding schemes and signalling codes in telephony. It also gives an idea on various modulation and channel coding schemes in a digital transmission system.

iii) **COURSE OUTCOMES**

After the completion of the course, the student will be able to:

Course Outcomes	Description	Level
CO 1	Explain various source coding schemes.	Understand
CO 2	Describe various signalling codes in telephony.	Understand
CO 3	Apply the knowledge of digital modulation schemes in a digital transmission system.	Apply
CO 4	Explain various channel coding techniques and receivers in a digital transmission system.	Understand

iv) **SYLLABUS**

Linear Source Coding

Elements of digital communication system. Sources, channels and receivers. Classification of communication channels. Discrete sources. Source coding techniques. Waveform coding methods. Sampling theorem. Sampling and reconstruction. Pulse code modulation. Sampling, quantization and encoding. Different quantizers. A-law and mu-law quantization. Practical 15 level mu and A law encoding.

Nonlinear Source Coding

Differential PCM, adaptive PCM, Delta modulator and adaptive delta modulator. Issues in delta modulation. Slope overload.

Signaling Codes in Telephony

Signalling codes in digital telephony. T1 signalling system. AMI and Manchester codes. Binary N-zero substitution, B3ZS code, B6ZS code.

Digital Modulation Schemes

Digital modulation schemes. Baseband BPSK system and the signal constellation. BPSK transmitter and receiver. Baseband QPSK system and Signal constellations. Plots of BER Vs SNR (Analysis not required). QPSK transmitter and receiver. Quadrature amplitude modulation.

**Channel Coding and Receivers**

Transmission through AWGN Channel. Capacity of an AWGN channel. Receivers. Correlation and matched filter receiver. Channel coding schemes. Repetition code. Block codes Cyclic codes.

v) (a) TEXT BOOKS

- 1) Simon Haykin, *Communication Systems*, 4/e ,Wiley India, 2012
- 2) John G. Proakis, Masoud Salehi, *Digital Communication*, 5/e McGraw Hill Education Edition, 2014

(b) OTHER REFERENCES

- 1) John C. Bellamy, *Digital Telephony*, 3/e,Wiley,2000.
- 2) H.Taub and Schilling, *Principles of Communication Systems*, TMH, 2007.
- 3) Couch, *Digital and Analog Communication Systems*, 8/e, Pearson Education India, 2013.
- 4) Ramakrishna Rao, *Digital communication*, Tata McGraw Hill Education Pvt. Limited, 2017.

vi) COURSE PLAN

Module	Contents	No. of hours
I	Linear Source Coding: Elements of digital communication system. Sources, channels and receivers. Classification of communication channels. Discrete sources. Source coding techniques. Waveform coding methods. Sampling theorem. Sampling and reconstruction. Pulse code modulation. Sampling, quantization and encoding. Different quantizers. A-law and mu-law quantization. Practical 15 level mu and A law encoding.	12
II	Nonlinear Source Coding: Differential PCM, adaptive PCM, Delta modulator and adaptive delta modulator. Issues in delta modulation. Slope overload.	12
III	Signaling Codes in Telephony : Signaling codes in digital telephony. T1 signalling system. AMI and Manchester codes. Binary N-zero substitution, B3ZS code, B6ZS code.	12
IV	Digital Modulation: Digital modulation schemes. Baseband BPSK system and the signal constellation. BPSK transmitter and receiver. Base band QPSK system and Signal constellations. Plots of BER Vs SNR(Analysis not required). QPSK transmitter and receiver. Quadrature amplitude modulation.	12
V	Channel Coding and Receivers: Transmission through AWGN Channel. Capacity of an AWGN channel. Receivers. Correlation and matched filter receiver. Channel coding schemes. Repetition code. Block codes Cyclic codes.	12
	Total hours	60

**vii) ASSESSMENT PATTERN****Mark distribution**

Total Marks	Continuous Internal Evaluation Marks	End Semester Evaluation Marks	End Semester Examination Duration
150	50	100	3 Hours

Continuous Internal Evaluation Pattern:

Attendance	10 Marks
Continuous Assessment Tests (2 numbers)	25 Marks
Assignment/Quiz/Course project	15 Marks

End Semester Examination Pattern:

There will be two parts; Part A and Part B. Part A contain 10 questions with 2 questions from each module, having 3 marks for each question. Students should answer all questions. Part B contains 2 questions from each module of which student should answer any one. Each question can have maximum 2 sub-divisions and carry 14 marks.



Course Code	Course Name	Category	L	T	P	Credit	Year of Introduction
EC0M20F	INTRODUCTION TO DIGITAL SIGNAL PROCESSING	MINOR (Basket-3)	3	1	0	4	2020

- i) **PREREQUISITE:** EC0M20C – Introduction to Signals and Systems
- ii) **COURSE OVERVIEW:** The course aims to introduce the concept of converting a continuous time signal to its digital versions and its analysis using Fourier transform. It also deals with the design and realization of FIR and IIR filters and practical limitations of their implementation. It gives an introduction about the structure of a DSP processor.

iii) **COURSE OUTCOMES**

After the completion of the course, the student will be able to:

Course Outcomes	Description	Level
CO 1	Explain how digital signals are obtained from continuous time signals	Understand
CO 2	Apply the concepts to analyse digital signals using Fourier transform	Apply
CO 3	Apply the concepts to design analog and digital filters	Apply
CO 4	Apply the concepts to analyse the practical limitations in DSP implementation	Apply
CO 5	Explain the structure of a DSP architecture	Understand

iv) **SYLLABUS**

Signal Processing Fundamentals: Discrete-time and digital signals. Basic elements of digital processing system- ADC, DAC and Nyquist rate. Frequency aliasing due to sampling. Need for anti-aliasing filters. Discrete Time Fourier Transforms – Properties. Computation of spectrum

Discrete Fourier Transform – Properties and Application: Discrete Fourier transform - DFT as a linear transformation, Properties - circular convolution. Filtering of long data Sequences - FFT-Radix-2 DIT and DIF algorithms. Computational complexity of DFT and FFT –application

Digital Filters: Digital FIR Filter: Transfer function - Difference equation, Linear phase FIR filter, Concept of windowing, Direct form and cascade realization of FIR and IIR filters. Digital IIR Filters - Transfer function, Difference equation. Direct and parallel Structures. Design of analogue Butterworth filters, Analog frequency transformations, Impulse invariance method. Bilinear transformation, Analog prototype to digital transformations.



Finite word length effects in digital filters and DSP Hardware: Fixed point arithmetic, Floating point arithmetic, Truncation and Rounding, Quantization error in ADC, Overflow error, Product round off error, Scaling, Limit cycle oscillation.

General and special purpose hardware for DSP: Computer architectures for DSP – Harvard, pipelining, MAC, special instruction, replication, on chip cache. General purpose digital signal processors (TMS 320 family) - Implementation of digital filtering on DSP processor. Special purpose DSP hardware.

v) (a) TEXT BOOKS

- 1) John G Proakis, G. Manolakis, “*Digital Signal Processing : Principles , Algorithms, and Applications*”, Pearson Education, New Delhi, 4/e, 2007.
- 2) Alan V. Oppenheim, Ronald W. Schaffer, “*Discrete time signal processing*”, Prentice Hall, 3/e, 2009.
- 3) Rulph chassing, “*Digital Signal Processing and applications with C6713 and C6416 DSK*”, Wiley, Kindle edition, 2005.

(b) REFERENCES

- 1) Sanjit K Mitra, “*Digital Signal Processing, A Computer based Approach*”, Tata McGraw-Hill, New Delhi, 4/e, 2011.
- 2) Emmanuel I. feacher, and Barrie W. Jervis, “*Digital Signal Processing-A Practical Approach*”, Pearson Education, 2/e, 2011
- 3) Ramesh Babu, “*Digital Signal Processing*”, Scitech Publications, 7/e, 2017

vi) COURSE PLAN

Module	Contents	No. of hours
I	Signal Processing Fundamentals: Discrete-time and digital signals. Basic elements of digital processing system- ADC, DAC and Nyquist rate. Frequency aliasing due to sampling. Need for anti-aliasing filters. Discrete Time Fourier Transforms – Properties. Computation of spectrum	12
II	Discrete Fourier Transform – Properties and Application Discrete Fourier transform - DFT as a linear transformation, Properties - circular convolution. Filtering of long data sequences - FFT-Radix-2 DIT and DIF algorithms. Computational complexity of DFT and FFT – application	14
III	Digital Filters Digital FIR Filter: Transfer function - Difference equation, Linear phase FIR filter, Concept of windowing, Direct form and cascade realization of FIR and IIR filters. Digital IIR Filters - Transfer function, Difference equation. Direct and parallel Structures. Design of analogue Butterworth filters, Analog frequency transformations, Impulse invariance method. Bilinear transformation, Analog prototype to digital transformations	14



IV	Finite word length effects in digital filters and DSP Hardware Fixed point arithmetic, Floating point arithmetic, Truncation and Rounding, Quantization error in ADC, Overflow error, Product round off error, Scaling, Limit cycle oscillation.	10
V	General and special purpose hardware for DSP: Computer architectures for DSP – Harvard, pipelining, MAC, special instruction, replication, on chip cache. General purpose digital signal processors (TMS 320 family) - Implementation of digital filtering on DSP processor. Special purpose DSP hardware	10
	Total hours	60

vii) ASSESSMENT PATTERN**Mark distribution**

Total Marks	Continuous Internal Evaluation Marks	End Semester Evaluation Marks	End Semester Examination Duration
150	50	100	3 Hours

Continuous Internal Evaluation Pattern:

Attendance	10 Marks
Continuous Assessment Tests (2 numbers)	25 Marks
Assignment/Quiz/Course project	15 Marks

End Semester Examination Pattern:

There will be two parts; Part A and Part B. Part A contain 10 questions with 2 questions from each module, having 3 marks for each question. Students should answer all questions. Part B contains 2 questions from each module of which student should answer any one. Each question can have maximum 2 sub-divisions and carry 14 marks.



HONOURS



Course Code	Course Name	Category	L	T	P	Credit	Year of Introduction
EC1H20A	NANOELECTRONICS	Honours (Basket-1)	4	0	0	4	2020

i) **PREREQUISITE:** PH0U10A Engineering Physics A, EC1U20A Solid State Devices

ii) **COURSE OVERVIEW:**

The goal of this course is to introduce the students to the fundamental concepts of nanoelectronics and nanoelectronic devices.

iii) **COURSE OUTCOMES**

After the completion of the course, the student will be able to:

Course Outcomes	Description	Level
CO 1	Explain the fundamental concepts associated with low dimensional semiconductors.	Understand
CO 2	Explain the methods of fabrication of nanoparticles and nanolayers.	Understand
CO 3	Describe the various characterization tools for nanomaterials.	Understand
CO 4	Describe the carrier transport mechanisms in different nano devices.	Understand
CO 5	Discuss the structure and operation of various nanoscale devices.	Understand

iv) **SYLLABUS**

Introduction to nanotechnology- characteristic lengths in mesoscopic systems , Quantum mechanical coherence- Low dimensional structures, Quantum wells, wires and dots, Density of states of 1D and 2D nanostructures-Square, parabolic and triangular quantum wells – basic properties.

Introduction to methods of fabrication of nanolayers- physical vapour deposition –evaporation and sputtering, chemical vapour deposition, Molecular Beam Epitaxy, Ion Implantation, Formation of Silicon Dioxide. Fabrication of nanoparticles- grinding with iron balls, laser ablation, reduction methods, sol gel, self-assembly, precipitation of quantum dots.

Introduction to characterization of nanostructures: Principle of operation of Scanning, Tunnelling Microscope, Atomic Force Microscope, Scanning Electron microscope – Specimen interactions, Transmission Electron Microscope, X-Ray diffraction analysis.

Quantum wells, modulation doped quantum wells, multiple quantum wells, Concept of super lattices, Kronig - Penney model of super lattice. Transport of charge in Nanostructures-Electron scattering mechanisms, Hot electrons, Resonant tunnelling transport, Coulomb blockade, Effect of magnetic field on a crystal. Aharonov-Bohm effect, the Shubnikov-de Hass effect.



Nanoelectronic devices - MODFET, Single electron Transistor, CNT transistors, Properties of graphene, Resonant tunnel effect – RTD, RTT, Hot electron transistors, Quantum well laser, quantum dot LED, quantum dot laser.

v) (a) TEXT BOOKS

- 1) J.M. Martinez-Duart, R.J. Martin Palma, F. Agulle Rueda, Nanotechnology for Microelectronics and optoelectronics, Elsevier, 2006.
- 2) W.R. Fahrner, Nanotechnology and Nanoelectronics, Springer, 2005
- 3) Chattopadhyay, Banerjee, Introduction to Nanoscience & Technology, PHI, 2012.

(b) REFERENCES

- 1) George W. Hanson, Fundamentals of Nanoelectronics, Pearson Education, 2009.
- 2) Murty, Shankar, Text book of Nanoscience and Nanotechnology, Universities Press, 2012.
- 3) Supriyo Dutta, Quantum Transport- Atom to transistor, Cambridge, 2013.

vi) COURSE PLAN

Module	Contents	No. of hours
I	Introduction to nanotechnology, Limitations of conventional microelectronics, characteristic lengths in mesoscopic systems, Quantum mechanical coherence. Low dimensional structures - Quantum wells, wires and dots, Density of states of 1D and 2D nanostructures. Basic properties of square quantum wells of finite depth, parabolic and triangular quantum wells	13
II	Introduction to methods of fabrication of nano-layers: physical vapour deposition- evaporation & Sputtering, Chemical vapour deposition, Molecular Beam Epitaxy, Ion Implantation, Formation of Silicon Dioxide- dry and wet oxidation methods. Fabrication of nanoparticles- grinding with iron balls, laser ablation, reduction methods, sol gel, self assembly, precipitation of quantum dots.	12
III	Introduction to characterization of nanostructures: Principle of operation of Scanning Tunnelling, Microscope, Atomic Force Microscope, Scanning Electron microscope - specimen interaction, X- Ray Diffraction analysis	11
IV	Quantum wells, multiple quantum wells, Modulation doped quantum wells, concept of super lattices Kronig - Penney model of super lattice. Transport of charge in Nanostructures - Electron scattering mechanisms, Hot electrons, Resonant tunnelling transport, Coulomb blockade, Effect of magnetic field on a crystal. Aharonov-Bohm effect, the Shubnikov-de Hass effect.	13



V	Nanoelectronic devices - MODFETS, Single Electron Transistor, CNT transistors – Properties of graphene Resonant tunnel effect, RTD, RTT, Hot electron transistors Quantum well laser, quantum dot LED, quantum dot laser	11
	Total hours	

vii) ASSESSMENT PATTERN

viii) Mark distribution

Total Marks	Continuous Internal Evaluation Marks	End Semester Evaluation Marks	End Semester Examination Duration
150	50	100	3 Hours

Continuous Internal Evaluation Pattern:

Attendance	10 Marks
Continuous Assessment Tests (2 numbers)	25 Marks
Assignment/Quiz/Course project	15 Marks

End Semester Examination Pattern:

There will be two parts; Part A and Part B. Part A contain 10 questions with 2 questions from each module, having 3 marks for each question. Students should answer all questions. Part B contains 2 questions from each module of which student should answer any one. Each question can have maximum 2 sub-divisions and carry 14 marks.



Course Code	Course Name	Category	L	T	P	Credit	Year of Introduction
EC1H20B	STOCHASTIC PROCESSES FOR COMMUNICATION	Honours (Basket-2)	4	0	0	4	2020

i) COURSE OVERVIEW:

This course aims to apply the concepts of probability and random processes in communication systems.

ii) COURSE OUTCOMES

After the completion of the course, the student will be able to:

Course Outcomes	Description	Level
CO 1	Apply the concepts of probability, random variables and stochastic processes	Apply
CO 2	Apply the concepts in probability to statistically characterize communication channels	Apply
CO 3	Apply the concepts of probability to find information and entropy	Apply
CO 4	Explain source coding and channel coding theorem.	Understand
CO 5	Explain stochastic processes in data transmission	Understand

iii) SYLLABUS**Review of Probability and Random Variables-**

Review of probability- Relative frequency and Axiomatic definitions of probability, Significance of axiomatic definition; Bayes theorem and conditional probability, Independence.

Discrete random variables- The cumulative distribution and density functions for discrete random variables; Joint distribution and conditional distribution;

Statistical averages-Mean, Variance and standard deviation, Gaussian density function, Pdf of envelop of two Gaussian variables – Rayleigh Pdf.

Review of Random Processes –

Stochastic Processes- Stationarity and ergodicity; WSS and SSS processes; Gaussian Random process, Mean and autocorrelation and power spectral density functions; Weiner Kinchine theorem, Bandwidth of a random process, PSD of a Pulse Amplitude Modulated wave. White noise, Filtering of discrete WSS process by LTI systems; Noise-equivalent bandwidth, Signal to Noise Ratio, Matched Filter, Band-limited and narrowband random process; Sum of random variables, Markov Inequality, Chebyshev Inequality, Convergence, The central limit theorem (statement only). Gaussianity of thermal noise.

Entropy and Information-

Basics of discrete communication system, Sources, channels and receivers; Discrete memoryless sources; Entropy; Source coding theorem (statement only); Mutual Information; Discrete memoryless channels; Matrix of channel transmission probabilities; Noiseless and noisy channels,



binary symmetry channels; Channel coding theorem (statement only) Channel capacity for BSC (derivation required), Differential entropy, Channel capacity of AWGN channel (statement only).

Markov Process and Queuing Theory-

Markov process- Definition and model, Markov chain- Transition probability matrix, State diagram and characteristics of a Markov chain; Chapman Kolmogorov equation; Poisson process.

Queues in Communication Networks-

Overview of queuing theory. M/M/1, M/M/∞, Application to packet transmission in a slotted ALOHA computer communication network.

iv) a) TEXT BOOKS

- 1) Papaulis and Unnikrishna Pillai, Probability, Random Variables and Stochastic Processes, 4/e, MH, 2002.
- 2) Hsu, Analog and Digital Communication Systems, Schaum Outline Series, 3/e, 2017, MGH.

b) REFERENCES

- 1) John G Proakis ,Masoud Salehi, Digital Communications, 5/e, MGH, 2018.
- 2) Miller and Childers, Probability and Random Processes, 2/e, Academic Press, 2012.
- 3) Bertsekas and Gallager, Data Networks, 2/e, PHI,2015.

v) COURSE PLAN

Module	Contents	No. of hours
I	Review of probability- Relative frequency and Axiomatic definitions of probability, Significance of axiomatic definition. Bayes theorem and conditional probability. Independence. Discrete random variables. The cumulative distribution and density functions for discrete random variables. Joint distribution and conditional distribution. Statistical averages. Mean, Variance and standard deviation, Gaussian density function, Pdf of envelop of two gaussian variables – Rayleigh Pdf.	12
II	Stochastic Processes- Stationarity and ergodicity. WSS and SSS processes. Gaussian Random process, Mean and autocorrelation and power spectral density functions. Weiner Kinchine theorem, Bandwidth of a random process, PSD of a Pulse Amplitude Modulated wave. White noise, Filtering of discrete WSS process by LTI systems. Noise equivalent bandwidth, Signal to Noise Ratio, Matched Filter, Band-limited and narrowband random process. Sum of random variables, Markov Inequality, Chebyshev Inequality, Convergence, The central limit theorem (statement only). Gaussianity of thermal noise.	12



III	Basics of discrete communication system, Sources, channels and receivers. Discrete memoryless sources. Entropy. Source coding theorem (statement only). Mutual Information. Discrete memoryless channels. Matrix of channel transmission probabilities. Noiseless and noisy channels, binary symmetry channels. Channel coding theorem (statement only) Channel capacity for BSC (derivation required), Differential entropy, Channel capacity of AWGN channel (statement only).	12
IV	Markov process. Definition and model. Markov chain. Transition probability matrix. State diagram and characteristics of a Markov chain. Chapman Kolmogorov equation. Poisson process	12
V	Overview of queuing theory. M/M/1, M/M/ ∞ systems Application to packet transmission in a slotted ALOHA computer communication network.	12
	Total hours	60

vi) ASSESSMENT PATTERN**Mark distribution**

Total Marks	Continuous Internal Evaluation Marks	End Semester Evaluation Marks	End Semester Examination Duration
150	50	100	3 Hours

Continuous Internal Evaluation Pattern:

Attendance	10 Marks
Continuous Assessment Tests (2 numbers)	25 Marks
Assignment/Quiz/Course project	15 Marks

End Semester Examination Pattern:

There will be two parts; Part A and Part B. Part A contain 10 questions with 2 questions from each module, having 3 marks for each question. Students should answer all questions. Part B contains 2 questions from each module of which student should answer any one. Each question can have maximum 2 sub-divisions and carry 14 marks.



Course Code	Course Name	Category	L	T	P	Credit	Year of Introduction
EC1H20C	STOCHASTIC SIGNAL PROCESSING	Honours (Basket-3)	3	1	0	4	2020

i) COURSE OVERVIEW

The course aims to introduce the stochastic systems and their interactions with LTI systems.

ii) COURSE OUTCOMES

After the completion of the course, the student will be able to:

Course Outcomes	Description	Level
CO 1	Explain the concepts of probability, random variables and stochastic processes	Understand
CO 2	Apply the concepts in probability to statistically analysing the signals	Apply
CO 3	Apply the properties of WSS for finding the LTI system response	Apply
CO 4	Apply the concepts to model discrete systems using various methods	Apply
CO 5	Explain the concepts to estimate the spectra of signals using various methods	Understand

iii) SYLLABUS

Review of Probability and Random Variables: Review of probability. Relative frequency and Axiomatic definitions of probability, Significance of axiomatic definition. Bayes theorem and conditional probability. Independence. Discrete random variables. The cumulative distribution and density functions for random variables. Joint distribution and conditional distribution. Statistical averages. Mean, Variance and standard deviation, Functions of random variables. Multivariate Gaussian density function.

Review of Random Processes: Stochastic Processes. Stationarity and ergodicity. WSS and SSS processes. Discrete Gaussian, Rayleigh and Rician processes. Sums of random variables, Convergence, Markov and Chebyshev inequality, The central limit theorem (statement only).

The Autocorrelation Matrix and its Significance: Statistical averages of discrete stationary stochastic processes. Mean and autocorrelation and power spectral density functions. Weiner Kinchine theorem, Filtering of discrete WSS process by LTI systems. The autocorrelation matrix and the significance of its eigen vectors. Whitening. Properties of autocorrelation matrix, its inversion and Levinson-Durbin Recursion. Wiener-Hopf equation. Brownian motion, its mathematical model and its autocorrelation and power spectral density

Signal Modeling - Deterministic and Stochastic: The least square method of signal modeling. The Pade approximation. Prony's method. Stochastic models, AR, MA and ARMA models.

Spectrum Estimation: Periodogram method of spectrum estimation. Parametric methods AR, MA and ARMA methods

**iv)(a) TEXT BOOKS**

- 1) Monson Hayes, “*Statistical Digital Signal Processing and Modelling*”, John Wiley and Sons, 4/e, 2002.
- 2) A. Papaulis and Unnikrishna Pillai, “*Probability, Random Variables and Stochastic Processes*”, McGraw Hill, 4/e, 2017

(b) OTHER REFERENCES

- 1) V. Sundarapandian, “*Probability, Statistics and Queueing theory*”, PHI Learning, 2009
- 2) Hossein Pishro-Nik, “*Introduction to Probability, Statistics and Random Processes*”, <https://www.probabilitycourse.com>, Kappa Research LLC, 2014.
- 3) Oliver C Ibe, “*Fundamentals of Applied Probability and Random Processes*”, Elsevier, 2/e, 2014.
- 4) T Veerarajan “*Probability Statistics and Random Process*”, McGraw Hill, 3/e, 2008.

v) COURSE PLAN

Module	Contents	No. of hours
I	Review of probability and random variables: Review of probability. Relative frequency and Axiomatic definitions of probability, Significance of axiomatic definition. Bayes theorem and conditional probability. Independence. Discrete random variables. The cumulative distribution and density functions for random variables. Joint distribution and conditional distribution. Statistical averages. Mean, Variance and standard deviation, Functions of random variables. Multivariate Gaussian density function	14
II	Review of probability and random processes: Stochastic Processes. Stationarity and ergodicity. WSS and SSS processes. Discrete Gaussian, Rayleigh and Rician processes. Sums of random variables, Convergence, Markov and Chebyshev inequality, The central limit theorem (statement only)	13
III	Autocorrelation matrix and its significance: Statistical averages of discrete stationary stochastic processes. Mean and autocorrelation and power spectral density functions. Weiner Kinchine theorem, Filtering of discrete WSS process by LTI systems. The autocorrelation matrix and the significance of its eigen vectors. Whitening. Properties of autocorrelation matrix, its inversion and Levinson-Durbin Recursion. Wiener-Hopf equation. Brownian motion, its mathematical model and its autocorrelation and power spectral density	13
IV	Signal Modelling - Deterministic and Stochastic: The least square method of signal modeling. The Pade approximation. Prony's method. Stochastic models, AR, MA and ARMA models	10



V	Spectrum estimation: Periodogram method of spectrum estimation. Parametric methods AR, MA and ARMA methods.	10
	Total hours	60

vi) ASSESSMENT PATTERN**Mark distribution**

Total Marks	Continuous Internal Evaluation Marks	End Semester Evaluation Marks	End Semester Examination Duration
150	50	100	3 Hours

Continuous Internal Evaluation Pattern:

Attendance	10 Marks
Continuous Assessment Tests (2 numbers)	25 Marks
Assignment/Quiz/Course project	15 Marks

End Semester Examination Pattern:

There will be two parts; Part A and Part B. Part A contain 10 questions with 2 questions from each module, having 3 marks for each question. Students should answer all questions. Part B contains 2 questions from each module of which student should answer any one. Each question can have maximum 2 sub-divisions and carry 14 marks.



SEMESTER V



Course Code	Course Name	Category	L	T	P	Credit	Year of Introduction
EC1U30A	LINEAR INTEGRATED CIRCUITS	PCC	3	1	0	4	2020

i) **PREREQUISITE:**EC1U20D - Analog Circuits

ii) **COURSE OVERVIEW**

Goal of this course is to develop the skill to design circuits using operational amplifiers and other linear ICs for various applications.

iii) **COURSE OUTCOMES**

After the completion of the course, the student will be able to

Course Outcomes	Description	Level
CO 1	Explain the Op Amp fundamentals and differential amplifier configurations	Understand
CO 2	Design operational amplifier circuits for various applications	Apply
CO 3	Design Oscillators and active filters using op amps	Apply
CO 4	Explain the working and applications of timer, VCO and PLL ICs	Understand
CO 5	Describe the working of Voltage regulator IC's and Data converters	Understand

iv) **SYLLABUS**

Operational amplifiers (Op Amps): The 741 Op Amp, Block diagram, Ideal op-amp parameters, typical parameter values for 741, Equivalent circuit, Open loop configurations

Differential Amplifiers: Differential amplifier, DC and AC Analysis, CMRR, input and output resistance, Voltage gain. Constant current bias, constant current source.

Op-amp with negative feedback: General concept of Voltage Series, current series and current shunt negative feedback, Op Amp circuits with voltage series and voltage shunt feedback, Virtual ground Concept.

Op-amp applications: Summer, Voltage Follower-loading effects, Integrator, Differentiator, Precision rectifiers, Comparators, Schmitt Triggers, Log and antilog amplifiers.

Op-amp Oscillators and Multivibrators: Phase Shift and Wien-bridge Oscillators, Triangular and Sawtooth waveform generators, Astable and monostable multivibrators.

Active filters: Comparison with passive filters, First and second order low pass, High pass, Band pass and band reject active filters, state variable filters.

Timer and VCO: Timer IC 555- Functional diagram, Astable and monostable operations. Voltage Controlled Oscillator and applications, Phase Locked Loop – PLL IC 565, Applications of PLL.

Voltage Regulators: Fixed and Adjustable voltage regulators, IC 723, Current boosting, Current limiting, Short circuit and Fold-back protection.

Data Converters: Digital to Analog converters, Specifications, Weighted resistor type and R-2R Ladder type.

Analog to Digital Converters: Specifications, Flash type and Successive approximation type.

**v) a) TEXT BOOKS**

- 1) Roy D. C. and S. B. Jain, *Linear Integrated Circuits*, 5/e, New Age International, 2018

b) REFERENCES

- 2) DFranco S., *Design with Operational Amplifiers and Analog Integrated Circuits*, 4/e, Tata McGraw Hill, 2016
- 3) Gayakwad R. A., *Op-Amps and Linear Integrated Circuits*, 4/e, Prentice Hall, 2010
- 4) Salivahanan S. and V. S. K. Bhaaskaran, *Linear Integrated Circuits*, 3/e, Tata McGrawHill, 2018
- 5) Botkar K. R., *Integrated Circuits*, 10/e, Khanna Publishers, 2010
- 6) C.G. Clayton, *Operational Amplifiers*, Butterworth & Company Publ. Ltd. Elsevier, 1971
- 7) David A. Bell, *Operational Amplifiers & Linear ICs*, 3/e, Oxford University Press, 2011
- 8) R.F. Coughlin & Fredrick Driscoll, *Operational Amplifiers & Linear Integrated Circuits*, 6/e, PHI, 2001
- 9) Sedra A. S. and K. C. Smith, *Microelectronic Circuits*, 7/e, Oxford University Press, 2017

vi) COURSE PLAN

Module	Contents	No. of hours
I	<p>Operational amplifiers (Op Amps): The 741 Op Amp, Block diagram, Ideal op-amp parameters, typical parameter values for 741, Equivalent circuit, Open loop configurations, Voltage transfer curve, Frequency response curve.</p> <p>Differential Amplifiers: Differential amplifier configurations using BJT, DC Analysis- transfer characteristics; AC analysis- differential and common mode gains, CMRR, input and output resistance, Voltage gain. Constant current bias, constant current source; Concept of current mirror-the two-transistor current mirror, Wilson and Widlar current mirrors.</p>	12
II	<p>Op-amp with negative feedback: General concept of Voltage Series, Voltage Shunt, current series and current shunt negative feedback, Op Amp circuits with voltage series and voltage shunt feedback, Virtual ground Concept; analysis of practical inverting and non-inverting amplifiers for closed loop gain, Input Resistance and Output Resistance.</p> <p>Op-amp applications: Summer, Voltage Follower-loading effects, Differential and Instrumentation Amplifiers, Voltage to current and Current to voltage converters, Integrator, Differentiator, Precision rectifiers, Comparators, Schmitt Triggers, Log and antilog amplifiers.</p>	12
III	<p>Op-amp Oscillators and Multivibrators: Phase Shift and Wien-bridge Oscillators, Triangular and Sawtooth waveform generators, Astable and monostablemultivibrators.</p> <p>Active filters: Comparison with passive filters, First and second order low pass, High pass, Band pass and band reject active filters, state</p>	12



	variable filters.	
IV	Timer and VCO: Timer IC 555- Functional diagram, Astable and monostable operations. Basic concepts of Voltage Controlled Oscillator and application of VCO IC LM566, Phase Locked Loop – Operation, Closed loop analysis, Lock and capture range, Basic building blocks, PLL IC 565, Applications of PLL.	12
V	Voltage Regulators: Fixed and Adjustable voltage regulators, IC 723 – Low voltage and high voltage configurations, Current boosting, Current limiting, Short circuit and Fold-back protection. Data Converters: Digital to Analog converters, Specifications, Weighted resistor type and R-2R Ladder type. Analog to Digital Converters: Specifications, Flash type and Successive approximation type.	12
	Total hours	60

vii) ASSESSMENT PATTERN

Mark distribution

Total Marks	Continuous Internal Evaluation Marks	End Semester Evaluation Marks	End Semester Examination Duration
150	50	100	3 Hours

Continuous Internal Evaluation Pattern:

Attendance	10 Marks
Continuous Assessment Tests (2 numbers)	25 Marks
Assignment/Quiz/Course project	15 Marks

It is mandatory that a *course project* shall be undertaken by a student for this subject. The course project must be performed as a software simulation of a typical op-amp based application circuit. Instead of two assignments, two evaluations will be performed on the course project along with continuous assessment tests, each carrying 5 marks. Upon successful completion of the project, a brief report must be submitted by the student which will be evaluated for 5 marks.

End Semester Examination:

There will be two parts; Part A and Part B. Part A contain 10 questions with 2 questions from each module, having 3 marks for each question. Students should answer all questions. Part B contains 2 questions from each module of which student should answer any one. Each question can have maximum 2 sub-divisions and carry 14 marks.



Course Code	Course Name	Category	L	T	P	Credit	Year of Introduction
EC1U30B	DIGITAL SIGNAL PROCESSING	PCC	3	1	0	4	2020

i) **PREREQUISITE:** EC1U20E - Signals and systems

ii) **COURSE OVERVIEW**

This course aims to provide an understanding of the principles, algorithms and applications of DSP.

iii) **COURSE OUTCOMES**

After the completion of the course, the student will be able to

Course Outcomes	Description	Level
CO 1	Analyze discrete time signals and systems in time and frequency domains.	Apply
CO 2	Design digital FIR filters for specific applications using various techniques.	Apply
CO 3	Design analog and digital IIR filters for specific applications using various techniques.	Apply
CO 4	Design digital filter structures using different realization techniques.	Apply
CO 5	Explain the basic design aspects of DSP systems using TMS320C6713 processor.	Understand
CO 6	Analyze multirate digital signal processing systems.	Apply

iv) **SYLLABUS**

Discrete Fourier Transform and its Properties, Linear Filtering methods based on the DFT, Frequency analysis of signals using the DFT, Computation of DFT, FFT Algorithms, IDFT computation using Radix-2 FFT Algorithms, Efficient computation of DFT of two real sequences and a 2N-Point real sequence, Design of FIR Filters, Design of linear phase FIR Filters using window methods and frequency sampling method, Design of IIR Digital Filters From Analog Filters, IIR Filter Design, Frequency Transformations, FIR Filter Structures, IIR Filter Structures, Introduction to TMS320C67xx digital signal processor, Multi-rate Digital Signal Processing, Finite word length effects in DSP systems, IIR digital filters, FFT algorithms.

v) a) **TEXT BOOKS**

- 1) Proakis J. G. and Manolakis D. G., *Digital Signal Processing, 4/e*, Pearson Education, 2007
- 2) Alan V Oppenheim, Ronald W. Schaffer, *Discrete-Time Signal Processing*, 3rd Edition, Pearson, 2010



3) Mitra S. K., *Digital Signal Processing: A Computer Based Approach, 4/e*, McGraw Hill (India), 2014

b) REFERENCES

- 1) Ifeachor E.C. and Jervis B. W., *Digital Signal Processing: A Practical Approach, 2/e* Pearson Education, 2009
- 2) Lyons, Richard G., *Understanding Digital Signal Processing, 3/e*. Pearson Education India, 2004
- 3) Salivahanan S, *Digital Signal Processing, 4e*, McGraw Hill Education New Delhi, 2019
- 4) Chassaing, Rulph., *DSP applications using C and the TMS320C6x DSK*. Vol. 13. John Wiley & Sons, 2003
- 5) Vinay.K.Ingle, John.G.Proakis, *Digital Signal Processing: Bookware Companion Series*, Thomson, 2004
- 6) Chen, C.T., *“Digital Signal Processing: Spectral Computation & Filter Design*, Oxford Univ. Press, 2001
- 7) Monson H Hayes, *“Schaums outline: Digital Signal Processing”*, McGraw Hill Professional, 1999

vi) COURSE PLAN

Module	Contents	No. of hours
I	Basic Elements of a DSP system, Typical DSP applications, Finite-length discrete transforms, Orthogonal transforms – The Discrete Fourier Transform: DFT as a linear transformation (Matrix relations), Relationship of the DFT to other transforms, IDFT, Properties of DFT and examples. Circular convolution, Linear Filtering methods based on the DFT, linear convolution using circular convolution, Filtering of long data sequences, overlap save and overlap add methods, Frequency Analysis of Signals using the DFT (concept only required)	13
II	Efficient Computation of DFT: Fast Fourier Transform Algorithms- Radix-2 Decimation in Time and Decimation in Frequency FFT Algorithms, IDFT computation using Radix-2 FFT Algorithms, Application of FFT Algorithms, Efficient computation of DFT of Two Real Sequences and a 2N-Point Real Sequence	13
III	Design of FIR Filters - Symmetric and Anti-symmetric FIR Filters, Design of linear phase FIR filters using Window methods, (rectangular, Hamming and Hanning) and frequency sampling method, Comparison of design methods for Linear Phase FIR Filters. Design of IIR Digital Filters from Analog Filters (Butterworth), IIR Filter Design by Impulse Invariance, and Bilinear Transformation, Frequency Transformations in the Analog and Digital Domain.	13
IV	Structures for the realization of Discrete Time Systems - Block diagram and signal flow graph representations of filters, FIR Filter Structures: Linear structures, Direct Form, Cascade Form, IIR Filter Structures: Direct Form, Transposed Form, Cascade Form and Parallel Form,	11



	Computational Complexity of Digital filter structures. Multi-rate Digital Signal Processing: Decimation and Interpolation (Time domain and Frequency Domain Interpretation), Anti- aliasing and anti-imaging filter	
V	Computer architecture for signal processing: Harvard Architecture, pipelining, MAC, Introduction to TMS320C67xx digital signal processor, Functional Block Diagram. Finite word length effects in DSP systems: Introduction (analysis not required), fixed-point and floating-point DSP arithmetic, ADC quantization noise, Finite word length effects in IIRdigital filters: coefficient quantization errors. Finite word length effects in FFT algorithms: Round off errors	10
	Total hours	60

Simulation Assignments

The following simulations may be done in Scilab/ Matlab/ LabView/GNU Octave:

1. Consider a signal given by $x(n)=[1,1,1,1]$.
 - a. Compute the DTFT of the given sequence and plot its magnitude and phase
 - b. Compute the 4 point DFT of the above signal and plot its magnitude and phase
 - c. Compare the above plots and obtain the relationship?
2. Zero pad the sequence $x(n)$ by 4 and compute the 8 point DFT and find the corresponding magnitude and phase plots. Compare the spectra with that in (b) and comment on it.
3. The first five values of the 8 point DFT of a real valued sequence $x(n)$ are given by $\{0.25, 0.125-j0.3, 0, 0.125-j0.06, 0.5\}$. Determine the DFT of each of the following sequences using properties (others may be included). Hint :IDFT may not be computed.
 - a. $x_1(n)=x((2-n))_8$
 - b. $x_3(n)=x(n)$
4. Develop a function to implement the over-lap add method using circular convolution operation.
5. Simulate rational sampler

**vii) ASSESSMENT PATTERN****Mark distribution**

Total Marks	Continuous Internal Evaluation Marks	End Semester Evaluation Marks	End Semester Examination Duration
150	50	100	3 Hours

Continuous Internal Evaluation Pattern:

Attendance	10 Marks
Continuous Assessment Tests (2 numbers)	25 Marks
Assignment/Quiz/Course project	15 Marks

End Semester Examination Pattern:

There will be two parts; Part A and Part B. Part A contain 10 questions with 2 questions from each module, having 3 marks for each question. Students should answer all questions. Part B contains 2 questions from each module of which student should answer any one. Each question can have maximum 2 sub-divisions and carry 14 marks.



Course Code	Course Name	Category	L	T	P	Credit	Year of Introduction
EC1U30C	ANALOG AND DIGITAL COMMUNICATION	PCC	3	1	0	4	2020

i) **PREREQUISITE:**EC1U20E - Signals and Systems, MA0U20C - Probability, Random Process and Numerical Methods

ii) **COURSE OVERVIEW**

Goal of this course is to provide an insight into the concepts of analog and digital communication system.

iii) **COURSE OUTCOMES**

After the completion of the course, the student will be able to

Course Outcomes	Description	Level
CO 1	Compute various parameters of analog modulation systems.	Apply
CO 2	Apply the concepts of random processes to LTI systems.	Apply
CO 3	Apply waveform coding techniques in digital transmission	Apply
CO 4	Apply the knowledge of GS procedure to develop digital receivers.	Apply
CO 5	Apply signal modelling techniques in the design of digital receivers	Apply
CO 6	Apply digital modulation techniques in signal transmission	Apply

iv) **SYLLABUS**

Block diagram of a communication system. Need for analog modulation. Amplitude modulation. Equation and spectrum of AM signal. DSB-SC and SSB systems. Block diagram of SSB transmitter and receiver. Frequency and phase modulation. Narrow and wide band FM and their spectra. FM transmitter and receiver.

Review of random variables – both discrete and continuous. CDF and PDF, statistical averages. (Only definitions, computations and significance) Entropy, differential entropy. Differential entropy of a Gaussian RV. Conditional entropy, mutual information. Stochastic

processes, Stationarity. Conditions for WSS and SSS. Autocorrelation and power spectral density. LTI systems with WSS as input.

Source coding theorems I and II (Statements only). Waveform coding. Sampling and Quantization. Pulse code modulation, Transmitter and receiver. Companding. Practical 15 level A and mu-law companders. DPCM transmitter and receiver. Design of linear predictor. Wiener-Hopf equation. Delta modulation. Slope overload.

Gram-Schmitt procedure. Signal space. Baseband transmission through AWGN channel. Mathematical model of ISI. Nyquist criterion for zero ISI. Signal modeling for ISI, Raised cosine and Square-root raised cosine spectrum, Partial response signalling and duobinary coding. Equalization. Design of zero forcing equalizer. Vector model of AWGN channel. Matched filter



and correlation receivers. MAP receiver, Maximum likelihood receiver and probability of error. Capacity of an AWGN channel (Expression only) -- significance in the design of communication schemes.

Digital modulation schemes. Baseband BPSK system and the signal constellation. BPSK transmitter and receiver. Base band QPSK system and Signal constellations. Plots of BER Vs SNR with analysis. QPSK transmitter and receiver. Quadrature amplitude modulation and signal constellation.

v) a) TEXT BOOKS

- 1) Simon Haykin, *Digital Communication Systems*, 4th edition, Wiley, 2000.
- 2) DSKlar, *Digital Communications: Fundamentals and Applications*, 3/e, Pearson
- 3) John C. Bellamy, *Digital Telephony*, Wiley
- 4) Kennedy, Davis, *Electronics communication Systems*, 4/e

b) REFERENCES

- 1) R. Gallager, *Principles of Digital Communication*, Oxford University Press
- 2) John G Proakis, *Digital Communication*, 4/e, Wiley

vi) COURSE PLAN

Module	Contents	No. of hours
I	Block diagram of communication system, analog and digital systems, need for modulation. Amplitude modulation, model and spectrum and index of modulation DSB-SC and SSB modulation. SSB transmitter and receiver. Frequency and phase modulation. Model of FM, spectrum of FM signal	11
II	Review of random variables, CDF and PDF, examples Entropy of RV, Differential entropy of Gaussian RV, Expectation, conditional expectation, mutual information Stochastic processes, Stationarity, WSS and SSS. Autocorrelation and power spectral density. Response of LTI systems to WSS	12
III	Source coding theorems PCM, Transmitter and receiver, companding Practical A and mu law companders DPCM, Linear predictor, Wiener Hopf equation Delta modulator	12
IV	G-S procedure ISI, Nyquist criterion, RS and SRC, PR signalling and duobinary coding Equalization, design of zero forcing equalizer Vector model of AWGN channel, Correlation receiver, matched filter MAP receiver, ML receiver, probability of error Channel capacity, capacity of Gaussian channel, Its significance in design of digital communication schemes	16
V	Need of digital modulation in modern communication. Baseband BPSK system and the signal constellation. Baseband QPSK system, signal constellation. Effect of AWGN, probability of error (with derivation). BER-SNR curve, QPSK transmitter and receiver. QAM system	9
Total hours		60



The simulation assignments can be done with Python/MATLAB/ SCILAB/LabVIEW
The following simulations can be done in MATLAB, Python,R or LabVIEW.

1. A-Law and μ -Law Characteristics
2. Practical A-Law compander
3. Practical μ -Law compander
4. BPSK Transmitter and Receiver
5. QPSK Transmitter and Receiver
6. Matched Filter Receiver

vii) ASSESSMENT PATTERN

Mark distribution

Total Marks	Continuous Internal Evaluation Marks	End Semester Evaluation Marks	End Semester Examination Duration
150	50	100	3 Hours

Continuous Internal Evaluation Pattern:

Attendance	10 Marks
Continuous Assessment Tests (2 numbers)	25 Marks
Assignment/Quiz/Course project	15 Marks

End Semester Examination Pattern:

There will be two parts; Part A and Part B. Part A contain 10 questions with 2 questions from each module, having 3 marks for each question. Students should answer all questions. Part B contains 2 questions from each module of which student should answer any one. Each question can have maximum 2 sub-divisions and carry 14 marks.



Course Code	Course Name	Category	L	T	P	Credit	Year of Introduction
EC1U30D	CONTROL SYSTEMS	PCC	3	1	0	4	2020

i) **PREREQUISITE:** EC1U20E - Signals and Systems

ii) **COURSE OVERVIEW**

This course aims to develop the skills for mathematical modelling of various control systems and stability analysis using time domain and frequency domain approaches.

iii) **COURSE OUTCOMES**

After the completion of the course, the student will be able to:

Course Outcomes	Description	Level
CO 1	Analyze electromechanical systems by mathematical modeling and derive their transfer functions.	Analyse
CO 2	Analyze the time and frequency domain responses of any control systems for any standard input	Apply
CO 3	Analyze the stability of a system using various techniques	Apply
CO 4	Design a system using controllers to achieve the desired specifications.	Apply
CO 5	Analyze a system using state space analysis	Apply

iv) **SYLLABUS**

Introduction: Basic Components of a Control System, Open-Loop Control Systems and Closed-Loop Control Systems, Examples of control system, Applications.

Feedback and its effects: Types of Feedback Control Systems, Linear versus Nonlinear Control Systems, Time-Invariant versus Time-Varying Systems.

Mathematical modelling of control systems: Electrical Systems and Mechanical systems.

Transfer Function from Block Diagrams and Signal Flow Graphs: Block diagram representation and reduction methods, Signal flow graph reduction using Mason's gain formula.

Time Domain Analysis of Control Systems: Introduction- Standard Test signals, Time response specifications. Time response of first and second order systems to unit step input and ramp inputs, time domain specifications. Steady state error and static error coefficients.

Frequency domain analysis: Frequency domain specifications, correlation between time and frequency responses.

Stability of linear control systems: Concept of BIBO stability, absolute stability, Routh's Hurwitz Criterion.

Root Locus Techniques: Introduction, properties and its construction, Application to system stability studies. Illustration of the effect of addition of a zero and a pole.

Nyquist stability criterion: Fundamentals and analysis.

Relative stability: Gain Margin and Phase Margin. Stability analysis with Bode plot.

Design of Compensators: Need of compensators, design of lag and lead compensators using Bode plots. Effect of P, PI & PID controllers



State Variable Analysis of Linear Dynamic Systems: State variables, state equations, state variable representation of electrical and mechanical systems. Transfer function from State Variable Representation, Solutions of the state equations, state transition matrix. Concept of Controllability and Observability, Kalman's Test, Gilbert's test.

v) a) **TEXT BOOKS**

- 1) FaridGolnaraghi, Benjamin C. Kuo, *Automatic Control Systems*, 9/e, Wiley India
- 2) I.J. Nagarath, M.Gopal, *Control Systems Engineering*, 5/e, New Age International Pub. Co., 2007
- 3) Ogata K., *Discrete-time Control Systems*, 2/e, Pearson Education

b) **REFERENCES**

- 1) I.J. Nagarath, M.Gopal: Scilab Text Companion for Control Systems Engineering (3rd-Edition) —New Age International Pub. Co., 2007
- 2) Norman S. Nise, *Control System Engineering*, 5/e, Wiley India
- 3) M. Gopal, *Digital Control and State Variable Method*, 4/e, McGraw Hill Education India, 2012
- 4) Ogata K., *Modern Control Engineering*, Prentice Hall of India,4/e, Pearson Education, 2002
- 5) Richard C Dorf and Robert H. Bishop, *Modern Control Systems*, 9/e, Pearson Education, 2001

vi) **COURSE PLAN**

Module	Contents	No. of hours
I	<p>Introduction: Basic Components of a Control System, Open-Loop Control Systems and Closed-Loop Control Systems, Examples of control system, Applications.</p> <p>Feedback and its effects: Types of Feedback Control Systems, Linear versus Nonlinear Control Systems, Time-Invariant versus Time-Varying Systems.</p> <p>Mathematical modelling of control systems: Electrical Systems and Mechanical systems. Force Voltage Analogy</p> <p>Transfer Function from Block Diagrams and Signal Flow Graphs: Block diagram representation and reduction Methods. Signal flow graph reduction usingMason's gain formula.</p>	12
II	<p>Time Domain Analysis of Control Systems: Introduction- Standard Test signals, Time response Specifications. Time response of first and second order systems to unit step input and ramp inputs, time domain specifications. Steady state error and static error coefficients.</p> <p>Frequency domain analysis: Frequency domain specifications, correlation between time and frequency responses.</p>	11



III	Stability of linear control systems: Stability of linear control systems: concept of BIBO stability, absolute stability, Routh's Hurwitz Criterion. Root Locus Techniques Introduction, properties and its construction, Application to system stability studies. Illustration of the effect of addition of a zero and a pole.	10
IV	Nyquist stability criterion:Fundamentals and analysis Relative stability: Gain Margin and Phase Margin. Stability analysis with Bode plot. Design of Compensators: Need of compensators, design of lag and lead compensators using Bode plots. Effect of P, PI & PID controllers.	12
V	State Variable Analysis of Linear Dynamic Systems: State variables, state equations, State variable representation of electrical and mechanical systems. State Variable representation from Transfer Function.Transfer function from State Variable Representation, Solutions of the state equations, state transition matrix, Concept of Controllability and Observability and techniques to test them - Kalman's Test, Gilbert's test.	15
	Total hours	60

Simulation Assignment

The following simulations can be done in Python/ Scilab/ Matlab

1. Plot the pole-zero configuration in s-plane for the given transfer function.
2. Determine the transfer function for given closed loop system in block diagram representation.
3. Plot unit step response of given transfer function and find delay time, rise time, peak time and peak overshoot.
4. Determine the time response of the given system subjected to any arbitrary input.
5. Plot root locus of given transfer function, locate closed loop poles for different values of k.
6. Plot bode plot of given transfer function and determine the relative stability by measuring gain and phase margins.
7. Determine the steady state errors of a given transfer function.
8. Plot Nyquist plot for given transfer function and determine the relative stability.
9. Create the state space model of a linear continuous system.
10. Determine the state space representation of the given transfer function.

vii)

**viii) ASSESSMENT PATTERN****Mark distribution**

Total Marks	Continuous Internal Evaluation Marks	End Semester Evaluation Marks	End Semester Examination Duration
150	50	100	3 Hours

Continuous Internal Evaluation Pattern:

Attendance	10 Marks
Continuous Assessment Tests (2 numbers)	25 Marks
Assignment/Quiz/Course project	15 Marks

End Semester Examination Pattern:

There will be two parts; Part A and Part B. Part A contain 10 questions with 2 questions from each module, having 3 marks for each question. Students should answer all questions. Part B contains 2 questions from each module of which student should answer any one. Each question can have maximum 2 sub-divisions and carry 14 marks.



Course Code	Course Name	Category	L	T	P	Credit	Year of Introduction
HS0U30A	INDUSTRIAL ECONOMICS & FOREIGN TRADE	HSC	3	0	0	3	2020

i) **PRE REQUISITE** :NIL

ii) **COURSE OVERVIEW**:

The course enables students to make better economic decisions in wage employment and entrepreneurship using economic alternatives and investment alternatives.

iii) **COURSE OUTCOMES**

After the completion of the course, the student will be able to:

Course Outcomes	Description	Level
CO 1	Explain the problem of scarcity of resources, consumer behaviour and the equilibrium condition of demand and supply.	Understand
CO 2	Demonstrate the production function and equilibrium condition of a producer	Understand
CO 3	Survey the impact of market competition in the functional requirement of a firm and pricing of goods and services.	Analyse
CO 4	Infer the overall performance of the economy, the regulation of economic fluctuations and its impact on various sections in the society.	Analyse
CO 5	Compare the profitability of projects and economic performance of business with the help of capital budgeting methods.	Evaluate
CO 6	Determine the current impact of global economic policies on the business opportunities of a firm	Analyse

iv) **SYLLABUS**

Scarcity and choice - Basic economic problems- PPC – Firms and its objectives – types of firms – Utility – Law of diminishing marginal utility – Demand and its determinants – law of demand – elasticity of demand – measurement of elasticity and its applications – Supply, law of supply and determinants of supply – Equilibrium – Changes in demand and supply and its effects – Consumer surplus and producer surplus (Concepts) – Taxation and deadweight loss.

Production function – law of variable proportion – economies of scale – internal and external economies – Isoquants, isocost line and producer's equilibrium – Expansion path – Technical progress and its implications – Cobb-Douglas production function - Cost concepts – Social cost: private cost and external cost – Explicit and implicit cost – sunk cost - Short run cost curves - long run cost curves – Revenue (concepts) – Shutdown point – Break-even point.

Perfect and imperfect competition – monopoly, regulation of monopoly, monopolistic completion (features and equilibrium of a firm) – oligopoly – Kinked demand curve – Collusive oligopoly (meaning) – Non-price competition – Product pricing – Cost plus pricing – Target return pricing – Penetration pricing – Predatory pricing – Going rate pricing – Price skimming. Principles of taxation - Direct Tax – Indirect Tax – GST. Concepts of demonetization. Cryptocurrency



Circular flow of economic activities – Stock and flow Gross. National Income – Concepts - Methods of measuring national income – Inflation- causes and effects – Measures to control inflation. Monetary and fiscal policies – Business financing- Bonds and shares -Money market and Capital market – Stock market – Demat account and Trading account - SENSEX and NIFTY. Capital Budgeting - Methods of Investment analysis - Pay back, ARR, NPV, IRR and B/C ratio

Advantages and disadvantages of international trade - Absolute and Comparative advantage theory - Heckscher - Ohlin theory - Balance of payments – Components – Balance of Payments deficit and devaluation – Trade policy – Free trade versus protection – Tariff and non-tariff barriers

v) REFERENCE BOOKS

- 1) Gregory N Mankiw, ‘Principles of Micro Economics’, Cengage Publications 2015
- 2) Gregory N Mankiw, ‘Principles of Macro Economics’, Cengage Publications 2012
- 3) Dwivedi D.N., ‘Macro Economics’, Tata McGraw Hill, New Delhi 2018
- 4) Mithani D M, ‘Managerial Economics’, Himalaya Publishing House, Mumbai 2017
- 5) Tulsian, ‘Financial Management’ S Chand & Company 2017
- 6) Francis Cherunilam, ‘International Economics’, McGraw Hill, New Delhi 2017

vi) COURSE PLAN

Module	Contents	No. of hours
I	Scarcity and choice - Basic economic problems- PPC – Firms and its objectives – types of firms – Utility – Law of diminishing marginal utility – Demand and its determinants – law of demand – elasticity of demand – measurement of elasticity and its applications – Supply, law of supply and determinants of supply – Equilibrium – Changes in demand and supply and its effects – Consumer surplus and producer surplus (Concepts) – Taxation and deadweight loss.	8
II	Production function – law of variable proportion – economies of scale – internal and external economies – Isoquants, isocost line and producer’s equilibrium – Expansion path – Technical progress and its implications – Cobb-Douglas production function - Cost concepts – Social cost: private cost and external cost – Explicit and implicit cost – sunk cost - Short run cost curves - long run cost curves – Revenue (concepts) – Shutdown point – Break-even point.	8
III	Perfect and imperfect competition – monopoly, regulation of monopoly, monopolistic completion (features and equilibrium of a firm) – oligopoly – Kinked demand curve – Collusive oligopoly (meaning) – Non-price competition – Product pricing – Cost plus pricing – Target return pricing – Penetration pricing – Predatory pricing – Going rate pricing – Price skimming. Principles of taxation - Direct Tax – Indirect Tax – GST. Concepts of demonetization. Crypto-currency	9
IV	Circular flow of economic activities – Stock and flow Gross. National Income – Concepts - Methods of measuring national income – Inflation- causes and effects – Measures to control inflation. Monetary and fiscal policies – Business financing- Bonds and shares -Money market and Capital market – Stock market – Demat account and Trading account - SENSEX and NIFTY. Capital Budgeting - Methods of Investment	11



	analysis - Pay back, ARR, NPV, IRR and B/C ratio	
V	Advantages and disadvantages of international trade - Absolute and Comparative advantage theory - Heckscher - Ohlin theory - Balance of payments – Components – Balance of Payments deficit and devaluation – Trade policy – Free trade versus protection – Tariff and non-tariff barriers	9
	Total hours	45

vii) ASSESSMENT PATTERN**Mark distribution**

Total Marks	Continuous Internal Evaluation Marks	End Semester Evaluation Marks	End Semester Examination Duration
150	50	100	3 Hours

Continuous Internal Evaluation Pattern:

Attendance	10 Marks
Continuous Assessment Tests (2 numbers)	25 Marks
Assignment/Quiz/Course project	15 Marks

End Semester Examination Pattern:

There will be two parts; Part A and Part B. Part A contain 10 questions with 2 questions from each module, having 3 marks for each question. Students should answer all questions. Part B contains 2 questions from each module of which student should answer any one. Each question can have maximum 2 sub-divisions and carry 14 marks.



Course Code	Course Name	Category	L	T	P	Credit	Year of Introduction
HSOU30B	MANAGEMENT FOR ENGINEERS	HSC	3	0	0	3	2020

i) COURSE OVERVIEW:

Objective of the course is to learn the basic concepts and functions of management and its role in the performance of an organization and to understand various decision-making approaches available for managers to achieve excellence.

ii) COURSE OUTCOMES:

After the completion of the course, the student will be able to:

Course Outcomes	Description	Level
CO1	Explain the characteristics of management in the contemporary context	Understand
CO2	Summarize the functions of management	Understand
CO3	Infer the decision making process and productivity analysis	Understand
CO4	Demonstrate project management technique and develop a project schedule	Apply
CO5	Explain the functional areas of management and the concept of entrepreneurship	Understand

iii) SYLLABUS:

Introduction to management theory- Characteristic of Management, System approaches to Management, Task and Responsibilities of a professional Manager.

Management and organization-Management Process, Planning types, Principles of Organisation, Organisation Structures.

Productivity and decision making- Concept of productivity and its measurement; Decision making process; Decision trees; Models of decision making.

Project management- Network construction, CPM and PERT Networks, Scheduling computations, PERT time estimates, Probability of completion of project.

Functional areas of management- Operations management, Human resources management, Marketing management, Financial management, Entrepreneurship, Business plans, Corporate social responsibility, Patents and Intellectual property rights.

iv a) TEXTBOOKS

- 1) H. Koontz, and H. Weihrich, Essentials of Management: An International Perspective. 10th ed., McGraw-Hill, 2015



- 2) P. Kotler, K. L. Keller, A. Koshy, and M. Jha, Marketing Management: A South Asian Perspective. 15th ed., Pearson, 2016.
- 3) R. D. Hisrich, and M. P. Peters, Entrepreneurship: Strategy, Developing, and Managing a New Enterprise, 11th ed., McGraw-Hill Education, 2020.
- 4) M. Y. Khan, and P. K. Jain, Financial Management, Tata-McGraw Hill, 2020.

b) REFERENCES

- 1) R. B. Chase, Ravi Shankar and F. R. Jacobs, Operations and Supply Chain Management, 15th ed. McGraw Hill Education (India), 2018.
- 2) P C Tripathi and P N Reddy, Principles of management, TMH, 5th edition, 2012
- 3) K.Ashwathappa, 'Human Resources and Personnel Management', TMH, 7th edition, 2011.
D. J. Sumanth, Productivity Engineering and Management, McGraw-Hill Education, 2019
- 4)

v) COURSE PLAN

Module	Contents	No. of hours
I	Introduction to management theory, Management Defined, Characteristic of Management, Management as an art-profession, System approaches to Management, Task and Responsibilities of a professional Manager, Levels of Manager and Skill required.	8
II	Management Process, Planning types , Mission, Goals, Strategy, Programmes, Procedures, Organising, Principles of Organisation, Delegation, Span of Control, Organisation Structures, Directing, Leadership, Motivation, Controlling.	8
III	Concept of productivity and its measurement; Competitiveness; Decision making process; decision making under certainty, risk and uncertainty; Decision trees; Models of decision making	9
IV	Project Management, Network construction, Arrow diagram, Redundancy. CPM and PERT Networks, Scheduling computations, PERT time estimates, Probability of completion of project, Introduction to crashing.	10



V	Introduction to functional areas of management, Operations management, Human resources management, Marketing management, Financial management, Entrepreneurship, Business plans, Corporate social responsibility, Patents and Intellectual property rights.	10
	Total hours	45

vi) ASSESSMENT PATTERN

Mark distribution

Total Marks	Continuous Internal Evaluation Marks	End Semester Evaluation Marks	End Semester Examination Duration
150	50	100	3 Hours

Continuous Internal Evaluation Pattern:

Attendance	10 Marks
Continuous Assessment Tests (2 numbers)	25 Marks
Assignment/Quiz/Course project	15 Marks

End Semester Examination Pattern:

There will be two parts; Part A and Part B. Part A contain 10 questions with 2 questions from each module, having 3 marks for each question. Students should answer all questions. Part B contains 2 questions from each module of which student should answer any one. Each question can have maximum 2 sub-divisions and carry 14 marks.



Course Code	Course Name	Category	L	T	P	Credit	Year of Introduction
NC0U30A	DISASTER MANAGEMENT	HSC	2	0	0	Nil	2020

i) COURSE OVERVIEW

The goal of this course is to expose the students to the fundamental concepts of hazards and disaster management. The course details the various phases of disaster risk management and the measures to reduce disaster risks.

ii) COURSE OUTCOMES

After the completion of the course, the student will be able to:

Course Outcomes	Description	Level
CO 1	Explain the fundamental concepts and terminology related to disaster management cycle	Understand
CO 2	Explain hazard and vulnerability types and disaster risk assessment	Understand
CO 3	Describe the process of risk assessment and appropriate methodologies to assess risk	Understand
CO 4	Explain the core elements and phases of disaster risk management and measures to reduce disaster risks across sector and community	Apply
CO 5	Discuss the factors that determine the nature of disaster response and the various disaster response actions	Understand
CO 6	Explain the legislations and best practices for disaster management and risk reduction at national and international level	Understand

iii) SYLLABUS

Introduction- Systems of Earth, Key concepts and terminology in disaster risk reduction and management

Hazard types, Vulnerability types and their assessment, Disaster risk assessment

Disaster risk management- Phases of disaster risk management, Measures for disaster risk reduction- prevention, mitigation, preparedness, Disaster response, Relief

Participatory stakeholder engagement, Disaster communication, Capacity building

Common disaster types in India, Legislations in India on Disaster Management, National Disaster Management Policy, Institutional arrangements for disaster management in India, The Sendai Framework for Disaster risk reduction.

iv)(a) TEXT BOOKS

- 1) Coppola, D.P., *Introduction to International Disaster Management*, Elsevier Science (B/H), London, 2020
- 2) Srivastava, H.N., Gupta, G.D., *Management of Natural Disasters in developing countries*, Daya Publishers, Delhi, 2007



- 3) Subramanian, R., *Disaster Management*, Vikas Publishing House, 2018
- 4) Sulphey, M.M., *Disaster Management*, PHI Learning, 2016

(b) REFERENCES

- 1) NDMA, *National Policy on Disaster Management*, Ministry of Home Affairs, Government of India, 2009.
- 2) National Disaster Management Division, *Disaster Management in India - A Status Report*, Ministry of Home Affairs, Government of India, New Delhi, 2004.
- 3) *National Disaster Management Plan*, NDMA, Ministry of Home Affairs, Government of India, 2019.
- 4) *Disaster Management Training Manual*, UNDP, 2016
- 5) United Nations Office for Disaster Risk Reduction, *Sendai Framework for Disaster Risk Reduction 2015-2030*, 2015

v) COURSE PLAN

Module	Contents	No. of hours
I	Introduction about various systems of earth, Lithosphere- composition, rocks, soils; Atmosphere- layers, ozone layer, greenhouse effect. Weather, cyclones, atmospheric circulations, Indian monsoon; Hydrosphere- oceans, inland water bodies; Biosphere Definition and meaning of key terms in Disaster risk reduction and Management – disaster, hazard, exposure, vulnerability, risk, risk assessment, risk mapping, capacity, resilience, disaster risk reduction, disaster risk management, early warning systems, disaster preparedness, disaster prevention, disaster mitigation, disaster response, damage assessment, crisis counselling, needs assessment	6
II	Various hazard types, hazard mapping; Different types of vulnerability types and their assessment- Physical, social, economic and environmental vulnerability. Core elements of disaster risk assessment Components of a comprehensive disaster preparedness strategy approaches, procedures Different disaster response actions	6
III	Introduction to disaster risk management, core elements of disaster risk management Phases of disaster risk management, Measures for disaster risk reduction Measures for disaster prevention, mitigation, and preparedness Disaster response- objectives, requirements. Disaster response planning; types of responses Disaster relief, International relief organisations	7
IV	Participatory stakeholder engagement, Importance of disaster communication, Disaster communication- methods, barriers, Crisis counselling Introduction to capacity building, Concept- Structural measures, Non-structural measures Introduction to Capacity assessment, Capacity assessment- Strengthening, Capacity for reducing risk	5



V	Introduction- common disaster types in India Common disaster legislations in India on disaster management National disaster management policy, Institutional arrangements for disaster management in India. The Sendai Framework for Disaster risk reduction and targets- priorities for action, guiding principles	6
	Total hours	30

vi) ASSESSMENT PATTERN**Mark distribution**

Total Marks	Continuous Internal Evaluation Marks	End Semester Evaluation Marks	End Semester Examination Duration
150	50	100	3 Hours

Continuous Internal Evaluation Pattern:

Attendance	10 Marks
Continuous Assessment Tests (2 numbers)	25 Marks
Assignment/Quiz/Course project	15 Marks

End Semester Examination Pattern:

There will be two parts; Part A and Part B. Part A contain 10 questions with 2 questions from each module, having 3 marks for each question. Students should answer all questions. Part B contains 2 questions from each module of which student should answer any one. Each question can have maximum 2 sub-divisions and carry 14 marks.



Course Code	Course Name	Category	L	T	P	Credit	Year of Introduction
EC1U38A	ANALOG INTEGRATED CIRCUITS AND SIMULATION LAB	PCC	0	0	3	2	2020

i) **PREREQUISITE:** EC1U28C - Analog Circuits and Simulation Lab

ii) **COURSE OVERVIEW:**

This course aims to (i) familiarize students with the Analog Integrated Circuits and Design and implementation of application circuits using basic Analog Integrated Circuits (ii) familiarize students with simulation of basic Analog Integrated Circuits.

iii) **COURSE OUTCOMES**

After the completion of the course, the student will be able to

Course Outcomes	Description	Level
CO 1	Implement various linear circuits using op amp.	Apply
CO 2	Implement various nonlinear circuits using analog ICs	Apply
CO 3	Simulate the analog integrated circuits using simulation tool.	Apply

iv) **SYLLABUS**

Fundamentals of operational amplifiers and basic circuits

Application circuits of 555 Timer/565 PLL

Simulation experiments

v) **REFERENCES**

1. Roy D. C. and S. B. Jain, *Linear Integrated Circuits*, 5/e, New Age International, 2018.

2. M. H. Rashid, *Introduction to Pspice Using Orcad for Circuits and Electronics*, 3/e, Prentice Hall, 2003

**vi) COURSE PLAN**

Experiment No.	List of exercises/experiments	No. of hours
I	<ol style="list-style-type: none">1. Familiarization of Operational amplifiers - Inverting and Non inverting amplifiers, frequency response, Adder, Integrator, Comparators.2. Measurement of Op-Amp parameters.3. Difference Amplifier and Instrumentation amplifier.4. Schmitt trigger circuit using Op–Amps.5. Astable and Monostable multivibrator using Op-Amps.6. Wien bridge oscillator using Op-Amp - without & with amplitude stabilization.7. RC Phase shift Oscillator.8. Astable and Monostable multivibrator using Timer IC NE555.9. D/A Converters - R-2R ladder circuit.10. Study of PLL IC: free running frequency lock range capture range	36
III	Simulation experiments[The experiments shall be conducted using SPICE] <ol style="list-style-type: none">1. Astable and Monostable multivibrator using Op-Amps.2. RC Phase shift Oscillator.3. Precision rectifiers using Op-Amp.4. D/A Converters- R2R ladder circuit.	9
	Total hours	45

**vii) ASSESSMENT PATTERN****Mark distribution**

Total Marks	Continuous Internal Evaluation Marks	End Semester Evaluation Marks	End Semester Examination Duration
150	75	75	3 Hours

Continuous Internal Evaluation Pattern:

Attendance	15 Marks
Continuous Assessment	30 Marks
Internal Test (Immediately before the II internal test)	30 Marks

End Semester Examination Pattern:

Preliminary work	15 marks
Implementing the work/Conducting the experiment	20 marks
Performance, result and inference (usage of equipment and troubleshooting):	15 marks
Viva voce	20 marks
Record	5 Marks



Course Code	Course Name	Category	L	T	P	Credit	Year of Introduction
EC1U38B	DIGITAL SIGNAL PROCESSING LAB	PCC	0	0	3	2	2020

i) **PREREQUISITE:** ES0U10E - Programming in C, EC1U28A - Scientific Computing Lab, EC1U20E - Signals and Systems, EC1U30B - Digital Signal Processing

ii) **COURSE OVERVIEW**

To enable the students to explore the concepts of design, simulation and implementation of various systems using MATLAB/SciLab/OCTAVE and DSP kit.

iii) **COURSE OUTCOMES**

After the completion of the course, the student will be able to

Course Outcomes	Description	Level
CO 1	Generate digital signals using simulation tool.	Understand
CO 2	Analyse the properties of DFT using simulation tool.	Apply
CO 3	Design real time filters using DSP hardware.	Analyse
CO 4	Analyse LTI systems using convolution.	Apply
CO 5	Analyse real time signals using FFT and IFFT.	Analyze
CO 6	Analyse speech signals using FIR low pass filter	Analyse
CO 7	Design real time LTI systems with block convolution and FFT.	Analyse

iv) **SYLLABUS**

Simulation of Signals

Verification of the Properties of DFT.

Familiarization of DSP Hardware

LTI System with Linear Convolution

FFT Computation

Implementation of FIR Filter

LTI Systems by Block Convolution

**v) REFERENCES**

- 1) Vinay K. Ingle, John G. Proakis, *Digital Signal Processing Using MATLAB*.
- 2) Allen B. Downey, *Think DSP: Digital Signal Processing using Python*.
- 3) RulphChassaing, *DSP Applications Using C and the TMS320C6x DSK* (Topics in Digital Signal Processing)

vi) COURSE PLAN

Experiment No.	List of exercises/experiments	No. of hours
I	Simulation of Signals Simulate the following signals using Python/ Scilab/MATLAB. <ol style="list-style-type: none">1. Unit impulse signal2. Unit pulse signal3. Unit ramp signal4. Bipolar pulse5. Triangular signal	3
II	Verification of the Properties of DFT <ul style="list-style-type: none">• Generate and appreciate a DFT matrix.<ol style="list-style-type: none">1. Write a function that returns the N point DFT matrix VN for a given N.2. Plot its real and imaginary parts of VN as images using matshow or imshow commands (in Python) for N = 16, N = 64 and N = 10243. Compute the DFTs of 16 point, 64 point and 1024 point random sequences using the above matrices.4. Observe the time of computations for $N = 2^\gamma$ for $2 \leq \gamma \leq 18$ (You may use the time module in Python).5. Use some iterations to plot the times of computation against γ. Plot and understand this curve. Plot the times of computation for the fft function over this curve and appreciate the computational saving with FFT.• Circular Convolution.<ol style="list-style-type: none">1. Write a python function circon.py that returns the circular convolution of an N1 point sequence and an N2 point sequence given at	5



	<p>the input. The easiest way is to convert a linear convolution into circular convolution with $N = \max(N_1, N_2)$.</p> <ul style="list-style-type: none"> Parseval's Theorem <p>For the random sequences $x_1[n]$ and $x_2[n]$.</p> $\sum_{n=0}^{N-1} x_1[n]x_2^*[n] = \frac{1}{N} \sum_{k=0}^{N-1} X_1[k]X_2^*[k]$ <ol style="list-style-type: none"> 1. Generate two random complex sequences of say 5000 values. 2. Prove the theorem for these signals. 	
<p>III</p>	<p>3. Familiarization of DSP Hardware</p> <ol style="list-style-type: none"> 1. Familiarization of the code composer studio (in the case of TI hardware) or Visual DSP (in the case of Analog Devices hardware) or any equivalent cross compiler for DSP programming. 2. Familiarization of the analog and digital input and output ports of the DSP board. 3. Generation and cross compilation and execution of the C code to connect the input digital switches to the output LEDs. 4. Generation and cross compilation and execution of the C code to connect the input analog port to the output. Connect a microphone, speak into it and observe the output electrical signal on a DSO and store it. 5. Document the work. 	<p>5</p>
<p>IV</p>	<p>Linear convolution</p> <ol style="list-style-type: none"> 1. Write a C function for the linear convolution of two arrays. 2. The arrays may be kept in different files and downloaded to the DSP hardware. 3. Store the result as a file and observe the output. 4. Document the work. 	<p>3</p>
<p>V</p>	<p>FFT of signals</p> <ol style="list-style-type: none"> 1. Write a C function for N - point FFT. 2. Connect a precision signal generator and apply 1 mV , 1 kHz sinusoid at the analog port. 3. Apply the FFT on the input signal with appropriate window size and observe the result. 4. Connect microphone to the analog port and read in real time speech. 	<p>6</p>

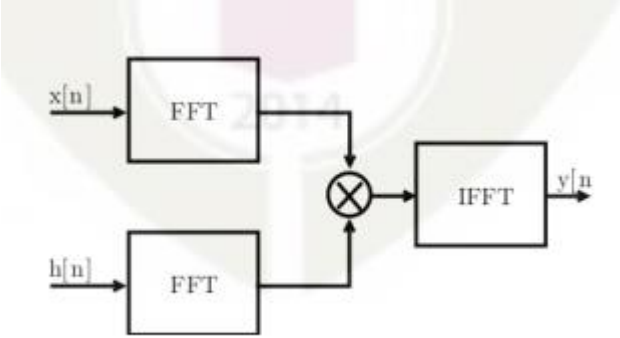

	<p>5. Observe and store the FFT values.</p> <p>6. Document the work.</p>	
VI	<p>IFFT with FFT</p> <p>1. Use the FFT function in the previous experiment to compute the IFFT of the input signal.</p> <p>2. Apply IFFT on the stored FFT values from the previous experiments and observe the reconstruction.</p> <p>3. Document the work.</p>	6
VII	<p>FIR low pass filter</p> <p>1. Use Python/scilab to implement the FIR filter $response\ h[n] = \frac{\sin(\omega cn)}{\pi n}$ for a filter size $N = 50$, $\omega c = 0.1\pi$ and $\omega c = 0.3\pi$.</p> <p>2. Realize the hamming($w_H[n]$) and kaiser ($w_K[n]$) windows.</p> <p>3. Compute $h[n]w[n]$ in both cases and store as file.</p> <p>4. Observe the low pass response in the simulator.</p> <p>5. Download the filter on to the DSP target board and test with 1 mV sinusoid from a signal generator connected to the analog port.</p> <p>6. Test the operation of the filters with speech signals.</p> <p>7. Document the work.</p>	6
VIII	<p>Overlap Save Block Convolution</p> <p>1. Use the file of filter coefficients From the previos experiment.</p> <p>2. Realize the system shown below for the input speech signal $x[n]$.</p>  <p>3. Segment the signal values into blocks of length $N = 2000$. Pad the last block with zeros, if necessary.</p> <p>4. Implement the overlap save block convolution method</p> <p>5. Document the work.</p>	6



IX	<p>Overlap Add Block Convolution</p> <ol style="list-style-type: none"> 1. Use the file of filter coefficients from the previous experiment. 2. Realize the system shown in the previous experiment for the input speech signal $x[n]$. 3. Segment the signal values into blocks of length $N = 2000$. Pad the last block with zeros, if necessary. 4. Implement the overlap add block convolution method 5. Document the work. 	5
	Total hours	45

vii) ASSESSMENT PATTERN**Mark distribution**

Total Marks	Continuous Internal Evaluation Marks	End Semester Evaluation Marks	End Semester Examination Duration
150	75	75	3 Hours

Continuous Internal Evaluation Pattern:

Attendance	15 Marks
Continuous Assessment	30 Marks
Internal Test (Immediately before the II internal test)	30 Marks

End Semester Examination Pattern:

Preliminary work	15 marks
Implementing the work/Conducting the experiment	20 marks
Performance, result and inference (usage of equipment and troubleshooting):	15 marks
Viva voce	20 marks
Record	5 Marks



MINORS



Course Code	Course Name	Category	L	T	P	Credit	Year of Introduction
ECOM30A	EMBEDDED SYSTEM DESIGN	VAC (MINOR)	3	1	0	4	2020

i) **PREREQUISITE:** EC1U20B - Logic Circuit Design, EC1U20F - Computer Architecture and Microcontrollers

ii) COURSE OVERVIEW

Goal of this course is to introduce embedded systems, various protocols used for communication between peripheral devices and processor, Embedded programming, the ARM processor organization and programming, and the basic concepts of real time operating systems.

iii) COURSE OUTCOMES

After the completion of the course, the student will be able to

Course Outcomes	Description	Level
CO 1	Discuss the basic concepts of embedded systems and different phases in the embedded system design process/EDLC.	Understand
CO 2	Describe the peripheral devices and their interfacing with the processor.	Understand
CO 3	Prepare the programs using high-level languages for embedded systems.	Apply
CO 4	Explain the ARM processor architecture and pipeline processor organization. .	Understand
CO 5	Prepare programs in assembly and highlevel languages for ARM processor	Apply

iv) SYLLABUS

Introduction to Embedded Systems:

Complex Systems and Microprocessors, The Embedded System Design Process, Formalisms for System Design , Embedded product development cycle (EDLC).

Embedded system interfacing and peripherals:

Serial Communication Standards and Devices, Serial Bus Protocols, Parallel communication standards, Memory, DMA, I/O Device- Interrupts.

Embedded Programming:

Programming languages, Embedded C programming.

ARM Processor fundamentals:

ARM Processor architecture, ARM Assembly Language Programming, ARM Organization and Implementation.

ARM Programming:

Architectural Support for High Level Languages, The Thumb Instruction Set , Architectural Support for System Development- The ARM memory interface, The Advanced Microcontroller Bus Architecture (AMBA).

**v) a) TEXT BOOKS**

- 1) K.V. Shibu, *Introduction to Embedded Systems*, 2e, McGraw Hill Education India, 2016.
- 2) Wayne Wolf, *Computers as Components: Principles of Embedded Computing System Design*, Morgan Kaufman Publishers - Elsevier 3e, 2008.
- 3) Steve Furber, *ARM system-on-chip architecture*, Addison Wesley, Second Edition, 2000.
- 4) Raj Kamal, *Embedded Systems Architecture, Programming and Design*, TMH, Third Edition, 2017.

b) REFERENCES

- 1) David E. Simon, *An Embedded Software Primer*, First Indian Reprint, Pearson Education Asia, 2000.
- 2) Steve Heath, *Embedded Systems Design*, Newnes – Elsevier 2/ed, 2002.
- 3) Andrew N. Sloss, Dominic Symes, Chris Wright, *ARM System Developer's Guide Designing Optimizing System Software*, Morgan Kaufmann Publishers, 2004
- 4) Frank Vahid and Tony Givargis, *Embedded Systems Design – A Unified Hardware /Software Introduction*, John Wiley, 2002.
- 5) Tammy Noergaard, *Embedded Systems Architecture, A Comprehensive Guide for Engineers and Programmers*, Newnes – Elsevier 2/ed, 2013.
- 6) Iyer - *Embedded Real time Systems*, 1/e, McGraw Hill Education New Delhi, 2003
- 7) Lyla B. Das, *Embedded Systems: An Integrated Approach*, 1/e, 2012.
- 8) Sarmad Naimi, Muhammad Ali Mazidi, Sepehr Naimi, *The STM32F103 Arm Microcontroller and Embedded Systems: Using Assembly and C*, MicroDigitalEd., 2020
- 9) Shujen Chen, Muhammad Ali Mazidi, Eshragh Ghaemi, *STM32 Arm Programming for Embedded Systems*, 2018.

vi) COURSE PLAN

Module	Contents	No. of hours
I	Complex Systems and Microprocessors: Embedding Computers, Characteristics of Embedded Computing Applications, Application of Microprocessors, The Physics of Software, Challenges in Embedded Computing System, Characteristics and quality attributes of an embedded system, Performance in Embedded Computing. The Embedded System Design Process: Requirements, Specification, Architecture Design, Designing Hardware and Software Components and System Integration. Formalisms for System Design: Structural Description, Behavioral Description, An embedded system design example. Embedded product development cycle (EDLC): Different phases of EDLC and EDLC models	11
II	Communication devices: Serial Communication Standards and Devices - UART, HDLC and SPI. Serial Bus Protocols - I 2C Bus, CAN Bus and USB Bus, Parallel communication standards-ISA, PCI and PCI-X Bus. Memory: Memory devices and systems:- ROM-Flash, EEPROM: RAM-SRAM, DRAM, Cache memory, memory mapping and addresses, memory management unit- DMA. I/O Device: Interrupts:-Interrupt sources, recognizing an interrupt, ISR – Device drivers for handling ISR, Interrupt latency.	12



III	Programming languages: -Assembly Languages, High level languages, Embedded C, Object oriented programming, C++, JAVA. Embedded C programming: Keywords and Identifiers, Data Types, Storage Class, operators, branching, looping, arrays, pointers, characters, strings, functions, function pointers, structures, unions, pre-processors and macros, constant declaration, volatile type qualifier, delay generation, infinite loops, bit manipulation, ISR, direct memory allocation	13
IV	ARM Processor architecture: The Acorn RISC Machine- Architectural inheritance, The ARM programmer's model, ARM development tools. ARM Assembly Language Programming: Data processing instructions, Data transfer instructions, Control flow instructions, writing simple assembly language programs. ARM Organization and Implementation: 3 stage pipeline ARM organization, 5-stage pipeline ARM organization, ARM instruction execution, ARM implementation, The ARM coprocessor interface	12
V	Architectural Support for High Level Languages: Abstraction in software design, Data types, Floating-point data types, The ARM floating-point architecture, Expressions, Conditional statements, Loops, Functions and procedures, Use of memory, Run-time environment. The Thumb Instruction Set: The Thumb bit in the CPSR, The Thumb programmer's model, Thumb branch instructions, Thumb software interrupt instruction, Thumb data processing instructions, Thumb single register data transfer instructions, Thumb multiple register data transfer instructions, Thumb breakpoint instruction, Thumb implementation, Thumb applications. Architectural Support for System Development: The ARM memory interface, The Advanced Microcontroller Bus Architecture (AMBA).	12
	Total hours	60

Simulation Assignments

- At least one assignment should be of programming (Both assembly and C languages) of embedded processor with simulation tools like Keil, Eclipse.
- Another assignment should be an embedded system design mini project like, Programming assignments can be the following. a) Print "HELLO WORLD" or any text, b)Data transfer, copy operations c)Arithmetic operations d)Sorting operations, e)Input/output control, f)Programs using functions, g) Interrupts and ISR h) controller design
- Mini project can be done in the following areas. a) Elevator controller design (b) Chocolate vending machine design (c) Industrial controller using sensors (d) IOT applications using sensors, communication devices and actuators

**vii) ASSESSMENT PATTERN****Mark distribution**

Total Marks	Continuous Internal Evaluation Marks	End Semester Evaluation Marks	End Semester Examination Duration
150	50	100	3 Hours

Continuous Internal Evaluation Pattern:

Attendance	10 Marks
Continuous Assessment Tests (2 numbers)	25 Marks
Assignment/Quiz/Course project	15 Marks

End Semester Examination Pattern:

There will be two parts; Part A and Part B. Part A contain 10 questions with 2 questions from each module, having 3 marks for each question. Students should answer all questions. Part B contains 2 questions from each module of which student should answer any one. Each question can have maximum 2 sub-divisions and carry 14 marks.



Course Code	Course Name	Category	L	T	P	Credit	Year of Introduction
ECOM30B	COMMUNICATION SYSTEMS	VAC (MINOR)	4	0	0	4	2020

i) COURSE OVERVIEW

The goal of this course to give awareness about various communication systems using in real life.

ii) COURSE OUTCOMES

After the completion of the course, the student will be able to

Course Outcomes	Description	Level
CO 1	Explain the components required for an Optical Communication Systems	Understand
CO 2	Discuss the principle involved in RADAR and Navigation	Understand
CO 3	Explain the concept and subsystems for Cellular Communication networks	Understand
CO 4	Describe the requirement for Satellite communication systems	Understand
CO 5	Discuss the role of different layers in TCP/IP protocol stack in communication networks	Understand

iii) SYLLABUS

Optical Communication System – Block Diagram – Advantages Of Optical Fiber Communication Systems – Principles Of Light Transmission in a Fiber using Ray Theory – Types of Fibers, Attenuation in Optical Fibers, Optical transmitters: LED and semiconductor LASER, characteristics, transmitter design. Optical receivers: Common photo detectors. Receiver design.

Basic Radar System– Applications – Radar Range Equation (Qualitative Treatment Only) – Factors Influencing Maximum Range – Basic Pulsed Radar System – Block Diagram – Display Methods- A - Scope, PPI Display - Instrument Landing System – Ground Controlled Approach System.

Cellular Communication, Hand off, Frequency Reuse, Principles of Multicarrier communication, Multiple Access techniques, CDMA Systems: General aspects of CDMA cellular systems, IS-95 standard, Downlink and uplink, GSM standard and service aspects – GSM architecture, Evolution to Third Generation systems, WCDMA and CDMA-2000 standards, 4G, 5G

Basic concept of satellite communication, Kepler's law, Satellite orbits, Geosynchronous satellites, Active and Passive satellite, Block diagram for Satellite uplink, Transponder and earth station receiver.

Study of OSI and TCP/IP protocol suit: The Model, Functions of each layer, TCP/IP Protocol Suites. Wireless Ad Hoc Networks: Issues and Challenges, Wireless Sensor Networks: Architecture, Data dissemination, Data gathering, MAC Protocols, Location discovery, Quality of a sensor network 6LoWPAN

**iv)a) TEXT BOOKS**

- 1) Wayne Tomasi, *Electronic communication system fundamentals*, 5/e, Pearson Education, Jan 2008
- 2) Behrouz A. Forouzan, *Data Communication and Networking*, 4/e, Tata McGraw Hill

b) REFERENCES

- 1) T S Rappaport, *Wireless communication principles and practice*, 2e/d, Pearson Education, 2002
- 2) G. E. Keiser, *Optical Fibre Communication*, McGraw Hill Publication.
- 3) D. C. Agarwal, *Satellite Communication*, Khanna Publications, 1989.
- 4) Jochen Schiller, *Mobile Communications*, 2e/d, Pearson Education, 2008.
- 5) Siva ram Murthy, B S Manoj, *Ad Hoc Wireless Networks*, Printice Hall, 2004.

v) COURSE PLAN

Module	Contents	No. of hours
I	Optical Communication System – Block Diagram – Advantages Of Optical Fiber Communication Systems – Principles Of Light Transmission In A Fiber Using Ray Theory – Single Mode Fibers, Multimode Fibers – Step Index Fibers, Graded Index Fibers (Basic Concepts Only) – Attenuation In Optical Fibers – Absorption Losses, Scattering Losses, Bending Losses, Core And Cladding Losses. Optical transmitters: LED and semiconductor LASER, characteristics, transmitter design. Optical receivers: Common photo detectors. Receiver design	11
II	Basic Radar System– Applications – Radar Range Equation (Qualitative Treatment Only) – Factors Influencing Maximum Range – Basic Pulsed Radar System – Block Diagram – Display MethodsA - Scope, PPI Display, Instrument Landing System – Ground Controlled Approach System	11
III	Cellular Communication, Hand off, Frequency Reuse, Principles of Multicarrier communication, Multiple Access techniques, CDMA Systems: General aspects of CDMA cellular systems, IS-95 standard, Downlink and uplink, GSM standard and service aspects – GSM architecture, Evolution to Third Generation systems, WCDMA and CDMA-2000 standards,4G, 5G	12
IV	Basic concept of satellite communication, Kepler's law, Satellite orbits, Geosynchronous satellites, Active and Passive satellite, Block diagram for Satellite uplink, Transponder and earth station receiver	13
V	Study of OSI and TCP/IP protocol suit: The Model, Functions of each layer, TCP/IP Protocol Suites, Issues and challenges in Wireless Ad Hoc Networks, Vehicular Ad Hoc Networks, Wireless Sensor Networks: Architecture, Data dissemination, Data gathering, MAC Protocols, Location discovery, Quality of a sensor network, 6LoWPAN	13
	Total hours	60

**vi) ASSESSMENT PATTERN****Mark distribution**

Total Marks	Continuous Internal Evaluation Marks	End Semester Evaluation Marks	End Semester Examination Duration
150	50	100	3 Hours

Continuous Internal Evaluation Pattern:

Attendance	10 Marks
Continuous Assessment Tests (2 numbers)	25 Marks
Assignment/Quiz/Course project	15 Marks

End Semester Examination Pattern:

There will be two parts; Part A and Part B. Part A contain 10 questions with 2 questions from each module, having 3 marks for each question. Students should answer all questions. Part B contains 2 questions from each module of which student should answer any one. Each question can have maximum 2 sub-divisions and carry 14 marks.



Course Code	Course Name	Category	L	T	P	Credit	Year of Introduction
ECOM30C	TOPICS IN DIGITAL IMAGE PROCESSING	VAC (MINOR)	3	1	0	4	2020

i) **PREREQUISITE:** ECOM20F - Introduction to Digital Signal Processing

ii) **COURSE OVERVIEW:**

This course aims to develop the skills for methods of various transformation and analysis of image enhancement, image reconstruction, image compression, image segmentation and image representation.

iii) **COURSE OUTCOMES**

After the completion of the course, the student will be able to

Course Outcomes	Description	Level
CO 1	Explain the various basic concepts of digital image processing	Understand
CO 2	Apply the concepts to analyse a 2D discrete signal in time and frequency domain	Apply
CO 3	Explain two-dimensional sampling and quantization	Understand
CO 4	Apply the concepts to enhance and restore digital images using various filtering techniques	Apply
CO 5	Explain various image compression techniques	Understand

iv) **SYLLABUS**

Digital Image Fundamentals-Elements of visual perception, image sensing and acquisition, image sampling and quantization, basic relationships between pixels – neighbourhood, adjacency, connectivity, distance measures. Brightness, contrast, hue, saturation, mach band effect, Colour image fundamentals-RGB, CMY, HIS models, 2D sampling, quantization.

Image Enhancement: Spatial domain methods: point processing-intensity transformations, histogram processing, image subtraction, image averaging, geometric transformation Sharpening filters – first and second derivative, two-dimensional DFT and its inverse, frequency domain filters – low-pass and high-pass.

Image segmentation: Classification of Image segmentation techniques, region approach, clustering techniques Classification of edges, edge detection, Hough transform, active contour Thresholding – global and adaptive

Image restoration: Restoration Models, Linear Filtering Techniques: Inverse and Wiener, Non-linear filtering: Mean, Median, Max and Min filters Noise Models: Gaussian, Uniform, Additive, Impulse Image restoration applications

Image Compression- Need for compression, redundancy, classification of image compression schemes, Huffman coding, arithmetic coding Redundancy–inter-pixel and psycho-visual; Lossless compression – predictive, entropy; Lossy compression- predictive and transform coding – DST, DCT, wavelet transform (basics only); Still image compression standards – JPEG and JPEG-2000.

**v) a) TEXT BOOKS**

- 1) Farid Gonzalez Rafel C., *Digital Image Processing*, 3/e, Pearson Education, 2017
- 2) S. Jayaraman, S. Esakkirajan, T. Veerakumar, *Digital image processing*, Tata McGraw Hill, 2015

b) REFERENCES

- 1) Jain Anil K, *Fundamentals of digital image processing*, PHI, US edition, 1988
- 2) Kenneth R Castleman, *Digital image processing*, 2/e, Pearson Education, 2003
- 3) Pratt William K, *Digital Image Processing*, 4/e, John Wiley, 2007

vi) COURSE PLAN

Module	Contents	No. of hours
I	Digital Image Fundamentals-Elements of visual perception, image sensing and acquisition, Image sampling and quantization, basic relationships between pixels – neighbourhood, adjacency, connectivity, distance measures, Brightness, contrast, hue, saturation, mach band effect, Impulse response and its relation with transfer function of linear systems. Block diagram representation and reduction methods, 2D sampling, quantization	12
II	Image Enhancement: Spatial domain intensity transformations, Histogram processing, image subtraction, image averaging, geometric transformations, Sharpening filters, First and second derivative, two-dimensional DFT and its inverse, frequency domain filters – low-pass and high-pass.	12
III	Image segmentation: Spatial domain methods: point processing-intensity transformations, Classification of Image segmentation techniques, region approach, clustering techniques, Classification of edges, edge detection, Hough transform, active contour, Thresholding – global and adaptive.	12
IV	Image Restoration: Restoration Models -Noise Models: Gaussian, Uniform, Additive, Impulse and Erlang, Linear Filtering Techniques: Inverse and Wiener, Non-linear filtering: Mean, Median, Max and Min filters, Applications of Image restoration	12
V	Image Compression: Need for compression, redundancy, classification of image compression schemes, Huffman coding, arithmetic coding, Redundancy–inter-pixel and psycho-visual, Lossless compression – predictive, entropy, Lossy compression- predictive and transform coding DST, wavelet, Still image compression standards – JPEG and JPEG2000	12
	Total hours	60

**vii) ASSESSMENT PATTERN****Mark distribution**

Total Marks	Continuous Internal Evaluation Marks	End Semester Evaluation Marks	End Semester Examination Duration
150	50	100	3 Hours

Continuous Internal Evaluation Pattern:

Attendance	10 Marks
Continuous Assessment Tests (2 numbers)	25 Marks
Assignment/Quiz/Course project	15 Marks

End Semester Examination Pattern:

There will be two parts; Part A and Part B. Part A contain 10 questions with 2 questions from each module, having 3 marks for each question. Students should answer all questions. Part B contains 2 questions from each module of which student should answer any one. Each question can have maximum 2 sub-divisions and carry 14 marks.



HONOURS



Course Code	Course Name	Category	L	T	P	Credit	Year of Introduction
EC1H30A	FPGA BASED SYSTEM DESIGN	VAC (HONOUR)	4	0	0	4	2020

i) **PREREQUISITE:** EC1U20B - Logic Circuit Design

ii) **COURSE OVERVIEW**

Goal of this course is to develop the skill for designing digital systems using FPGA.

iii) **COURSE OUTCOMES**

After the completion of the course, the student will be able to

Course Outcomes	Description	Level
CO 1	Design simple digital systems using programmable logic devices	Apply
CO 2	Describe the architecture and characteristics of FPGA	Understand
CO 3	Discuss the design considerations of FPGA	Understand
CO 4	Design simple combinational and sequential circuits using FPGA	Apply

iv) **SYLLABUS**

Introduction: Digital system design options and tradeoffs, Design methodology, High Level System Architecture and Specification, Hardware description languages (emphasis on Verilog), State machine design, Test benches.

Programmable Logic Devices: ROM, PLA, PAL, CPLD, FPGA, Implementation of MSI circuits using PLDs.

FPGA Architecture: FPGA Architectural options, granularity of function and wiring resources, coarse V/s fine grained, vendor specific issues (emphasis on Xilinx and Altera), Logic block architecture, Timing models, Power dissipation, I/O block architecture.

Placement and Routing: Programmable interconnect, Routing resources. Embedded system design using FPGAs, DSP using FPGAs.

Commercial FPGAs: Xilinx, Altera, Actel. Case study and implementation of circuits using Xilinx Virtex.

v) a) **TEXT BOOKS**

- 1) Wayne Wolf, *FPGA-Based System Design*, Prentice Hall Modern Semiconductor Design Series, Pearson, 2004
- 2) Wayne Wolf, *Modern VLSI Design: System-on-Chip Design*, 3rd Edition, Pearson, 2002
- 3) Samir Palnikar, *Verilog HDL: A Guide to Digital Design and Synthesis*, 2nd edition, Prentice Hall, 2003

**b) REFERENCES**

- 1) S.Trimberger, Edr., *Field Programmable Gate Array Technology*, Kluwer Academic Publications, 1994
- 2) P.K.Chan& S. Mourad, *Digital Design Using Field Programmable Gate Array* , Prentice Hall (Pte), 1994
- 3) S.Brown, R.Francis, J.Rose, Z.Vransic, *Field Programmable Gate Array*, Kluwer Publications, 2007

vi) COURSE PLAN

Module	Contents	No. of hours
I	Introduction: Digital system design options and tradeoffs, Design methodology and technology overview, High Level System Architecture and Specification: Behavioural modelling and simulation, Hardware description languages, combinational and sequential design, State machine design, synthesis issues, test benches	14
II	Programmable Logic Devices: ROM, PLA, PAL, CPLD, FPGA Features, Limitations, Architectures and Programming. Implementation of MSI circuits using Programmable logic Devices.	13
III	FPGA Architecture: FPGA Architectural options, Granularity of function and wiring resources, coarse V/s fine grained, vendor specific issues (emphasis on Xilinx and Altera), Logic block architecture: FPGA logic cells, timing models, power dissipation, I/O block architecture: Input and Output cell characteristics, clock input, Timing, Power dissipation.	10
IV	Placement and Routing: Programmable interconnect - Partitioning and Placement, Routing resources, delays. Applications - Embedded system design using FPGAs, DSP using FPGAs	10
V	Commercial FPGAs: Xilinx, Altera, Actel (Different series description only). Case study: Xilinx Virtex - Implementation of simple combinational and sequential circuits	13
	Total hours	60

**vii) ASSESSMENT PATTERN****Mark distribution**

Total Marks	Continuous Internal Evaluation Marks	End Semester Evaluation Marks	End Semester Examination Duration
150	50	100	3 Hours

Continuous Internal Evaluation Pattern:

Attendance	10 Marks
Continuous Assessment Tests (2 numbers)	25 Marks
Assignment/Quiz/Course project	15 Marks

End Semester Examination Pattern:

There will be two parts; Part A and Part B. Part A contain 10 questions with 2 questions from each module, having 3 marks for each question. Students should answer all questions. Part B contains 2 questions from each module of which student should answer any one. Each question can have maximum 2 sub-divisions and carry 14 marks.



Course Code	Course Name	Category	L	T	P	Credit	Year of Introduction
EC1H30B	DETECTION AND ESTIMATION THEORY	VAC (HONOUR)	3	1	0	4	2020

i) **PREREQUISITE:** MA0U10A - Linear Algebra and Calculus, MA0U20C - Probability, Random Process, and Numerical Methods, ECT 204 - Signals and Systems

ii) **COURSE OVERVIEW**

Goal of this course is to provide an insight into the fundamentals of detection and estimation theory in engineering applications.

iii) **COURSE OUTCOMES**

After the completion of the course, the student will be able to

Course Outcomes	Description	Level
CO 1	Describe the fundamentals of statistical detection and estimation principles used in various engineering problems	Understand
CO 2	Apply various types of statistical decision rules in engineering applications.	Apply
CO 3	Apply different types of estimation methods in engineering applications.	Apply

iv) **SYLLABUS**

Fundamentals of detection and estimation theory and its applications, classical and Bayesian approach in detection and estimation theory, different types of statistical decision rules, different types of estimation algorithms and its applications.

v) a) **TEXT BOOKS**

1. S.M. Kay, *Fundamentals of Statistical Signal Processing, Vol I: Estimation Theory*, 3/e, Pearson, 2010.
2. S.M. Kay, *Fundamentals of Statistical Signal Processing Vol II: Detection Theory*, 3/e, Pearson, 2010.

**b) REFERENCES**

1. H. L. Van Trees, *Detection, Estimation, and Modulation Theory*, Vol. I, John Wiley & Sons, 1968
2. Monson H. Hayes, *Statistical Digital Signal Processing and Modelling*, John Wiley & Sons, 2002.

vi) COURSE PLAN

Module	Contents	No. of hours
I	Fundamentals of detection theory, the mathematical detection problem. Fundamentals of estimation theory, the mathematical estimation problem. Review of Gaussian distribution. Application examples.	11
II	Hypothesis testing, classical approach, Neyman-Pearson theorem, likelihood ratio test, receiver operating characteristics, Bayesian approach, minimum probability of error, Bayes risk, multiple hypothesis testing.	13
III	Detection of deterministic signals, matched filters, detection of random signals, estimator-correlator, linear model, application examples.	11
IV	Minimum variance unbiased estimation, basics of Cramer-Rao Lower Bound, linear models, best linear unbiased estimation, application examples.	13
V	Maximum likelihood estimation, least squares, Bayesian philosophy, minimum mean square error estimation, application examples.	12
	Total hours	60

**vii) ASSESSMENT PATTERN****Mark distribution**

Total Marks	Continuous Internal Evaluation Marks	End Semester Evaluation Marks	End Semester Examination Duration
150	50	100	3 Hours

Continuous Internal Evaluation Pattern:

Attendance	10 Marks
Continuous Assessment Tests (2 numbers)	25 Marks
Assignment/Quiz/Course project	15 Marks

End Semester Examination Pattern:

There will be two parts; Part A and Part B. Part A contain 10 questions with 2 questions from each module, having 3 marks for each question. Students should answer all questions. Part B contains 2 questions from each module of which student should answer any one. Each question can have maximum 2 sub-divisions and carry 14 marks.



Course Code	Course Name	Category	L	T	P	Credit	Year of Introduction
EC1H30C	COMPUTATIONAL TOOLS FOR SIGNAL PROCESSING	VAC (HONOUR)	3	1	0	4	2020

i) **PREREQUISITE:** EC1U28A - Scientific Computing Lab, EC1U20E - Signals and Systems, EC1U30B - Digital Signal Processing

ii) **COURSE OVERVIEW**

This course aims to use the computational tools in signal processing to solve industry problems.

iii) **COURSE OUTCOMES**

After the completion of the course, the student will be able to

Course Outcomes	Description	Level
CO 1	Explain different computational tools used for signal processing	Understand
CO 2	Analyse regression and Bayesian models using pymc3	Analyse
CO 3	Apply the concept to analyse different statistical models for signal processing	Apply
CO 4	Implement Kalman filters	Analyse
CO 5	Implement particle filters for practical applications	Analyse

iv) **SYLLABUS**

Statistical Modelling using pymc3, Probability concepts, Bayes theorem, Bayesian Statistics and modelling, Modelling Coin flipping as Bayesian, Choosing the likelihood and prior, Posterior computation, Posterior predictive analysis, Posterior plots. Likelihood theory and Estimation.

Modelling Linear Regression, Polynomial Regression, Multiple Linear Regression, Logistic Regression, Poisson Regression using pymc3.

Bayesian analysis using pymc3, Posterior predictive checks, Model specifications using pymc3, Examples of Bayesian Analytics. Bayes factor, Sequential Monte Carlo to compute Bayes factors, Recursive state estimation, Modelling functions using pymc3, Covariance functions and kernels, Bayesian Regression Models.

GH filter, Choosing G and H factors, Simple simulation models using GH filters, Discrete Bayes Filter for predicting the random movement, Recursive estimation and prediction, Effect of noisy environment. Kalman filter- updation using measurements and observations, Kalman Gain calculation and Prediction, Process noise and Measurement noise. Kalman Filter Equations implementation in python.

Multivariate Kalman Filter-Modelling and Designing, Effect of Nonlinearity, Nonlinear Filters, Smoothing, Adaptive Filtering. Markov concepts, Monte Carlo integration, Basics of Markov



chain Monte Carlo, Implementation using filterpy module. Particle Filter algorithm and Implementation.

v) a) TEXT BOOKS AND REFERENCES

- 1) Osvaldo Martin, *Bayesian Analysis with python*, 2/e, PACKT Open Source Publishing, 2018
- 2) SergiosTheodoridis, *Machine Learning: A Bayesian and Optimization Perspective*, 2/e, Academic Press, 2020
- 3) <https://github.com/rllabbe/Kalman-and-Bayesian-Filters-in-Python>
- 4) CyrilleRossant, *Ipython Interactive Computing and Visualization Cookbook*, 2/e, PACKT Open Source Publishing, 2018
- 5) JamesV. Candy, *Bayesian, Signal Processing: Classical, Modern, and Particle Filtering Methods*, 2/e, Wiley-IEEE Press, 2016

vi) COURSE PLAN

Module	Contents	No. of hours
I	Probabilistic Programming: Statistical Modelling using pymc3, Probability concepts, Bayes theorem, Bayesian Statistics and modelling, Modelling Coin flipping as Bayesian, Choosing the likelihood and prior, Posterior computation, Posterior predictive analysis, Posterior plots. Likelihood theory and Estimation	12
II	Modelling Linear and Logistic Regression: Modelling Linear Regression, Polynomial Regression, Multiple Linear Regression, Logistic Regression, Poisson Regression using pymc3.	12
III	Bayesian Modelling: Bayesian analysis using pymc3, Posterior predictive checks, Model specifications using pymc3, Examples of Bayesian Analytics, Bayes factor, Sequential Monte carlo to compute Bayes factors, Recursive state estimation, Modeling functions using pymc3, Covariance functions and kernels. Bayesian Regression Models	12
IV	GH and Kalman Filter: GH filter, Choosing G and H factors, Simple simulation models using GH filters, Discrete Bayes Filter for predicting the random movement, Recursive estimation and prediction, Effect of noisy environment, Kalman filter- updation using measurements and observations, Kalman Gain calculation and Prediction, Process noise and Measurement noise. Kalman Filter Equations implementation in python.	12
V	Particle Filter: Multivariate Kalman Filter - Modelling and Designing, Effect of Nonlinearity, Nonlinear Filters, Smoothing, Adaptive Filtering, Markov concepts, Monte carlo integration, Basics of Markov chain Monte Carlo, Implementation using filterpy module. Particle Filter algorithm and Implementation.	12
	Total hours	60



SIMULATION ASSIGNMENTS

- 1) Create a noisy measurement system. Design a g-h filter to filter out the noise and plot it. Write a code to filter 100 data points that starts at 5, has a derivative of 2, a noise scaling factor of 10, and uses $g=0.2$ and $h=0.02$. Set your initial guess for x to be 100.
- 2) Design a filter to track the position of a train. Its position is expressed as its position on the track in relation to some fixed point which we say is 0 km. I.e., a position of 1 means that the train is 1 km away from the fixed point. Velocity is expressed as meters per second. Measurement of position is done once per second, and the error is ± 500 meters. The train is currently at 23 kilometers, moving at 15 m/s, accelerating at 0.2 m/sec^2 . Plot the results.
- 3) Using Discrete Bayes Filter, predict the movement of a dog. The current position of the dog is 17 m. The epoch is 2 seconds long, and the dog is traveling at 15 m/s. Where will the dog be in two seconds?
- 4) Compute the statistics of a Gaussian function using `filterpy()` module
- 5) Design a Kalman filter to track the movement of a dog (parameters same as previous one) in a Noisy environment
- 6) Prove that the binomial and beta distributions are conjugate pairs with respect to the mean value.
- 7) Show that the conjugate prior of the multivariate Gaussian with respect to the precision matrix, Q , is a Wishart distribution.
- 8) Prove that if a probability distribution p satisfies the Markov condition, as implied by a BN, then p is given as the product of the conditional distributions given the values of the parents.
- 9) Suppose that n balls are thrown independently and uniformly at random into n bins.
 - a. Find the conditional probability that bin 1 has one ball given that exactly one ball fell into the first three bins.
 - b. Find the conditional expectation of the number of balls in bin 1 under the condition that bin 2 received no balls
 - c. Write an expression for the probability that bin 1 receives more balls than bin 2.

**vii) ASSESSMENT PATTERN****Mark distribution**

Total Marks	Continuous Internal Evaluation Marks	End Semester Evaluation Marks	End Semester Examination Duration
150	50	100	3 Hours

Continuous Internal Evaluation Pattern:

Attendance	10 Marks
Continuous Assessment Tests (2 numbers)	25 Marks
Assignment/Quiz/Course project	15 Marks

End Semester Examination Pattern:

There will be two parts; Part A and Part B. Part A contain 10 questions with 2 questions from each module, having 3 marks for each question. Students should answer all questions. Part B contains 2 questions from each module of which student should answer any one. Each question can have maximum 2 sub-divisions and carry 14 marks.



SEMESTER VI



Course Code	Course Name	Category	L	T	P	Credit	Year of Introduction
EC1U30E	ELECTROMAGNETICS	PCC	3	1	0	4	2020

i) **PREREQUISITE:** MA0U10B - Vector Calculus

ii) **COURSE OVERVIEW**

This course aims to impart knowledge on the basic concepts of electric and magnetic fields and its applications.

iii) **COURSE OUTCOMES**

After the completion of the course, the student will be able to

Course Outcomes	Description	Level
CO 1	Summarize the basic mathematical concepts related to electromagnetic vector fields.	Apply
CO 2	Apply Maxwell's equation to engineering problems.	Analyse
CO 3	Analyse electromagnetic wave propagation and wave polarization in different media.	Analyse
CO 4	Analyse the parameters of transmission lines using Smith chart.	Analyse
CO 5	Analyse the different modes of propagation in Waveguides.	Analyse

iv) **SYLLABUS**

Introduction to Electromagnetic Theory, Review of vector calculus, Expression of curl divergence and Laplacian in cartesian, cylindrical and spherical coordinate system. Electric field and magnetic field, Review of Coulomb's law, Gauss law and Amperes current law. Poisson and Laplace equations, Determination of E and V using Laplace equation.

Derivation of capacitance and inductance of two wire transmission line and coaxial cable, Energy stored in Electric and Magnetic field. Displacement current density, continuity equation. Magnetic vector potential. Relation between scalar potential and vector potential. Maxwell's equation from fundamental laws. Boundary condition of electric field and magnetic field from Maxwells equations. Solution of wave equation.

Propagation of plane EM wave in perfect dielectric, lossy medium, good conductor, media attenuation, phase velocity, group velocity, skin depth. Reflection and refraction of plane electromagnetic waves at boundaries for normal & oblique incidence (parallel and perpendicular polarization), Snell's law of refraction, Brewster angle.

Power density of EM wave, Poynting vector theorem. Polarization of electromagnetic wave-linear, circular and elliptical polarisation. Uniform lossless transmission line – line parameters. Transmission line equations, Voltage and Current distribution of a line terminated with load. Reflection coefficient and VSWR. Derivation of input impedance of transmission line.

Transmission line as circuit elements (L and C). Development of Smith chart - calculation of line impedance and VSWR using smith chart. The hollow rectangular wave guide –modes of propagation of wave-dominant mode, group velocity and phase velocity -derivation and simple problems only

**v) a) TEXT BOOKS**

- 1) John D. Kraus, *Electromagnetics*, 5/e, TMH, 2010.
- 2) Mathew N O Sadiku, *Elements of Electromagnetics*, Oxford University Press, 6/e, 2014.
- 3) William, H. Hayt, and John A. Buck, *Engineering Electromagnetics*, McGraw-Hill, 8/e McGraw-Hill, 2014.

b) REFERENCES

- 1) Edminister, *Schaum's Outline of Electromagnetics*, 4/e, McGraw-Hill, 2014.
- 2) Jordan and Balmain, *Electromagnetic waves and Radiating Systems*, PHI, 2/e, 2013
- 3) Martin A Plonus, *Applied Electromagnetics*, McGraw Hill, 2/e, 1978.
- 4) Nannapaneni Narayana Rao, *Elements of Engineering Electromagnetics*, Pearson, 6/e, 2006.
- 5) Umran S. Inan and Aziz S. Inan, *Engineering Electromagnetics*, Pearson, 2010.

vi) COURSE PLAN

Module	Contents	No. of hours
I	Introduction to Electromagnetic Theory. Review of vector calculus- curl, divergence gradient. Rectangular, cylindrical and spherical coordinate systems. Expression of curl divergence and Laplacian in cartesian, cylindrical and spherical coordinate system. Electric field and magnetic field. Review of Coulomb's law, Gauss law and Amperes current law. Poisson and Laplace equations, Determination of E and V using Laplace equation.	13
II	Derivation of capacitance and inductance of two wire transmission line and coaxial cable. Energy stored in Electric and Magnetic field. Displacement current density, continuity equation. Magnetic vector potential. Relation between scalar potential and vector potential. Maxwell's equation from fundamental laws. Boundary condition of electric field and magnetic field from Maxwell's equations. Solution of wave equation	11
III	Propagation of plane EM wave in perfect dielectric, lossy medium, good conductor, media-attenuation, phase velocity, group velocity, skin depth. Reflection and refraction of plane electromagnetic waves at boundaries for normal & oblique incidence (parallel and perpendicular polarization), Snell's law of refraction, Brewster angle.	12
IV	Power density of EM wave, Poynting vector theorem. Polarization of electromagnetic wave-linear, circular and elliptical polarisation. Uniform lossless transmission line - line parameters. Transmission line equations Voltage and Current distribution of a line terminated with load. Reflection coefficient and VSWR. Derivation of input impedance of transmission line	11
V	Transmission line as circuit elements (L and C). Development of Smith chart - calculation of line impedance and VSWR using smith chart. The hollow rectangular wave guide –modes of propagation of wave dominant mode, group velocity and phase velocity -derivation and simple problems only	13
Total hours		60

**vii) ASSESSMENT PATTERN****Mark distribution**

Total Marks	Continuous Internal Evaluation Marks	End Semester Evaluation Marks	End Semester Examination Duration
150	50	100	3 Hours

Continuous Internal Evaluation Pattern:

Attendance	10 Marks
Continuous Assessment Tests (2 numbers)	25 Marks
Assignment/Quiz/Course project	15 Marks

End Semester Examination Pattern:

There will be two parts; Part A and Part B. Part A contain 10 questions with 2 questions from each module, having 3 marks for each question. Students should answer all questions. Part B contains 2 questions from each module of which student should answer any one. Each question can have maximum 2 sub-divisions and carry 14 marks.



Course Code	Course Name	Category	L	T	P	Credit	Year of Introduction
EC1U30F	VLSI CIRCUIT DESIGN	PCC	3	1	0	4	2020

i) **PREREQUISITE:** EC1U20A - Solid State Devices, EC1U20D - Analog Circuits, EC1U20B - Logic Circuit Design

ii) **COURSE OVERVIEW**

This course aims to impart the knowledge of VLSI design methodologies and Digital VLSI circuit design.

iii) **COURSE OUTCOMES**

After the completion of the course, the student will be able to

Course Outcomes	Description	Level
CO 1	Explain the various methodologies in ASIC and FPGA design.	Understand
CO 2	Design various static and dynamic logic circuits using CMOS design	Apply
CO 3	Realize different types of memory elements	Understand
CO 4	Describe the function of various arithmetic units like adders and multipliers	Understand
CO 5	Explain MOSFET fabrication techniques and layout design rules.	Understand

iv) **SYLLABUS**

Introduction: Moore's law. ASIC design, Full custom ASICs, Standard cell based ASICs, Gatearray based ASICs, SoCs, FPGA devices, ASIC and FPGA Design flows, Top-Down and Bottom-Up design methodologies. Logical and Physical design. Speed power and area considerations in VLSI design.

MOSFET Logic Design - NMOS Inverter (Static analysis only), basic logic gates, CMOS logic, Static and transient analysis of CMOS inverter, Switching power dissipation and delays. Realization of logic functions with static CMOS logic, Pass transistor logic, and transmission gate logic.

Dynamic Logic Design-Pre charge- Evaluate logic, Domino Logic, NP domino logic.

Read Only Memory-4x4 MOS ROM Cell Arrays (OR,NOR,NAND)

Random Access Memory –SRAM-Six transistor CMOS SRAM cell, DRAM –Three transistor and One transistor Dynamic Memory Cell.

Adders: Static adder, Carry-Bypass adder, Linear Carry- Select adder, Square- root carry- select adder. Multipliers: Array multiplier.

Material Preparation-Purification and Crystal growth (CZ process), wafer preparation Thermal Oxidation- Growth mechanisms, Dry and Wet oxidation. Diffusion and ion implantation techniques.Epitaxy : molecular beam epitaxy. Lithography - Photo lithographic sequence, Electron Beam Lithography, Etching and metal deposition techniques. MOSFET Fabrication techniques - Twin-Tub fabrication sequence, Fabrication process flow.

Layout Design and Design rules, Stick Diagram and Design rules-micron rules and Lambda rules. (definitions only).layout of CMOS Inverter, two input NAND and NOR gates.

**v) a) TEXT BOOKS**

1. S.M. SZE, *VLSI Technology*, 2/e, Indian Edition, McGraw-Hill,2003
2. Jan M. Rabaey, *Digital Integrated Circuits- A Design Perspective*, Second Edition , Prentice Hall,2005
3. Michael John Sebastian Smith, *Application Specific Integrated Circuits*, 1/e, Pearson Education,2001

c) REFERENCES

1. Sung –Mo Kang & Yusuf Leblebici, *CMOS Digital Integrated Circuits- Analysis & Design*, Third Ed., McGraw-Hill, 2003
2. Neil H.E. Weste, Kamran Eshraghian, *Principles of CMOS VLSI Design- A Systems Perspective*, Second Edition.Pearson Publication, 2005.
3. Wayne Wolf, *Modern VLSI design*, Third Edition, Pearson Education,2002.
4. Razavi, *Design of Analog CMOS Integrated Circuits*, 2/e, McGraw Hill Education India Education, New Delhi, 2003.
5. M.S.Tyagi, *Introduction to Semiconductor Materials*, 1/e, Wiley India, 2008

vi) COURSE PLAN

Module	Contents	No. of hours
I	VLSI Design Methodologies Introduction: Moore’s law, ASIC design, Full custom ASICs, Standard cell based ASICs, Gate array based ASICs, SoCs, FPGA devices, ASIC and FPGA Design flows, Top-Down and Bottom-Up design methodologies. Logical and Physical design. Speed power and area considerations in VLSI design.	13
II	Static CMOS Logic Design MOSFET Logic Design - NMOS Inverter (Static analysis only), basic logic gates, CMOS logic, Static and transient analysis of CMOS inverter, Switching power dissipation and delays. Realization of logic functions with static CMOS logic, Pass transistor logic, and transmission gate logic	13
III	Dynamic logic Design and Storage Cells Dynamic Logic Design-Pre charge- Evaluate logic, Domino Logic, NP domino logic. Read Only Memory-4x4 MOS ROM Cell Arrays(OR,NOR,NAND) Random Access Memory –SRAM-Six transistor CMOS SRAM cell, DRAM –Three transistor and One transistor Dynamic Memory Cell.	13
IV	Arithmetic circuits Adders: Static adder, Carry-Bypass adder, Linear Carry- Select adder, Square- root carry- select adder. Multipliers: Array multiplier	8
V	Fabrication techniques and MOSFET physical Design Material Preparation - Purification and Crystal growth (CZ process),	13



	wafer preparation Thermal Oxidation- Growth mechanisms, Dry and Wet oxidation. Diffusion and ion implantation techniques. Epitaxy : molecular beam epitaxy. Lithography- Photo lithographic sequence, Electron Beam Lithography, Etching and metal deposition techniques. MOSFET Fabrication techniques Twin-Tub fabrication sequence, Fabrication process flow. Layout Design and Design rules, Stick Diagram and Design rules- micron rules and Lambda rules. (Definitions only). Layout of CMOS Inverter, two input NAND and NOR gates.	
	Total hours	60

vii) ASSESSMENT PATTERN**Mark distribution**

Total Marks	Continuous Internal Evaluation Marks	End Semester Evaluation Marks	End Semester Examination Duration
150	50	100	3 Hours

Continuous Internal Evaluation Pattern:

Attendance	10 Marks
Continuous Assessment Tests (2 numbers)	25 Marks
Assignment/Quiz/Course project	15 Marks

End Semester Examination Pattern:

There will be two parts; Part A and Part B. Part A contain 10 questions with 2 questions from each module, having 3 marks for each question. Students should answer all questions. Part B contains 2 questions from each module of which student should answer any one. Each question can have maximum 2 sub-divisions and carry 14 marks.



Course Code	Course Name	Category	L	T	P	Credit	Year of Introduction
EC1U30G	INFORMATION THEORY AND CODING	PCC	3	1	0	4	2020

i) **PREREQUISITE:** MA0U10A - Linear Algebra and Calculus, MA0U20C - Probability, Random Process and Numerical Methods, EC1U20E - Signals and Systems

ii) COURSE OVERVIEW

This course aims to lay down the foundation of information theory introducing both source coding and channel coding. It also aims to expose students to algebraic and probabilistic error-control codes that are used for reliable transmission

iii) COURSE OUTCOMES

After the completion of the course, the student will be able to

Course Outcomes	Description	Level
CO 1	Compute information, entropy and mutual information related with different components in a communication system	Apply
CO 2	Apply Shannon's source coding theorem for data compression	Apply
CO 3	Apply the concept of channel capacity to characterize the limits of error-free transmission.	Apply
CO 4	Design linear block encoders and decoders for error detection and correction.	Apply
CO 5	Apply algebraic codes with reduced structural complexity for error correction.	Apply
CO 6	Perform error detection and correction using convolutional and LDPC codes.	Apply

iv) SYLLABUS

Information, Entropy, Mutual Information – formulation & properties. Discrete Memory-less source, Average codelength, Construction of Instantaneous codes – Kraft's inequality. Discrete Memoryless channels – capacity, channel coding theorem, Gaussian channels, differential entropy. Groups, rings and fields. Block codes – Error detection and correction capability, Generator and parity matrix. Cyclic codes - Polynomial and matrix description, Systematic encoding and decoding, Hamming Codes, BCH codes, Reed-Solomon Codes. Convolutional - State diagram. Trellis diagram. Maximum likelihood decoding. Viterbi algorithm, LDPC Codes.

v) REFERENCE BOOKS

- 1) Joy A Thomas and Thomas M Cover, *Elements of Information Theory*, 2nd edition, Wiley-Interscience, 2005.
- 2) David JC McKay, *Information Theory, Inference and Learning Algorithms*, Cambridge University Press, 2005
- 3) R. G Gallager, *Principles of digital communication*, Cambridge University Press, 2008
- 4) Simon Haykin, *Digital Communication Systems*, 4th edition, Wiley, 2000.
- 5) Ron M Roth, *Introduction to Coding Theory*, Cambridge University Press, 2006
- 6) Shu Lin & Daniel J. Costello. Jr., *Error Control Coding : Fundamentals and Applications*,



2nd Edition, 2001.

7. RüdigerUrbanke and TJ Richardson, *Modern Coding Theory*, Cambridge University, 2008

vi) COURSE PLAN

Module	Contents	No. of hours
I	<p>Entropy, Properties of Entropy, Joint and Conditional Entropy, Mutual Information, Properties of Mutual Information.</p> <p>Discrete memoryless sources, Source code, Average length of source code, Bounds on average length, Uniquely decodable and prefix-free source codes.</p> <p>Kraft Inequality (with proof), Huffman code. Shannon’s source coding theorem (both achievability and converse) and operational meaning of entropy.</p>	13
II	<p>Discrete memoryless channels. Capacity of discrete memoryless channels. Binary symmetric channels (BSC), Binary Erasure channels (BEC). Capacity of BSC and BEC. Channel code. Rate of channel code. Shannon’s channel coding theorem (both achievability and converse without proof) and operational meaning of channel capacity.</p> <p>Modeling of Additive White Gaussian channels. Continuous-input channels with average power constraint. Differential entropy. Differential Entropy of Gaussian random variable. Relation between differential entropy and entropy. Shannon-Hartley theorem (with proof – mathematical subtleties regarding power constraint may be overlooked).</p> <p>Inferences from Shannon Hartley theorem – spectral efficiency versus SNR per bit, power-limited and bandwidth-limited regions, Shannon limit, Ultimate Shannon limit..</p>	13
III	<p>Overview of Groups, Rings, Finite Fields, Construction of Finite Fields from Polynomial rings, Vector spaces.</p> <p>Block codes and parameters. Error detecting and correcting capability. Linear block codes. Two simple examples -- Repetition code and single parity-check code. Generator and parity-check matrix. Systematic form.</p> <p>Maximum likelihood decoding of linear block codes. Bounded distance decoding. Syndrome. Standard array decoding.</p>	13
IV	<p>Cyclic codes. Polynomial and matrix description. Interrelation between polynomial and matrix view point. Systematic encoding. Decoding of cyclic codes. (Only description, no decoding algorithms) Hamming Codes, BCH codes, Reed-Solomon Codes.</p>	11
V	<p>Convolutional Codes. State diagram. Trellis diagram. Maximum likelihood decoding. Viterbi algorithm.</p> <p>Low-density parity check (LDPC) codes. Tanner graph representation. Message-passing decoding for transmission over binary erasure channel.</p>	10
	Total hours	60



Simulation assignments may be conducted on different coding schemes

vii) ASSESSMENT PATTERN

Mark distribution

Total Marks	Continuous Internal Evaluation Marks	End Semester Evaluation Marks	End Semester Examination Duration
150	50	100	3 Hours

Continuous Internal Evaluation Pattern:

Attendance	10 Marks
Continuous Assessment Tests (2 numbers)	25 Marks
Assignment/Quiz/Course project	15 Marks

End Semester Examination Pattern:

There will be two parts; Part A and Part B. Part A contain 10 questions with 2 questions from each module, having 3 marks for each question. Students should answer all questions. Part B contains 2 questions from each module of which student should answer any one. Each question can have maximum 2 sub-divisions and carry 14 marks.



Course Code	Course Name	Category	L	T	P	Credit	Year of Introduction
EC1U30H	COMPREHENSIVE COURSE WORK	PCC	1	0	0	1	2020

i) **PREREQUISITE:** EC1U20D - Analog Circuits, EC1U20B - Logic Circuit Design, EC1U30A - Linear Integrated Circuits, EC1U30B - Digital Signal processing, EC1U30C - Analog and Digital Communication

ii) **COURSE OVERVIEW**

The objective of this Course work is to ensure the comprehensive knowledge of each student in the most fundamental Program core courses in the curriculum. Five core courses credited from Semesters 3, 4 and 5 are chosen for the detailed study in this course work. This course has an End Semester Objective Test conducted by the University for 50 marks. One hour is assigned per week for this course for conducting mock tests of objective nature in all the listed five courses.

iii) **COURSE OUTCOMES**

After the completion of the course, the student will be able to

Course Outcomes	Description	Level
CO 1	Apply the knowledge of circuit theorems and solid state physics to solve the problems in electronic Circuits	Apply
CO 2	Design a logic circuit for a specific application	Apply
CO 3	Design linear IC circuits for linear and non-linear circuit applications.	Apply
CO 4	Explain basic signal processing operations and filter designs	Understand
CO 5	Explain existent analog and digital communication systems	Understand

iv) **SYLLABUS**

Full syllabus of all the five subjects

v) **COURSE PLAN**

No	Topics	No. of hours
1	EC1U20D - Analog Circuits	
1.1	Mock Test on Module 1 and Module 2	2
1.2	Mock Test on Module 3, Module 4 and Module 5	



2	EC1U20B - Logic Circuit Design	
2.1	Mock Test on Module 1 and Module 2	2
2.2	Mock Test on Module 3, Module 4 and Module 5	
3	EC1U30A - Linear Integrated Circuits	
3.1	Mock Test on Module 1 and Module 2	2
3.2	Mock Test on Module 3, Module 4 and Module 5	
4	EC1U30B - Digital Signal processing	
4.1	Mock Test on Module 1 and Module 2	2
4.2	Mock Test on Module 3, Module 4 and Module 5	
5	EC1U30C - Analog and Digital Communication	
5.1	Mock Test on Module 1 and Module 2	2
5.2	Mock Test on Module 3, Module 4 and Module 5	
	Revisions and Remedial	5
	Total hours	15

vi) ASSESSMENT PATTERN**Mark distribution**

Total Marks	Continuous Internal Evaluation Marks	End Semester Evaluation Marks	End Semester Examination Duration
50	0	50	1 hour

End Semester Examination Pattern:

Objective Questions with multiple choice (Four). Question paper include Fifty Questions of One mark each covering the five identified courses



Course Code	Course Name	Category	L	T	P	Credit	Year of Introduction
EC1U38C	COMMUNICATION LAB	PCC	0	0	3	2	2020

i) **PREREQUISITE:** EC1U30C - Analog and Digital Communication, EC1U30B - Digital Signal Processing.

ii) **COURSE OVERVIEW**

Objective of the course is to simulate the system performance parameter of a digital communication system and to emulate a communication system with software-designed-radio.

iii) **COURSE OUTCOMES**

After the completion of the course, the student will be able to

Course Outcomes	Description	Level
CO 1	Implement simple prototype circuits for analog and digital modulation techniques.	Apply
CO 2	Use matlab program to Simulate the error performance of standard binary and M -ary modulation schemes.	Apply
CO 3	Develop hands-on skills to emulate a communication system with software-designed-radio.	Apply

iv) **SYLLABUS**

FM generation and demodulation using PLL, Generation and Detection of PCM/ BPSK/ 16-QPSK/Delta modulated signals.

Performance of Waveform Coding Using PCM, Pulse Shaping and Matched Filtering, Eye Diagram, Error Performance of BPSK, Error Performance of QPSK.

Familiarization with Software Defined Radio, FM Transmission and Reception

v) **REFERENCES**

- 1) Carl Laufer, *The Hobbyist's Guide to the RTL-SDR: Really Cheap Software Defined Radio*, 4/e, Createspace Independent Publishing Platform, 2015.
- 2) Neel Pandeya, *Implementation of a Simple FM Receiver in GNU Radio*, <https://kb.ettus.com/>
- 3) WH Tranter, KS Shanmugan, TS Rappaport, KL Kosbar, *Principles of Communication Systems Simulation with Wireless Applications*, Prentice Hall, 2004.
- 4) Michael Ossmann, *Software Defined Radio with HackRF*, YouTube Tutorial
- 5) Mathuranathan Viswanathan, *Digital Modulations using Python*, 2019.



vi) COURSE PLAN

Experiment No.	List of exercises/experiments	No. of hours
	Part A	
	The students shall design and setup simple prototype circuits with the help of available ICs. They can observe waveforms produced by these circuits for standard ideal inputs.	
I	FM generation and demodulation using PLL	6
II	Generation and Detection of BPSK	
	Part B	
	The experiments in Part B are software simulations and can be done using GNU Octave or Python. Other software such as MATLAB/SCILAB/LabVIEW can also be used.	
	The students shall write scripts to simulate components of communication systems. They shall plot various graphs that help to appreciate and compare performance.	
I	Performance of Waveform Coding Using PCM <ol style="list-style-type: none"> 1. Generate a sinusoidal waveform with a DC offset so that it takes only positive amplitude value. 2. Sample and quantize the signal using a uniform quantizer with number of representation levels L. Vary L. Represent each value using decimal to binary encoder. 3. Compute the signal-to-noise ratio in dB. 4. Plot the SNR versus number of bits per symbol. Observe that the SNR increases linearly. 	3
II	Pulse Shaping and Matched Filtering <ol style="list-style-type: none"> 1. Generate a string of message bits. 2. Use root raised cosine pulse $p(t)$ as the shaping pulse and generate the corresponding baseband signal with a fixed bit duration T_b. You may use roll-off factor as $\alpha = 0.4$. 3. Simulate transmission of baseband signal via an AWGN channel. 4. Apply matched filter with frequency response $P_r(f) = P^*(f)$ to the received signal. 5. Sample the signal at mT_b and compare it against the message sequence. 	3
III	Eye Diagram <ol style="list-style-type: none"> 1. Generate a string of message bits. 2. Use raised cosine pulse $p(t)$ as the shaping pulse and generate the corresponding baseband signal with a fixed bit duration T_b. You may use roll-off factor as $\alpha = 0.4$. 3. Use various roll off factors and plot the eye diagram in each 	3



	case for the received signal. Make a comparison study among them.	
IV	Error Performance of BPSK <ol style="list-style-type: none"> 1. Generate a string of message bits. 2. Encode using BPSK with energy per bit E_b and represent it using points in a signal-space. 3. Simulate transmission of the BPSK modulated signal via an AWGN channel with variance $N_0/2$. 4. Detect using an ML decoder and plot the probability of error as a function of SNR per bit E_b/N_0. 	3
V	Error Performance of QPSK <ol style="list-style-type: none"> 1. Generate a string of message bits. 2. Encode using QPSK with energy per symbol E_s and represent it using points in a signal-space. 3. Simulate transmission of the QPSK modulated signal via an AWGN channel with variance $N_0/2$ in both I-channel and Q-channel. 4. Detect using an ML decoder and plot the probability of error as a function of SNR per bit E_b/N_0 where $E_s = 2E_b$. 	3
	Part C	
	The students shall emulate communication systems with the help of software-defined-radio hardware and necessary control software. Use available blocks in GNU Radio to implement all the signal processing. These experiments will help students to appreciate better how theoretical concepts are translated into practice.	
I	Familiarization with Software Defined Radio (Hardware and Control Software) <ol style="list-style-type: none"> 1. Familiarize with an SDR hardware for reception and transmission of RF signal. 2. Familiarize how it can be interfaced with computers. 3. Familiarize with GNU Radio (or similar software's like Simulink/ Lab-View) that can be used to process the signals received through the SDR hardware. 4. Familiarize available blocks in GNU Radio. Study how signals can be generated and spectrum (or power spectral density) of signals can be analysed. Study how filtering can be performed. 	6
III	FM Reception <ol style="list-style-type: none"> 1. Receive digitized FM signal (for the clearest channel in the lab) using the SDR board. 2. Set up an LPF and FM receiver using GNU Radio. 3. Use appropriate sink in GNU Radio to display the spectrum of signal. 4. Resample the voice to make it suitable for playing on a computer speaker. 	6
	Total hours	33

**vii) ASSESSMENT PATTERN****Mark distribution**

Total Marks	Continuous Internal Evaluation Marks	End Semester Evaluation Marks	End Semester Examination Duration
150	75	75	3 Hours

Continuous Internal Evaluation Pattern:

Attendance	15 Marks
Continuous Assessment	30 Marks
Internal Test (Immediately before the II internal test)	30 Marks

End Semester Examination Pattern:

Preliminary work	15 marks
Implementing the work/Conducting the experiment	20 marks
Performance, result and inference (usage of equipment and troubleshooting):	15 marks
Viva voce	20 marks
Record	5 Marks



Course Code	Course Name	Category	L	T	P	Credit	Year of Introduction
EC1U39A	MINIPROJECT	PWS	0	0	3	2	2020

i) COURSE OVERVIEW:

The objective of this course is to estimate the ability of the students in transforming the theoretical knowledge studied in to a working model of an electronic system. It aims at enabling the students to gain experience in organisation and implementation of small projects. Also, focuses on the design and development of Small electronic project based on hardware or a combination of hardware and software for electronics systems

ii) COURSE OUTCOMES

After the completion of the course, the student will be able to

Course Outcomes	Description	Level
CO 1	Identify the functional aspects and design requirements of the project.	Apply
CO 2	Design the circuit/system to meet the requirements.	Apply
CO 3	Implement the prototype of the circuit/system.	Apply
CO 4	Practice professional ethics.	Apply
CO 5	Work effectively as an individual and as a member of a team in the development of technical projects..	Apply
CO 6	Communicate effectively, the project-related activities and findings.	Apply

iii) COURSE PLAN

Module	Contents	No. of hours
	<p>In this course, each group consisting of three/four members is expected to design and develop a moderately complex electronic system with practical applications, this should be a working model. The basic concept of product design may be taken into consideration.</p> <p>Students should identify a topic of interest in consultation with Faculty/Advisor. Review the literature and gather information pertaining to the chosen topic. State the objectives and develop a methodology to achieve the objectives. Carryout the design/fabrication or develop codes/programs to achieve the objectives. Demonstrate the novelty of the project through the results and outputs.</p> <p>The progress of the mini project is evaluated based on a minimum of two reviews. The review committee may be constituted by the Head of the Department. A project report is required at the end of the semester. The product has to be demonstrated for its full design specifications.</p>	



	Innovative design concepts, reliability considerations, aesthetics/ergonomic aspects taken care of in the project shall be given due weight.	
	Total hours	45

iv) ASSESSMENT PATTERN**Mark distribution**

Total Marks	Continuous Internal Evaluation Marks	End Semester Evaluation Marks	End Semester Examination Duration
150	75	75	3 Hours

Continuous Internal Evaluation Pattern:

Attendance	10 Marks
Marks awarded based on guide's evaluation	15 Marks
Project Report	10 Marks
Evaluation by Committee	40 Marks

End Semester Examination Pattern:

Level of completion	10 marks
Demonstration of functionality	25 marks
Project Report	10 marks
Viva-voce	20 marks
Presentation	10 Marks



PROGRAMME ELECTIVE -I

Course Code	Course Name	Category	L	T	P	Credit	Year of Introduction
EC1U31A	DIGITAL SYSTEM DESIGN	PEC	2	1	0	3	2020

i) **PREREQUISITE:** EC1U20B - Logic Circuit Design

ii) **COURSE OVERVIEW**

This course aims to design hazard free synchronous and asynchronous sequential circuits and implement the same in the appropriate hardware device

iii) **COURSE OUTCOMES**

After the completion of the course, the student will be able to

Course Outcomes	Description	Level
CO 1	Analyze clocked synchronous sequential circuits	Understand
CO 2	Analyze asynchronous sequential circuits	Understand
CO 3	Design hazard free circuits	Apply
CO 4	Diagnose faults in digital circuits	Apply
CO 5	Summarize the architecture of FPGA and CPLDs	Understand

iv) **SYLLABUS**

Analysis of clocked Synchronous Sequential Networks (CSSN), Modelling of CSSN – State assignment and reduction, Design of CSSN, ASM Chart and its realization.

Analysis of Asynchronous Sequential Circuits (ASC), Flow table reduction- Races in ASC, State assignment problem and the transition table- Design of AS, Design of ALU.

Hazards – static and dynamic hazards – essential, Design of Hazard free circuits – Data synchronizers, Mixed operating mode asynchronous circuits, Practical issues- clock skew and jitter, Synchronous and asynchronous inputs – switch bouncing.

Fault table method – path sensitization method – Boolean difference method, Kohavi algorithm, Automatic test pattern generation – Built in Self Test (BIST).

CPLDs and FPGAs - Xilinx XC 9500 CPLD family, functional block diagram– input output block architecture - switch matrix, FPGAs – Xilinx XC 4000 FPGA family – configurable logic block - input output block, Programmable interconnect.

**v) a) TEXT BOOKS**

- 1) Donald G Givone, *Digital Principles & Design*, Tata McGraw Hill, 2017
- 2) John F Wakerly, *Digital Design | With an Introduction to the Verilog HDL, VHDL, and SystemVerilog*, 6th Edition, Pearson Education Delhi, 2018
- 3) John M Yarbrough, *Digital Logic Applications and Design*, Thomson Learning

b) REFERENCES

- 1) MironAbramovici, Melvin A. Breuer and Arthur D. Friedman, *Digital Systems Testing and Testable Design*, John Wiley & Sons Inc.
- 2) Morris Mano, M.D.Ciletti, *Digital Design*, 5th Edition, PHI
- 3) N. N. Biswas, *Logic Design Theory*, PHI
- 4) Richard E. Haskell, Darrin M. Hanna, *Introduction to Digital Design Using Digilent*
- 5) *FPGA Boards*, LBE Books- LLC
- 6) Samuel C. Lee, *Digital Circuits and Logic Design*, PHI
- 7) Z. Kohavi, *Switching and Finite Automata Theory*, 2nd ed., TMH, 2001

vi) COURSE PLAN

Module	Contents	No. of hours
I	Clocked Synchronous Networks: Analysis of clocked Synchronous Sequential Networks (CSSN), Modelling of CSSN – State assignment and reduction, Design of CSSN, ASM Chart and its realization.	9
II	Asynchronous Sequential Circuits: Analysis of Asynchronous Sequential Circuits (ASC), Flow table reduction- Races in ASC, State assignment problem and the transition table- Design of AS, Design of ALU.	10
III	Hazards: Hazards – static and dynamic hazards – essential, Design of Hazard free circuits – Data synchronizers, Mixed operating mode asynchronous circuits, Practical issues- clock skew and jitter, Synchronous and asynchronous inputs – switch bouncing	9
IV	Faults: Fault table method – path sensitization method – Boolean difference method, Kohavi algorithm, Automatic test pattern generation – Built in Self Test (BIST)	9
V	CPLDs and FPGA: CPLDs and FPGAs - Xilinx XC 9500 CPLD family, functional block diagram– input output block architecture - switch matrix, FPGAs – Xilinx XC 4000 FPGA family – configurable logic block - input output block, Programmable interconnect	8
	Total hours	45

**vii) ASSESSMENT PATTERN****Mark distribution**

Total Marks	Continuous Internal Evaluation Marks	End Semester Evaluation Marks	End Semester Examination Duration
150	50	100	3 Hours

Continuous Internal Evaluation Pattern:

Attendance	10 Marks
Continuous Assessment Tests (2 numbers)	25 Marks
Assignment/Quiz/Course project	15 Marks

End Semester Examination Pattern:

There will be two parts; Part A and Part B. Part A contain 10 questions with 2 questions from each module, having 3 marks for each question. Students should answer all questions. Part B contains 2 questions from each module of which student should answer any one. Each question can have maximum 2 sub-divisions and carry 14 marks.



Course Code	Course Name	Category	L	T	P	Credit	Year of Introduction
EC1U31B	POWER ELECTRONICS	PEC	3	0	0	3	2020

i) **PREREQUISITE:** EC1U20A - Solid State Devices, EC1U20D - Analog Circuits

ii) COURSE OVERVIEW

Goal of this course is to provide an insight into the basic concepts of various power electronic circuits and their applications.

iii) COURSE OUTCOMES

After the completion of the course, the student will be able to

Course Outcomes	Description	Level
CO 1	Describe the characteristics of important power semiconductor switches	Understand
CO 2	Apply the principle of drive circuits and snubber circuits for power semiconductor switches	Apply
CO 3	Explain the concept of diode bridge rectifiers and Controlled rectifiers	Understand
CO 4	Explain DC – DC Switch-Mode Converters	Understand
CO 5	Illustrate the principle of DC – AC Switch-Mode Inverter	Apply
CO 6	Explain the principle of power electronics for various applications	Understand

iv) SYLLABUS

Power diodes, Power BJT, Power MOSFET and IGBT - static and dynamic characteristics, SCR and GTO

BJT and MOSFET drive circuits, Snubber circuits, Three phase diode bridge rectifiers, Single phase and three phase controlled rectifiers.

Buck, Boost and Buck-boost DC-DC converters

Waveforms and expression of DC-DC converters for output voltage, voltage and current ripple under continuous conduction mode. (No derivation required)

Isolated converters: Flyback, Forward, Push Pull, Half bridge and Full bridge converters – Waveforms and governing equations (No derivation required)

Inverter topologies, Driven Inverters: Push-Pull, Half bridge and Full bridge configurations, Three phase inverter, Pulse width modulation

DC Motor Drives, Induction Motor Drives, Residential and Industrial applications.

v) a) TEXT BOOKS

- 1) Umanand L, *Power Electronics: Essentials & Applications*, Wiley India, 2015
- 2) Ned Mohan, Tore M Undeland, William P Robbins., *Power Electronics: Converters, Applications, and Design*, 3/e, Wiley India Pvt. Ltd, 2015

**b) REFERENCES**

- 1) Muhammad H. Rashid., *Power Electronics: Circuits, Devices, and Applications*, 4/e, Pearson Education India, 2014.
- 2) Daniel W. Hart, *Power Electronics*, McGraw Hill, 2011.

vi) COURSE PLAN

Module	Contents	No. of hours
I	Power diodes and Bipolar power transistors – structure, static and dynamic characteristics Power MOSFET and IGBT – structure, static and dynamic characteristics SCR and GTO – construction and characteristics	9
II	BJT and MOSFET driver circuits (*at least two circuits each) *Snubber circuits – ON and OFF snubbers Three phase diode bridge rectifiers – basic principles only *Single phase and three phase Controlled rectifiers (with R, RL & RLE loads) – basic principles only. (*Simulate the basic circuits)	9
III	Buck, Boost and Buck-Boost DC-DC converters Waveforms and expression of DC-DC converters for output voltage, voltage and current ripple under continuous conduction mode (No derivation required) Isolated converters: Flyback, Forward, Push Pull, Half bridge and Full bridge converters – Waveforms and governing equations (No derivation required) DC-AC Switch Mode Inverters	10
IV	Inverter topologies Driven Inverters: Push-Pull, Half bridge and Full bridge configurations Three phase inverter Sinusoidal and Space vector modulation PWM in three phase inverters	9
V	DC Motor Drives – Adjustable-speed DC drive Induction Motor Drives – Variable frequency PWM-VSI drives Residential and Industrial applications	8
	Total hours	45

**vii) ASSESSMENT PATTERN****Mark distribution**

Total Marks	Continuous Internal Evaluation Marks	End Semester Evaluation Marks	End Semester Examination Duration
150	50	100	3 Hours

Continuous Internal Evaluation Pattern:

Attendance	10 Marks
Continuous Assessment Tests (2 numbers)	25 Marks
Assignment/Quiz/Course project	15 Marks

End Semester Examination Pattern:

There will be two parts; Part A and Part B. Part A contain 10 questions with 2 questions from each module, having 3 marks for each question. Students should answer all questions. Part B contains 2 questions from each module of which student should answer any one. Each question can have maximum 2 sub-divisions and carry 14 marks.



Course Code	Course Name	Category	L	T	P	Credit	Year of Introduction
EC1U31C	DATA ANALYSIS	PEC	2	1	0	3	2020

i) COURSE OVERVIEW

Goal of this course is to set the foundation for students to develop new-age skills pertaining to analysis of large-scale data using modern tools.

ii) COURSE OUTCOMES

After the completion of the course, the student will be able to:

Course Outcomes	Description	Level
CO 1	Interpret the data by reading the data from spreadsheets and databases.	Understand
CO 2	Use pandas library to process data frames.	Apply
CO 3	Compute the principal components and perform cluster analysis on data frames.	Apply
CO 4	Apply Bayesian analysis on data frames.	Apply
CO 5	Apply machine learning in data analysis problems.	Apply
CO 6	Explain methods in high performance computing for data analysis.	Understand

iii) SYLLABUS

Numpy and Scipy Python modules, reading and processing spreadsheets and csv files with Python, data visualization with Matplotlib, three dimensional visualization using Mayavi module, reading data from sql and mongodb databases with Python, Reading and writing pandas dataframes, Reading and writing .txt, .csv, .pdf, .html and json files with pandas, Use of pivot tables. Pickling of data frames in Python, Dimensionality reduction with PCA, Hierarchical and K-means clustering, Bayesian analysis, Use of pymc3 module to compute the posterior probability. MAP Estimation, Kernel density estimation, Supervised and unsupervised learning, scikit-learn, Deep learning with convolutional neural networks, Use of Keras and Tensorflow. Machine learning with pytorch, Reading and writing images with openCV. Case study of character recognition with MNIST dataset. High performance computing for machine learning.

iv) a) TEXT BOOKS

- 1) Fabio Nelli, *Python Data Analytics: With Pandas, NumPy, and Matplotlib*, 2/e, Apress, 2018
- 2) Wes McKinney, *Python for Data Analysis: Data Wrangling with Pandas, NumPy, and IPython*, 2/e, O'Reilly, 2017

b) REFERENCES

- 1) Cyrille Rossant, *IPython Interactive Computing and Visualization Cookbook*, 2/e, PACKT Open Source Publishing, 2018
- 2) Francois Chollet, *Deep Learning with Python*, 1/e, Manning, 2017
- 3) Peters Morgan, *Data Analysis from Scratch with Python*, AI Sciences, 2018



v) COURSE PLAN

Module	Contents	No. of hours
I	Overview of Data Analysis and Python: Numpy and Scipy Python modules for data analysis. Reading and processing spreadsheets and csv files with Python using xlr, xlwt and openpyxl. Data visualization with Matplotlib. Two dimensional charts and plots. Scatter plots with matplotlib. Three dimensional visualization using Mayavi module. Reading data from sql and mongodb databases with Python.	9
II	Big Data Arrays with Pandas: Familiarization of the python pandas. Reading and writing pandasdataframes. Reading rows and columns from pandasdataframe. Handling NaN values. Reading and writing .txt, .csv, .pdf, .html and json files with pandas. Merging, concatenating and grouping of data frames. Use of pivot tables. Pickling of data frames in Python.	8
III	PCA and Cluster Analysis: Singular value decomposition of a matrix/array. Eigen values and eigen vectors. Principal component analysis of a data frame. Scree plot. Dimensionality reduction with PCA. Loadings for principal components. Case study with Python. Cluster analysis. Hierarchical and K-means clustering. Interpretation of dendrograms.	8
IV	Statistical Data Analysis: Hypothesis testing. Bayesian analysis. Meaning of prior, posterior and likelihood functions. Use of pymc3 module to compute the posterior probability. MAP Estimation. Credible interval, conjugate distributions. Contingency table and chi square test. Kernel density estimation.	10
V	Machine Learning: Supervised and unsupervised learning. Use of scikit-learn. Regression using scikit-learn. Deep learning with convolutional neural networks. Structure of CNN. Use of Keras and Tensorflow. Machine learning with pytorch. Reading and writing images with openCV. Case study of character recognition with MNIST dataset. High performance computing for machine learning. Use of numba, jit and numexpr for faster Python code. Use of Ipython-parallel.	10
	Total hours	45

Simulation Assignments

1. Download the iris data set and read into a pandas data frame. Extract the header and replace with a new header. Extract columns and rows. Extract pivot tables. Filter the data based on the labels. Store a pivot table as a pickle and retrieve it.

2. For the same data set, perform principal component analysis. Observe the scree plot. Identify the principal components. Obtain a low dimensional data, with only the principal components and compute the mean square error between the original data and the approximated one. Compute the loadings for the principal components.



3. For the same data, perform hierarchical and K-means clustering with Python codes. Obtain dendrograms in each case and appreciate the clusters.
4. Download the MNIST letter data set. Construct a CNN network with appropriate layers using Keras and Tensorflow. Train the CNN with the MNIST data set. Appreciate the selection and use of training, test and cross-validation data sets. Save the model and weights and use the model to identify letter images. You may use openCV for reading images.
5. Write a Python script to generate alphanumeric images (26 upper case, 26 lowercase and 10 numbers each 12 point in size) of say 16x16 dimension out of windows .ttf files. Create 62 folders each containing a data set of every alphanumeric character. Create a new CNN with Keras and Tensorflow. Create a cross validation data set by taking 10 images out of every 62 folder. Use 80% of the total data for training and 20% for testing the CNN. Use an HPCC like system to train the model and save the model and weight. Test this model to recognize letter images. You may use openCV for reading images.
6. Repeat assignment 4 using pytorch instead of Keras.
7. Repeat assignment 5 using pytorch instead of Keras.

vi) ASSESSMENT PATTERN

Mark distribution

Total Marks	Continuous Internal Evaluation Marks	End Semester Evaluation Marks	End Semester Examination Duration
150	50	100	3 Hours

Continuous Internal Evaluation Pattern:

Attendance	10 Marks
Continuous Assessment Tests (2 numbers)	25 Marks
Assignment/Quiz/Course project	15 Marks

End Semester Examination Pattern:

There will be two parts; Part A and Part B. Part A contain 10 questions with 2 questions from each module, having 3 marks for each question. Students should answer all questions. Part B contains 2 questions from each module of which student should answer any one. Each question can have maximum 2 sub-divisions and carry 14 marks.



Course Code	Course Name	Category	L	T	P	Credit	Year of Introduction
EC1U31D	EMBEDDED SYSTEM	PEC	3	0	0	3	2020

i) **PREREQUISITE:**EC1U20B - Logic Circuit Design, EC1U20D - Analog Circuits, EC1U20F - Computer Architecture and Microcontrollers

ii) **COURSE OVERVIEW**

This course is designed to introduce embedded systems, various protocols used for communication between peripheral devices and processors, the ARM processor organization and programming, and the basic concepts of real time operating systems.

iii) **COURSE OUTCOMES**

After the completion of the course, the student will be able to

Course Outcomes	Description	Level
CO 1	Discuss the basic concepts of embedded systems and different phases in the embedded system design process/EDLC.	Understand
CO 2	Describe the different ways of communicating with I/O devices and standard I/O interfaces.	Understand
CO 3	Explain the ARM processor organization and to write programs in assembly and high-level languages for ARM processors.	Understand
CO 4	Explain the basics of real time operating systems and their use in embedded systems.	Understand
CO 5	Apply the knowledge for solving real-life problems with the help of an embedded system.	Apply

iv) **SYLLABUS**

Introduction to Embedded Systems- Complex Systems and Microprocessors- The Embedded System Design Process - Formalisms for System Design- Embedded product development cycle (EDLC).

Embedded system interfacing and peripherals- Serial Communication Standards and Devices- Serial Bus Protocols - Parallel communication standards- Memory- DMA- I/O Device- Interrupts.

ARM Processor fundamentals- ARM Processor architecture- ARM Assembly Language Programming- ARM Organization and Implementation, ARM Programming, The Thumb Instruction Set, The ARM memory interface, The Advanced Microcontroller Bus Architecture (AMBA).

Real Time Operating Systems - Kernel, types of operating systems, Tasks, process, threads, multiprocessing and multi-tasking, task scheduling, types, threads and process scheduling, task communication, task synchronization, device drivers, choosing an RTOS.

v) a) **TEXT BOOKS**

1) K.V. Shibu, *Introduction to Embedded Systems*, 2/e, McGraw Hill Education India, 2016.



- 2) Wayne Wolf, *Computers as Components: Principles of Embedded Computing System Design*, Morgan Kaufman Publishers - Elsevier 3ed, 2008.
- 3) Steve Furber, *ARM system-on-chip architecture*, Addison Wesley, Second Edition, 2000.
- 4) Raj Kamal, *Embedded Systems Architecture*, Programming and Design, TMH, 2003.

b) REFERENCES

- 1) David E. Simon, *An Embedded Software Primer*, Pearson Education Asia, First Indian Reprint 2000.
- 2) Steve Heath, *Embedded Systems Design*, Newnes – Elsevier 2ed, 2002.
- 3) Andrew N. Sloss, Dominic Symes, Chris Wright, *ARM System Developer's Guide Designing Optimizing System Software*, Morgan Kaufmann Publishers 2004
- 4) Frank Vahid and Tony Givargis, *Embedded Systems Design – A Unified Hardware / Software Introduction*, John Wiley, 2002.
- 5) Tammy Noergaard, *Embedded Systems Architecture, A Comprehensive Guide for Engineers and Programmers*, Newnes – Elsevier 2ed, 2013.
- 6) Iyer - *Embedded Real time Systems*, 1/e, McGraw Hill Education New Delhi, 2003
- 7) Lyla B. Das, *Embedded Systems: An Integrated Approach*, 1/e, 2012.
- 8) Sarmad Naimi, Muhammad Ali Mazidi, Sepehr Naimi, *The STM32F103 Arm Microcontroller and Embedded Systems: Using Assembly and C*, MicroDigital Ed., 2020
- 9) Shujen Chen, Muhammad Ali Mazidi, Eshragh Ghaemi, *STM32 Arm Programming for Embedded Systems*, 2018.

vi) COURSE PLAN

Module	Contents	No. of hours
I	<p>Introduction to Embedded Systems</p> <p>Complex Systems and Microprocessors- Embedding Computers, Characteristics of Embedded Computing Applications, Application of Microprocessors, Challenges in Embedded Computing System, Characteristics and quality attributes of an embedded system, Performance in Embedded Computing.</p> <p>The Embedded System Design Process -Requirements, Specification, Architecture Design, Designing Hardware and Software Components, System Integration, An embedded system design example.</p> <p>Formalisms for System Design- Structural Description, Behavioral Description.</p> <p>Embedded product development cycle (EDLC) -Different phases of EDLC, EDLC models</p>	6
II	<p>Embedded system interfacing and peripherals</p> <p>Communication devices: Serial Communication Standards and Devices - UART, HDLC and SPI.</p>	9



	<p>Serial Bus Protocols -I2C Bus, CAN Bus and USB Bus. Parallel communication standards -ISA, PCI and PCI-X Bus.</p> <p>Memory: Memory devices and systems – ROM-Flash, EEPROM, RAM-SRAM, DRAM, memory mapping and addresses, memory management unit–DMA, I/O Device, Interrupts-Interrupt sources, recognizing an interrupt, ISR – Device drivers for handling ISR, Interrupt latency.</p>	
III	<p>ARM Processor fundamentals</p> <p>ARM Processor architecture The Acorn RISC Machine, Architectural inheritance, The ARM programmer's model, ARM development tools.</p> <p>ARM Assembly Language Programming Data processing instructions, Data transfer instructions, Control flow instructions, writing simple assembly language programs.</p> <p>ARM Organization and Implementation Three stage pipeline ARM organization, Five stage pipeline ARM organization, ARM instruction execution, ARM implementation, The ARM coprocessor interface.</p>	8
IV	<p>ARM Programming</p> <p>Architectural Support for High-Level Languages Abstraction in software design, Data types, Floating-point data types, The ARM floating-point architecture, Expressions, Conditional statements, Loops, Functions and procedures, Use of memory, Run-time environment.</p> <p>The Thumb Instruction Set The Thumb bit in the CPSR, The Thumb programmer's model, Thumb branch instructions, Thumb software interrupt instruction, Thumb data processing instructions, Thumb single register data transfer instructions, Thumb multiple register data transfer instructions, Thumb breakpoint instruction, Thumb implementation, Thumb applications.</p> <p>Architectural Support for System Development The ARM memory interface, The Advanced Microcontroller Bus Architecture (AMBA).</p> <p>Programming Assembly and C language programming applications of embedded systems.</p>	10
V	<p>Real Time Operating Systems</p> <p>Operating system basics Kernel, types of operating systems.</p> <p>Real time operating systems Tasks, process, threads, multiprocessing and multi-tasking, task scheduling, types, threads and process scheduling, task communication, task synchronization, device drivers, choosing an RTOS.</p>	12
	Total hours	45



Simulation Assignments

1. At least one assignment should be of programming (Both assembly and C languages) of embedded processor with simulation tools like Keil, Eclipse.

Programming assignments can be the following

- (a) Print “HELLO WORLD” or any text
- (b) Data transfer, copy operations
- (c) Arithmetic operations
- (d) Sorting operations
- (e) input/output control
- (f) programs using functions
- (g) Interrupts and ISR
- (h) controller design

2. Another assignment should be an embedded system design mini project.

Mini project can be done in the following areas.

- (a) Elevator controller design
- (b) Chocolate vending machine design
- (c) Industrial controller using sensors
- (d) IOT applications using sensors, communication devices and actuators

vii) ASSESSMENT PATTERN

Mark distribution

Total Marks	Continuous Internal Evaluation Marks	End Semester Evaluation Marks	End Semester Examination Duration
150	50	100	3 Hours

Continuous Internal Evaluation Pattern:

Attendance	10 Marks
Continuous Assessment Tests (2 numbers)	25 Marks
Assignment/Quiz/Course project	15 Marks

End Semester Examination Pattern:

There will be two parts; Part A and Part B. Part A contain 10 questions with 2 questions from each module, having 3 marks for each question. Students should answer all questions. Part B contains 2 questions from each module of which student should answer any one. Each question can have maximum 2 sub-divisions and carry 14 marks.



Course Code	Course Name	Category	L	T	P	Credit	Year of Introduction
EC1U31E	DIGITAL IMAGE PROCESSING	PEC	2	1	0	3	2020

i) **PREREQUISITE:** EC1U30B – Introduction to Digital Signal Processing

ii) **COURSE OVERVIEW**

This course aims to develop the skills for methods of various transformation and analysis of image enhancement, image reconstruction, image compression, image segmentation and image representation.

iii) **COURSE OUTCOMES**

After the completion of the course, the student will be able to

Course Outcomes	Description	Level
CO 1	Explain the various basic concepts of digital image processing	Understand
CO 2	Apply the concepts to analyse a 2D discrete signal in time and frequency domain	Apply
CO 3	Explain two-dimensional sampling and quantization	Understand
CO 4	Apply the concepts to enhance and restore digital images using various filtering techniques	Apply
CO 5	Explain various image compression techniques	Understand

iv) **SYLLABUS**

Digital Image Fundamentals: Image representation, basic relationship between pixels, elements of DIP system, elements of visual perception-simple image formation model. Vidicon and Digital Camera working principles Brightness, contrast, hue, saturation, mach band effect Colour image fundamentals-RGB, CMY, HIS models, 2D sampling, quantization

Review of matrix theory: row and column ordering- Toeplitz, Circulant and block matrix 2D Image transforms: DFT, its properties, Walsh transform, Hadamard transform, Haar transform, DCT, KL transform and Singular Value Decomposition. Image Compression: Need for compression, Basics of lossless compression – bit plane coding, run length encoding and predictive coding, Basics of lossy compression – uniform and non-uniform quantization techniques used in image compression, Concept of transform coding, JPEG Image compression standard

Image Enhancement: Spatial domain methods: point processing- intensity transformations, histogram processing, image subtraction, image averaging. Spatial filtering- smoothing filters, sharpening filters. Frequency domain methods: low pass filtering, high pass filtering, homomorphic filter

Image Restoration: Degradation model, Unconstraint restoration- Lagrange multiplier and constraint restoration Inverse filtering- removal of blur caused by uniform linear motion, Weiner filtering, Geometric transformations-spatial transformations



Image segmentation: Classification of Image segmentation techniques, region approach, clustering techniques. Segmentation based on thresholding, edge based segmentation. Classification of edges, edge detection, Hough transform, active contour.

v) a) TEXT BOOKS

- 1) Gonzalez Rafel C, *Digital Image Processing*, Pearson Education, 2009
- 2) S Jayaraman, S Esakkirajan, T Veerakumar, *Digital image processing*, Tata McGraw Hill, 2015

b) REFERENCES

- 1) Jain Anil K, *Fundamentals of digital image processing*, PHI 1988
- 2) Kenneth R Castleman, *Digital image processing*, 2/e, Pearson Education, 2003
- 3) Pratt William K, *Digital Image Processing*, 4/e, John Wiley, 2007

vi) COURSE PLAN

Module	Contents	No. of hours
I	Digital image fundamentals: Image representation, basic relationship between pixels, elements of DIP system, elements of visual perception, simple image formation model. Vidicon and Digital Camera working principles, Brightness, contrast, hue, saturation, mach band effect. Colour image fundamentals-RGB, CMY, HIS models, 2D sampling, quantization.	9
II	Review of matrix theory - Row and column ordering- Toeplitz, Circulant and block matrix. 2D Image transforms: DFT, its properties, Walsh transform, Hadamard transform, Haar transform, DCT, KL transform and Singular Value Decomposition. Image Compression: Need for compression, Basics of lossless compression – bit plane coding, run length encoding and predictive coding, Basics of lossy compression – uniform and non-uniform quantization techniques used in image compression, Concept of transform coding, JPEG Image compression standard	9
III	Image enhancement - Spatial domain methods: point processing-intensity transformations, histogram processing, image subtraction, image averaging. Spatial filtering- smoothing filters, sharpening filters Frequency domain methods: low pass filtering, high pass filtering, homomorphic filter	9
IV	Image Restoration: Degradation model, Unconstraint restoration-Lagrange multiplier and constraint restoration Inverse filtering- removal of blur caused by uniform linear motion,	9



	Weiner filtering Geometric transformations-spatial transformations	
V	Image segmentation - Classification of Image segmentation techniques, region approach, clustering techniques Segmentation based on Thresholding, edge based segmentation Classification of edges, edge detection, Hough transform, active contour	9
	Total hours	45

vii) ASSESSMENT PATTERN**Mark distribution**

Total Marks	Continuous Internal Evaluation Marks	End Semester Evaluation Marks	End Semester Examination Duration
150	50	100	3 Hours

Continuous Internal Evaluation Pattern:

Attendance	10 Marks
Continuous Assessment Tests (2 numbers)	25 Marks
Assignment/Quiz/Course project	15 Marks

End Semester Examination Pattern:

There will be two parts; Part A and Part B. Part A contain 10 questions with 2 questions from each module, having 3 marks for each question. Students should answer all questions. Part B contains 2 questions from each module of which student should answer any one. Each question can have maximum 2 sub-divisions and carry 14 marks.



Course Code	Course Name	Category	L	T	P	Credit	Year of Introduction
EC1U31F	INTRODUCTION TO MEMS	PEC	2	1	0	3	2020

i) **PREREQUISITE:** ES0U10D Basics of Electrical and Electronics Engineering, ES0U10A Engineering Mechanics

ii) **COURSE OVERVIEW**

This course introduces students to the rapidly emerging, multi-disciplinary, and exciting field of Micro Electro Mechanical Systems.

iii) **COURSE OUTCOMES**

After the completion of the course, the student will be able to:

Course Outcomes	Description	Level
CO 1	Describe the working principles of micro sensors and actuators.	Understand
CO 2	Explain the commonly used mechanical structures in MEMS	Understand
CO 3	Explain the application of scaling laws in the design of micro systems.	Understand
CO 4	Describe the typical materials used for fabrication of micro systems.	Understand
CO 5	Explain the principles of standard micro fabrication techniques.	Understand
CO 6	Describe the challenges in the design and fabrication of Micro systems	Understand

iv) **SYLLABUS**

MEMS and Microsystems: Applications – multidisciplinary nature of MEMS – principles and examples of Micro sensors and micro actuators – micro accelerometer –comb drives - Micro grippers – micro motors, micro valves, micro pumps, Shape Memory Alloys.

Actuation and Sensing techniques: Thermal sensors and actuators, Electrostatic sensors and actuators, Piezoelectric sensors and actuators, magnetic actuators.

Review of Mechanical concepts: Stress, Strain, Modulus of Elasticity, yield strength, ultimate strength – General stress strain relations – compliance matrix. Overview of commonly used mechanical structures in MEMS - Beams, Cantilevers, Plates, Diaphragms – Typical applications Flexural beams: Types of Beams, longitudinal strain under pure bending – Deflection of beams – Spring constant of cantilever – Intrinsic stresses.

Scaling laws in miniaturization - scaling in geometry, scaling in rigid body dynamics, Trimmer force scaling vector, scaling in electrostatic and electromagnetic forces, scaling in electricity and fluidic dynamics, scaling in heat conducting and heat convection. **Materials for MEMS** – Silicon – Silicon compounds – Silicon Nitride, Silicon Dioxide, Silicon carbide, Poly Silicon, GaAs , Silicon Piezo resistors. **Polymers in MEMS** – SU-8, PMMA, PDMS, Langmuir – Blodgett Films.



Micro System fabrication – Photolithography – Ion implantation- Diffusion – Oxidation – Chemical vapour deposition – Etching Overview of Micro manufacturing – Bulk micro manufacturing, Surface micro machining , LIGA process –Microstereo lithography

Micro system Packaging: general considerations in packaging design – Levels of Micro system packaging. Bonding techniques for MEMS: Surface bonding, Anodic bonding, Silicon - on - Insulator, wire bonding, Sealing – Assembly of micro systems. Overview of MEMS areas : RF MEMS, BioMEMS, MOEMS, NEMS.

v) a) TEXT BOOKS

1. Chang Liu, *Foundations of MEMS*, Pearson, 2012
2. Tai-Ran Hsu, *MEMS and Microsystems Design and Manufacture*, TMH, 2002

b) REFERENCES

1. Chang C Y and Sze S. M., *VLSI Technology*, McGraw-Hill, New York, 2000
2. Julian W Gardner, *Microsensors: Principles and Applications*, John Wiley & Sons, 1994
3. Mark Madou, *Fundamentals of Micro fabrication*, CRC Press, New York, 1997
4. Stephen D. Senturia, *Microsystem design*, Springer (India), 2006.
5. Thomas B. Jones, *Electromechanics and MEMS*, Cambridge University Press, 2001
6. Gregory T.A. Kovacs, *Micromachined Transducers Sourcebook*, McGraw Hill, 1998

vi) COURSE PLAN

Module	Contents	No. of hours
I	MEMS and Microsystems: Applications – multidisciplinary nature of MEMS – principles and examples of Micro sensors and micro actuators – micro accelerometer –comb drives - Micro grippers – micro motors, micro valves, micro pumps, Shape Memory Alloys. Actuation and Sensing techniques: Thermal sensors and actuators, Electrostatic sensors and actuators, Piezoelectric sensors and actuators, magnetic actuators.	10
II	Review of Mechanical concepts: Stress, Strain, Modulus of Elasticity, yield strength, ultimate strength – General stress strain relations – compliance matrix. Overview of commonly used mechanical structures in MEMS - Beams, Cantilevers, Plates, Diaphragms – Typical applications. Flexural beams: Types of Beams, longitudinal strain under pure bending – Deflection of beams – Spring constant of cantilever – Intrinsic stresses.	10
III	Scaling laws in miniaturization - scaling in geometry, scaling in rigid body dynamics, Trimmer force scaling vector, scaling in electrostatic and electromagnetic forces, scaling in electricity and fluidic dynamics, scaling in heat conducting and heat convection. Materials for MEMS – Silicon – Silicon compounds – Silicon Nitride, Silicon Dioxide, Silicon carbide, Poly Silicon, GaAs , Silicon Piezo resistors. Polymers in MEMS – SU-8, PMMA, PDMS, Langmuir – Blodgett Films.	10
IV	Micro System fabrication – Photolithography – Ion implantation-Diffusion – Oxidation – Chemical vapour deposition – Etching Overview of Micro manufacturing – Bulk micro manufacturing, Surface	8



	micro machining , LIGA process –Microstereo lithography	
V	Micro system Packaging: general considerations in packaging design – Levels of Micro system packaging. Bonding techniques for MEMS: Surface bonding, Anodic bonding, Silicon - on - Insulator, wire bonding, Sealing – Assembly of micro systems. Overview of MEMS areas : RF MEMS, BioMEMS, MOEMS, NEMS	7
	Total hours	45

vii) ASSESSMENT PATTERN**Mark distribution**

Total Marks	Continuous Internal Evaluation Marks	End Semester Evaluation Marks	End Semester Examination Duration
150	50	100	3 Hours

Continuous Internal Evaluation Pattern:

Attendance	10 Marks
Continuous Assessment Tests (2 numbers)	25 Marks
Assignment/Quiz/Course project	15 Marks

End Semester Examination Pattern:

There will be two parts; Part A and Part B. Part A contain 10 questions with 2 questions from each module, having 3 marks for each question. Students should answer all questions. Part B contains 2 questions from each module of which student should answer any one. Each question can have maximum 2 sub-divisions and carry 14 marks.



Course Code	Course Name	Category	L	T	P	Credit	Year of Introduction
EC1U31G	QUANTUM COMPUTING	PEC	2	1	0	3	2020

i) **PREREQUISITE:** MA0U10A - Linear Algebra and Calculus

ii) **COURSE OVERVIEW**

Goal of this course is to have an understanding of the fundamentals of quantum computing, working of quantum computer and algorithms, quantum error corrections, designed for bigger quantum computers which are yet to be developed.

iii) **COURSE OUTCOMES**

After the completion of the course, the student will be able to

Course Outcomes	Description	Level
CO 1	Explain the basic constructs in linear algebra needed to build the concepts of quantum computing	Understand
CO 2	Illustrate/ demonstrate quantum measurement and quantum mechanics for computation	Understand
CO 3	Identify quantum gates and build quantum circuit model in which most of the quantum algorithms are designed	Apply
CO 4	Analyse and design quantum algorithms over classical counterparts	Analyze

iv) **SYLLABUS**

Basics of Linear Algebra - History and Overview of Quantum Computation and Quantum Information, Linear Algebra Basics.

Basics of Quantum Mechanics - State Space Representation - Bloch Sphere, State Evolution – Unitary transformation, Quantum measurement – Projective measurements, Composite systems - Superposition.

Quantum Gates and Circuits - Quantum gates – Hadamard gate, NOT gate, controlled-NOT gate, Toffoli gate, Realisation of classical gates with quantum gates – Z Gate

Quantum Measurement - Basic principle of quantum measurement - Principle of deferred measurement, Principle of implicit measurement

Algorithms - Quantum Fourier Transform (QFT) – Quantum circuit for QFT, Quantum phase estimation, Modular exponentiation, Order finding and factorization

v) a) **TEXT BOOKS**

- 1) M. A. Nielsen and I. L. Chuang, *Quantum Computation and Quantum Information*, a. 7/e, Cambridge University Press, 2010
- 2) J. Gruska, *Quantum Computing*, 12/e, McGraw Hill, 1999
- 3) G. Strang, *Linear algebra and its applications*, 4/e, Thomson, 2006
- 4)

**b) REFERENCES**

- 1) P. Kaye, R. Laflamme, and M. Mosca, *An Introduction to Quantum Computing*, 11/e, Oxford, 2007
- 2) Eleanor G. Rieffel, Wolfgang H. Polak, *Quantum Computing: A Gentle Introduction*, 3/e, MIT Press, 2011
- 3) Noson Yanofsky and Mirco Mucci, *Quantum Computing for Computer Scientists*, 4/e, Cambridge University Press, 2008
- 4) Abhijith, J., Adedoyin, Adetokunbo, Ambrosiano, John (and 30 others), *Quantum*
- 5) *Algorithm Implementations for Beginners*, 1/e, 2020

vi) COURSE PLAN

Module	Contents	No. of hours
I	Basics of Linear Algebra History and Overview of Quantum Computation and Quantum Information, Linear Algebra Basics, Linear Operators and matrices, The Pauli matrices, Inner Products, Eigen values and Eigen vectors, Hermitian operators and Adjoints, Spectral theorem, Tensor Products.	9
II	Basics of Quantum Mechanics State Space Representation - Bloch Sphere, State Evolution – Unitary transformation, Quantum measurement – Projective measurements, Composite systems - Superposition.	9
III	Quantum Gates and Circuits Quantum gates – Hadamard gate, NOT gate, controlled-NOT gate, Toffoli gate, Realisation of classical gates with quantum gates – Z Gate, Fredkein Gate, Pauli Matrices – Controlled Swap and Controlled U-operations, Circuit Identities	9
IV	Quantum Measurement Basic principle of quantum measurement - Principle of deferred measurement, Principle of implicit measurement, Gates with projective measurements, Universal quantum gates, Universality of two level unitary gates.	9
V	Algorithms Quantum Fourier Transform (QFT) – Quantum circuit for QFT, Quantum phase estimation, Modular exponentiation, Order finding and factorisation – Deutsch’s algorithm.	9
	Total hours	45

**vii) ASSESSMENT PATTERN****Mark distribution**

Total Marks	Continuous Internal Evaluation Marks	End Semester Evaluation Marks	End Semester Examination Duration
150	50	100	3 Hours

Continuous Internal Evaluation Pattern:

Attendance	10 Marks
Continuous Assessment Tests (2 numbers)	25 Marks
Assignment/Quiz/Course project	15 Marks

End Semester Examination Pattern:

There will be two parts; Part A and Part B. Part A contain 10 questions with 2 questions from each module, having 3 marks for each question. Students should answer all questions. Part B contains 2 questions from each module of which student should answer any one. Each question can have maximum 2 sub-divisions and carry 14 marks.



MINORS



Course Code	Course Name	Category	L	T	P	Credit	Year of Introduction
ECOM30D	VLSI Circuits	VAC (MINOR)	3	1	0	4	2020

i) **PREREQUISITE:** ECOM20A Electronic Circuits

ii) **COURSE OVERVIEW**

Goal of this course is to impart the knowledge about the fundamentals of Digital Systems, MOSFETs, basic VLSI circuits and Application Specific Integrated Circuits.

iii) **COURSE OUTCOMES**

After the completion of the course, the student will be able to

Course Outcomes	Description	Level
CO 1	Explain the working of various functional building blocks used in digital system design.	Understand
CO 2	Explain Structure and Working of MOSFETS and basic VLSI circuits using MOSFET.	Understand
CO 3	Explain the circuit technique used to implement dynamic logic and storage cells.	Understand
CO 4	Explain the application specific integrated circuit design flow and design approached.	Understand
CO 5	Explain the programmable logic cells, programming technologies, different type of i/o cells and different timing constraints in ASIC design.	Understand

iv) **SYLLABUS**

Basic logic gates, binary adder, subtractor, magnitude comparator, decoders, encoders, multiplexers, simple examples for combinational circuits (discuss with respective truth tables) Sequential circuits, Latched and flip-flops, clocked sequential circuits ,registers, shift registers, counters (analysis not required).

Structure and working principle of MOSFETS, VI characteristics, current equations(derivations not required),NMOS and CMOS inverter circuits, static characteristics and comparison, implementation of CMOS logic gates, stick diagram representation, Layout Design and Design rules- Lambda rules and micron rules (Definitions only).

Dynamic Logic Design-Pre charge- Evaluate logic, Domino Logic, NP domino logic. Read Only Memory-4x4 MOS ROM Cell Arrays (NOR) Random Access Memory –SRAM-Six transistor CMOS SRAM cell, DRAM –Three transistor and One transistor Dynamic Memory Cell.

Introduction Moores law .ASIC design, Full custom ASICs, Standard cell based ASICs, Gate array based ASICs, SoCs, FPGA devices, ASIC and FPGA Design flows Top-Down and Bottom-Up design methodologies. Logical and Physical design. Speed power and area considerations in VLSI design.

FPGA Architecture :Programmable logic cells: multiplexer based logic cells(ACT1), lookup table based logic implementation(XC3000 CLB), programmable array based logic implementation (Altera MAX).



ASIC programming technologies: antifuse, SRAM, EPROM, EEPROM Different types of I/O cells used in programmable ASICs

Timing constraints in ASIC design: setup time, hold time, propagation delay, clock to output delay, critical path (concept only).

v) a) TEXT BOOKS

1. M. Morris Mano, *Digital Design*, 3/e, Prentice Hall of India, 2002.
2. M. J. S. Smith, *Application Specific Integrated Circuits*, Pearson Education, 2007.
3. Jan M. Rabaey, *Digital Integrated Circuits- A Design Perspective*, Second Edition, Prentice Hall, 2005.

b) REFERENCES

1. Thomas Floyd, *Digital Fundamentals*, 11/e, Pearson Publication, 2015.
2. Neil H.E. Weste, Kamran Eshraghian, *Principles of CMOS VLSI Design - A Systems Perspective*, Second Edition. Pearson Publication, 2005.
3. Sung –Mo Kang & Yusuf Leblebici, *CMOS Digital Integrated Circuits - Analysis & Design*, McGraw-Hill, Third Ed., 2003.

vi) COURSE PLAN

Module	Contents	No. of hours
I	Basic Building Blocks in Digital Systems: Basic logic gates, binary adder, subtractor, magnitude comparator, decoders, encoders, multiplexers, simple examples for combinational circuits (discuss with respective truth tables) Sequential circuits, Latched and flip-flops, clocked sequential circuits ,registers, shift registers, counters (analysis not required).	12
II	MOSFET Fundamentals and basic VLSI circuits: Structure and working principle of MOSFETS, VI characteristics, current equations(derivations not required),NMOS and CMOS inverter circuits, static characteristics and comparison, implementation of CMOS logic gates, stick diagram representation, Layout Design and Design rules- Lambda rules and micron rules (Definitions only).	12
III	Dynamic logic Design and Storage Cells: Dynamic Logic Design-Pre charge- Evaluate logic, Domino Logic, NP domino logic. Read Only Memory-4x4 MOS ROM Cell Arrays (NOR) Random Access Memory –SRAM-Six transistor CMOS SRAM cell, DRAM –Three transistor and One transistor Dynamic Memory Cell.	12
IV	VLSI Design Methodologies: Introduction Moore s law .ASIC design, Full custom ASICs, Standard cell based ASICs, Gate array based ASICs, SoCs, FPGA devices, ASIC and FPGA Design flows Top-Down and Bottom-Up design methodologies. Logical and Physical design. Speed power and area considerations in VLSI design.	12
V	FPGA Architecture:Programmable logic cells: multiplexer based logic cells(ACT1), lookup table based logic implementation(XC3000 CLB),	12



	<p>programmable array based logic implementation (Altera MAX).</p> <p>ASIC programming technologies: antifuse, SRAM, EPROM, EEPROM Different types of I/O cells used in programmable ASICs.</p> <p>Timing constraints in ASIC design: setup time, hold time, propagation delay, clock to output delay, critical path (concept only).</p>	
	Total hours	60

vii) ASSESSMENT PATTERN**Mark distribution**

Total Marks	Continuous Internal Evaluation Marks	End Semester Evaluation Marks	End Semester Examination Duration
150	50	100	3 Hours

Continuous Internal Evaluation Pattern:

Attendance	10 Marks
Continuous Assessment Tests (2 numbers)	25 Marks
Assignment/Quiz/Course project	15 Marks

End Semester Examination Pattern:

There will be two parts; Part A and Part B. Part A contain 10 questions with 2 questions from each module, having 3 marks for each question. Students should answer all questions. Part B contains 2 questions from each module of which student should answer any one. Each question can have maximum 2 sub-divisions and carry 14 marks.



Course Code	Course Name	Category	L	T	P	Credit	Year of Introduction
ECOM30E	DATA NETWORKS	VAC (MINOR)	4	0	0	4	2020

i) COURSE OVERVIEW

Goal of this course is to provide an insight into the basic concepts of data communication and networking.

ii) COURSE OUTCOMES

After the completion of the course, the student will be able to

Course Outcomes	Description	Level
CO 1	Explain the concepts of data communication, structure of networks and compare OSI and TCP/IP networking models.	Understand
CO 2	Explain the responsibilities of the data link layer including framing, addressing, flow control, error control and media access control.	Understand
CO 3	Illustrate the functions and protocols of network layer, transport layer and application layer in inter-networking.	Apply
CO 4	Discuss congestion control techniques and Quality of Service requirements for a network.	Understand

iii) SYLLABUS

Data Communications- Components, Network criteria, Physical Structures, Switching, Categories of Networks, Interconnection of Networks, OSI Model, TCP/IP Protocol Suite, Physical Layer, Data Link Layer – Framing, Flow and Error Control, Error Correction and Detection, Networking Devices. Multiple Access Protocols, Ethernet, Wireless LANs, IPV4, IPV6, ARP, RARP, BOOTP, DHCP, Routing protocols, Transport Layer, Congestion Control & Quality of Service, Application Layer.

iv)a) TEXT BOOKS

- 1) Behrouz A Forouzan, *Data Communication and Networking*, 5/e, Tata McGraw Hill, 2012

b) REFERENCES

- 1) Andrew S. Tanenbaum, *Computer Networks*, 4/e, PHI (Prentice Hall India), 2002
- 2) William Stallings, *Computer Networking with Internet Protocols and technology*, Prentice-Hall, 2004
- 3) Fred Halsall, *Computer Networking and the Internet*, 5/e, Pearson Education, 2005.
- 4) Larry L Peterson and Bruce S Davie, *Computer Networks – A Systems Approach*, 5/e, Morgan Kaufmann, 2011
- 5) James F. Kurose, Keith W. Ross, *Computer Networking: A Top-Down Approach*, 6/e, Pearson Education, 2013



v) COURSE PLAN

Module	Contents	No. of hours
I	Data Communications- Components, Data representation, Data flow- Simplex, Half Duplex, Full Duplex Modes, Networks- Network criteria, Physical Structures- Point to Point Connection, Multipoint Connection, Physical Topology, Switching- Circuit Switched Networks and Datagram Networks, Categories of Networks, Interconnection of Networks, Protocols, Network models – OSI Model, Layers in the OSI Model, TCP/IP Protocol Suite.	12
II	Physical Layer and Data Link Layer: Guided Media and Unguided Transmission Media, Data Link Layer – Framing, Flow and Error Control - Stop and Wait Protocol, Sliding Window Protocol, Error Correction and Detection - Types of Errors, Redundancy, Detection vs Correction, Forward Error Correction vs Retransmission, Check Sum, Networking Devices- Hubs, Bridges, Switches.	12
III	Multiple Access, Ethernet, Wireless LANs: Multiple Access Protocols – Random Access, ALOHA, CSMA, CSMA/CD, CSMA/CA, Controlled Access, Channelization -FDMA, TDMA, CDMA, Ethernet - IEEE standards, Wireless LANs- IEEE 802.11, Bluetooth.	11
IV	Network Layer: Internetworking- Need for Network Layer, Internet as a Datagram Network, Internet as a Connectionless Network, Network Layer Logical Addressing – IPv4 and IPv6 Addressing only, Address Mapping -ARP, RARP, BOOTP, DHCP. Delivery, Forwarding, Routing Protocols - Distance Vector routing.	12
V	Transport Layer, Application layer: Transport layer – UDP, TCP, Congestion, Congestion Control, Quality of Service, Techniques to Improve QoS. Application Layer- FTP, Telnet, DNS, Electronic Mail.	13
	Total hours	60

vi) ASSESSMENT PATTERN

Mark distribution

Total Marks	Continuous Internal Evaluation Marks	End Semester Evaluation Marks	End Semester Examination Duration
150	50	100	3 Hours

**Continuous Internal Evaluation Pattern:**

Attendance	10 Marks
Continuous Assessment Tests (2 numbers)	25 Marks
Assignment/Quiz/Course project	15 Marks

End Semester Examination Pattern:

There will be two parts; Part A and Part B. Part A contain 10 questions with 2 questions from each module, having 3 marks for each question. Students should answer all questions. Part B contains 2 questions from each module of which student should answer any one. Each question can have maximum 2 sub-divisions and carry 14 marks.



Course Code	Course Name	Category	L	T	P	Credit	Year of Introduction
ECOM30F	TOPICS IN COMPUTER VISION	VAC (MINOR)	3	1	0	4	2020

i) COURSE OVERVIEW

This course aims to develop the knowledge of various methods, algorithms and applications of computer vision

ii) COURSE OUTCOMES

After the completion of the course, the student will be able to

Course Outcomes	Description	Level
CO 1	Apply basic point operators and 2D transforms for digital filtering operations	Apply
CO 2	Apply various algorithms for morphological operations and binary shape analysis.	Apply
CO 3	Describe the theoretical aspects of image formation models, projections and transformations in a 3D vision system.	Understand
CO 4	Explain different feature detection methods and optical flow algorithms to locate objects in-vision system.	Understand
CO 5	Explain the motion analysis of objects in a given scene using appropriate computer vision algorithms for real time applications.	Understand

iii) SYLLABUS

Review of image processing techniques: Filtering, Point operators-Histogram Based operators, neighbourhood operators, Thresholding - linear filtering – development of filtering masks - 2D Fourier transforms – filtering in frequency domain, Homomorphic filtering
Mathematical Operators: Binary shape analysis: Basics of Morphological operations, structuring element, Erosion, Dilation, Opening and Closing, Hit-or-Miss Transform, Connectedness, object labelling and counting , Boundary descriptors – Chain codes.

Camera models: Monocular and binocular imaging system, Orthographic and Perspective Projection, Image formation, geometric transformations, Camera Models (Basic idea only), 3D-Imaging system-Stereo Vision.

Feature Detection: Edge detection – edges, lines, active contours, Split and merge, Mean shift and mode finding, Normalized cuts, Graph cuts, energy-based and Canny's methods. Corner detection, Harris corner detection algorithm, Line and curve detection, Hough transform SIFT operators, Shape from X, Shape Matching, Structure from motion.

Motion Analysis- Regularization theory, Optical Flow: brightness constancy equation, aperture problem, Horn-Shunck method, Lucas-Kanade method. (Analysis not required) Object Detection and Object classification: SVM, Linear discriminant analysis, Bayes rule, ML. Face detection, Face Recognition, Eigen faces, 3D face models Applications of Computer Vision: Context and



scene understanding, Real Time applications: Locating road way and road marking, locating road signs and pedestrians.

iv)a) TEXT BOOKS

- 3) E. R .Davies, *Computer and Machine Vision -Theory Algorithm and Practicalities*, 4/e, Academic Press, 2012
- 4) Richard Szeliski, *Computer Vision: Algorithms and Applications*, ISBN 978-1- 84882-935-0, Springer 2011.
- 5) David Forsyth and Jean Ponce, *Computer Vision: A Modern Approach*,2/e, Pearson India, 2012

c) REFERENCES

- 1) Goodfellow, Bengio, and Courville, *Deep Learning*, MIT Press, 2016
- 2) Daniel LelisBaggio, KhvedcheniaIevgen, ShervinEmam, David MillanEscriva, NaureenMahmoo, Jason Saragi, Roy Shilkrot, *Mastering Open CV with Practical Computer Vision Projects*, Packt Publishing Limited, 2012
- 3) Simon J D Prince, *Computer Vision: Models, Learning, and Inference*, Cambridge University Press, 2012
- 4) Schalkoff, *Digital Image Processing and Computer Vision*, John Wiley, 2004.

v) COURSE PLAN

Module	Contents	No. of hours
1	Introduction, Review of image processing techniques: filtering, Point operators- Histogram, neighbourhood operators, thresholding– development of filtering masks, 2D Fourier transforms – filtering in frequency domain, homomorphic filtering	12
2	Mathematical Operators: Basics of Morphological operations, structuring element, Binary shape analysis: Erosion, Dilation, Opening and Closing, Hit-or-Miss Transform, Connectedness, object labelling and counting, Boundary descriptors –Chain Codes	12
3	Camera models - Monocular and binocular imaging system, Orthographic & Perspective Projection, Image formation, geometric transformations, camera Models(Basic idea only), 3D-Imaging system- Stereo Vision	10
4	Feature Detection: Edge detection – edges, lines, active contours, Split and merge, Mean shift and mode finding, Normalized cuts, Graph cuts, energy-based and Canny’s methods. Corner detection, Harris corner detection algorithm, Line and curve detection, Hough transform, SIFT operators, Shape from X, Shape Matching	12
5	Motion Analysis - Motion Analysis- Regularization theory, Optical Flow: brightness constancy equation, aperture problem, Horn-Shunck method, Lucas-Kanade method (Analysis not required) Object Detection and Object classification: SVM, Linear discriminant analysis, Bayes rule, maximum likelihood, Face detection, Face	14



	Recognition, Eigen faces, 3D face models Applications of Computer Vision: Context and scene understanding, Real Time applications: Locating road way and road marking, locating road signs and pedestrians	
	Total hours	60

vi) ASSESSMENT PATTERN**Mark distribution**

Total Marks	Continuous Internal Evaluation Marks	End Semester Evaluation Marks	End Semester Examination Duration
150	50	100	3 Hours

Continuous Internal Evaluation Pattern:

Attendance	10 Marks
Continuous Assessment Tests (2 numbers)	25 Marks
Assignment/Quiz/Course project	15 Marks

End Semester Examination Pattern:

There will be two parts; Part A and Part B. Part A contain 10 questions with 2 questions from each module, having 3 marks for each question. Students should answer all questions. Part B contains 2 questions from each module of which student should answer any one. Each question can have maximum 2 sub-divisions and carry 14 marks.



HONOURS



Course Code	Course Name	Category	L	T	P	Credit	Year of Introduction
EC1H30D	ELECTRONIC DESIGN AUTOMATION	VAC (HONOUR)	4	0	0	4	2020

i) COURSE OVERVIEW

Goal of this course is to introduce principles behind advanced methods in automation of electronic design.

ii) COURSE OUTCOMES

After the completion of the course, the student will be able to

Course Outcomes	Description	Level
CO 1	Determine various graph solutions using search algorithms and shortest path algorithms.	Apply
CO 2	Describe VLSI Design Flow and Design Styles and apply partitioning algorithms on graphs representing netlist.	Understand
CO 3	Illustrate Design Layout Rules and apply different algorithms for layout compaction.	Apply
CO 4	Determine solutions for placement and floorplan problems using various algorithms.	Apply
CO 5	Explain different algorithms to solve routing problems.	Understand

iii) SYLLABUS

Graph Terminology: Basic graph theory terminology, Data structures for representation of

Graphs Search Algorithms: Breadth First Search, Depth First Search, Topological Sort.

Shortest Path Algorithms: Dijkstra's Shortest-Path Algorithm for single pair shortest path, Floyd Warshall Algorithm for all pair shortest path.

Design Automation: VLSI Design Flow, VLSI Design Styles.

Partitioning: Levels of Partitioning, Parameters for Partitioning, Classification of Partitioning Algorithms, Kernighan-Lin Algorithm, Fiduccia-Mattheyses Algorithm, Simulated Annealing.

Layout: Layout Layers and Design Rules, Physical Design Optimizations.

Compaction: Applications of Compaction, Informal Problem Formulation, Graph Theoretical Formulation, Maximum Distance Constraints, Longest Path algorithm for DAG, Longest path in graph with cycles, Liao-Wong Algorithm, Bellman-Ford Algorithm.

Placement: Optimization Objectives, Wirelength Estimation, Weighted Wirelength, Maximum Cut Size, Wire Density.

Placement Algorithms: Quadratic Placement.

Floorplanning: Optimization Objectives, Slicing Floorplan, Non-Slicing Floorplan.

**Floorplan Representations:** Constraint Graph, Sequence Pair.**Floorplan Algorithms:** Minimum Area Algorithm.**Global Routing:** Terminology and Definitions, Optimization Goals, Representation of Routing Regions.**Maze Routing Algorithms:** Lee's Algorithm, Hadlock Algorithm.**Detailed Routing:** Horizontal and Vertical Constraint Graph.**Channel Routing Algorithms:** Left-Edge algorithm.**iv)a) TEXT BOOKS**

1. Jin Hu, Jens Lienig, Igor L. Markov, Andrew B. Kahng, *VLSI Physical Design: From Graph Partitioning to Timing Closure*, Springer, 2011
2. Gerez, Sabih H., *Algorithms for VLSI Design Automation*, John Wiley & Sons, 2006
3. Sherwani, Naveed A., *Algorithms for VLSI Physical Design Automation*, Kluwer Academic Publishers, 1999

d) REFERENCES

1. Sadiq M. Sait and H. Youssef, *VLSI Physical Design Automation: Theory and Practice*, World Scientific, 1999
2. Cormen, Thomas H., Charles E. Leiserson, and Ronald L. Rivest., *Introduction to Algorithms*, 3rd edition, The MIT Press, 2009

v) COURSE PLAN

Module	Contents	No. of hours
I	<p>Graph Terminology, Search Algorithms and Shortest Path Algorithms:</p> <p>Graph Terminology: Basic graph theory terminology, Data structures for representation of Graphs.</p> <p>Graphs Search Algorithms: Breadth First Search, Depth First Search, Topological Sort</p> <p>Shortest Path Algorithms: Dijkstra's Shortest-Path Algorithm for single pair shortest path, Floyd Warshall Algorithm for all pair shortest path</p>	12
II	<p>Design Automation and Partitioning Algorithms:</p> <p>Design Automation: VLSI Design Flow, VLSI Design Styles</p> <p>Partitioning: Levels of Partitioning, Parameters for Partitioning, Classification of Partitioning Algorithms, Kernighan-Lin Algorithm, Fiduccia-Mattheyses Algorithm, Simulated Annealing</p>	12



III	<p>Layout Compaction:</p> <p>Layout: Layout Layers and Design Rules, Physical Design Optimizations</p> <p>Compaction: Applications of Compaction, Informal Problem Formulation, Graph Theoretical Formulation, Maximum Distance Constraints, Longest Path algorithm for DAG, Longest path in graph with cycles, Liao-Wong Algorithm, Bellman-Ford Algorithm.</p>	12
IV	<p>Placement and Floor planning:</p> <p>Placement: Optimization Objectives, Wirelength Estimation, Weighted Wirelength, Maximum Cut Size, Wire Density</p> <p>Placement Algorithms: Quadratic Placement</p> <p>Floor planning: Optimization Objectives, Slicing Floorplan, Non-Slicing Floorplan</p> <p>Floorplan Representations: Constraint Graph, Sequence Pair</p> <p>Floorplan Algorithms: Minimum Area Algorithm</p>	12
V	<p>Global Routing and Detailed Routing:</p> <p>Global Routing: Terminology and Definitions, Optimization Goals, Representation of Routing Regions</p> <p>Maze Routing Algorithms: Lee's Algorithm, Hadlock Algorithm</p> <p>Detailed Routing: Horizontal and Vertical Constraint Graph</p> <p>Channel Routing Algorithms: Left-Edge algorithm</p>	12
	Total hours	60

vi) ASSESSMENT PATTERN

Mark distribution

Total Marks	Continuous Internal Evaluation Marks	End Semester Evaluation Marks	End Semester Examination Duration
150	50	100	3 Hours

Continuous Internal Evaluation Pattern:

Attendance	10 Marks
Continuous Assessment Tests (2 numbers)	25 Marks
Assignment/Quiz/Course project	15 Marks



End Semester Examination Pattern:

There will be two parts; Part A and Part B. Part A contain 10 questions with 2 questions from each module, having 3 marks for each question. Students should answer all questions. Part B contains 2 questions from each module of which student should answer any one. Each question can have maximum 2 sub-divisions and carry 14 marks.



Course Code	Course Name	Category	L	T	P	Credit	Year of Introduction
EC1H30E	MIMO & MULTIUSER COMMUNICATION SYSTEMS	VAC(HO NOUR)	4	0	0	4	2020

i) **PREREQUISITE:** MA0U20C - Probability and Random Process, EC1U30C - Analog and Digital Communication.

ii) COURSE OVERVIEW

MIMO systems are rising attention of the academic community and industry because of their potential to increase to capacity and diversity gain proportionally with the number of antennas. OFDM is a promising solution to mitigate the effect of inter symbol interference (ISI) and multipath fading. MIMO OFDM is an attractive air interface solution for multiuser communication and effectively deployed in wireless local area networks, fifth Generation (5G) wireless cellular standards.

iii) COURSE OUTCOMES

After the completion of the course, the student will be able to

Course Outcomes	Description	Level
CO 1	Describe digital communication over multipath channels.	Understand
CO 2	Analyse the performance of multiuser communication techniques over generalized fading channel.	Apply
CO 3	Describe the concept of MIMO systems and determine the capacity of MIMO channel	Apply
CO 4	Explain OFDM and associated timing and frequency synchronization in MIMO receiver	Understand
CO 5	Explain the theory of MIMO multiuser communication systems.	Understand

iv) SYLLABUS

Digital Communication over Fading Multipath Channels Characterization of fading multipath channels, Statistical model for fading channels (Rayleigh and Rice distribution), Relation between channel correlation and Power spectral density, Signal characteristics on the choice of channel model (frequency selective and frequency nonselective fading), Frequency nonselective slowly fading channel, Frequency selective slowly fading channel, Fast fading, Rake receiver.

Multiuser Communications Types of multiple access techniques, Capacity of multiple access methods (Inference only). Single user and multiuser detection, CDMA signal and channel model, CDMA optimum receiver (Synchronous transmission, Asynchronous transmission), Suboptimum detectors (Single user detector and Decorrelation receiver). Practical applications of multiple access techniques.

MIMO System Signal and channel model for SISO, SIMO, MISO and MIMO, Capacity of frequency flat deterministic MIMO channel (both channel unknown and known to the transmitter), SIMO channel capacity, MISO channel capacity, Capacity of random MIMO



channels, Ergodic capacity, Outage capacity, Capacity of frequency selective MIMO channels (both channel unknown and known to the transmitter).

Diversity and Receiver Array gain, Diversity gain, Spatial multiplexing, Receive antenna diversity, Transmit antenna diversity, SISO receiver (MLSE, ZF and Decision feedback equalizer), SIMO receiver, MIMO receiver (both Optimal and suboptimal), Sphere decoding.

Review of AWGN channel and band limited ISI channel, Introduction to multicarrier systems, FFT based multicarrier system, Mitigation of subcarrier fading, SISO-OFDM, MIMO-OFDM, Coarse time synchronization, Fine time synchronization, Coarse frequency synchronization, OFDMA, Wireless standards (WiMAX, and 3GPP LTE)

v) a) TEXT BOOKS

1. John G Proakis, *Digital Communications*, 4/e, McGraw-Hill, 2014
2. David Tse and Pramod Viswanath, *Fundamentals of Wireless Communications*, Cambridge University Press, 2005
3. A Paulraj, Nabar and D Gore, *Introduction to Space Time Wireless Communications*, Cambridge University Press, 2003
4. Y S Cho, J Kim, Won Yong Yang, Chung G Kang, *MIMO OFDM Wireless Communications with MATLAB*, John Wiley & sons private Ltd, 2010

b) REFERENCES

1. Erik G Larsson, *Space Time Block Coding for Wireless Communications*, Cambridge University Press, 2003
2. E Biglieri, R Calderbank, A Constantinides, A Goldsmith, A Paulraj, *MIMO Wireless Communications*, Cambridge University Press
3. Simon Haykin, *Digital Communications*, John Wiley & Sons Pvt Ltd. 2001
4. Andrea Goldsmith, *Wireless Communications*, Cambridge University Press, 2005

vi) COURSE PLAN

Module	Contents	No. of hours
I	Multipath fading, Coherence time, Coherence bandwidth, Doppler spread, Characterization of fading multipath channels, Statistical model for fading channels (Rayleigh and Rice distribution), Relation between channel correlation and Power spectral density, Signal characteristics on the choice of channel model (frequency selective and frequency nonselective fading), Frequency nonselective slowly fading channel, Frequency selective slowly fading channel, Fast fading, Rake receiver	13
II	Types of multiple access techniques (FDMA, TDMA and CDMA), Capacity of multiple access methods (without proof, Inference only), Single user detection, Multiuser detection, CDMA signal and channel model, CDMA optimum receiver (Synchronous transmission, Asynchronous transmission), Suboptimum detectors (Single user detector and Decorrelation receiver). Practical applications of multiple access techniques.	11



III	Signal and channel model for SISO, SIMO, MISO and MIMO, Capacity of frequency flat deterministic MIMO channel (both channel unknown and known to the transmitter), SIMO channel capacity, MISO channel capacity, Capacity of random MIMO channels, Ergodic capacity, Outage capacity, Capacity of frequency selective MIMO channels (both channel unknown and known to the transmitter)	12
IV	Array gain, Diversity gain, Spatial multiplexing. Receive antenna diversity, Transmit antenna diversity, SISO receiver (MLSE, ZF and Decision feedback equalizer), SIMO receiver, MIMO receiver (both Optimal and suboptimal), Sphere decoding.	11
V	Review of AWGN channel and band limited ISI channel, Introduction to multicarrier systems, FFT based multicarrier system, Mitigation of subcarrier fading, SISO-OFDM, MIMO-OFDM, Coarse time synchronization, Fine time synchronization, Coarse frequency synchronization, OFDMA, Wireless standards (WiMAX, and 3GPP LTE)	13
	Total hours	60

vii) ASSESSMENT PATTERN**Mark distribution**

Total Marks	Continuous Internal Evaluation Marks	End Semester Evaluation Marks	End Semester Examination Duration
150	50	100	3 Hours

Continuous Internal Evaluation Pattern:

Attendance	10 Marks
Continuous Assessment Tests (2 numbers)	25 Marks
Assignment/Quiz/Course project	15 Marks

End Semester Examination Pattern:

There will be two parts; Part A and Part B. Part A contain 10 questions with 2 questions from each module, having 3 marks for each question. Students should answer all questions. Part B contains 2 questions from each module of which student should answer any one. Each question can have maximum 2 sub-divisions and carry 14 marks.



Course Code	Course Name	Category	L	T	P	Credit	Year of Introduction
EC1H30F	DETECTION AND ESTIMATION THEORY	VAC(HO NOUR)	3	1	0	4	2020

i) **PREREQUISITE:**MA0U10A - Linear Algebra and Calculus, MA0U20C - Probability, Random Process, and Numerical Methods, ECT 204 - Signals and Systems

i) **COURSE OVERVIEW:**

Goal of this course is to provide an insight into the fundamentals of detection and estimation theory in engineering applications.

ii) **COURSE OUTCOMES**

After the completion of the course, the student will be able to

Course Outcomes	Description	Level
CO 1	Describe the fundamentals of statistical detection and estimation principles used in various engineering problems	Understand
CO 2	Apply various types of statistical decision rules in engineering applications.	Apply
CO 3	Apply different types of estimation methods in engineering applications.	Apply

iii) **SYLLABUS**

Fundamentals of detection and estimation theory and its applications, classical and Bayesian approach in detection and estimation theory, different types of statistical decision rules, different types of estimation algorithms and its applications.

iv) a) **TEXT BOOKS**

1. S.M. Kay, *Fundamentals of Statistical Signal Processing, Vol I: Estimation Theory*, 3/e, Pearson, 2010.
2. S.M. Kay, *Fundamentals of Statistical Signal Processing Vol II: Detection Theory*, 3/e, Pearson, 2010.

**b) REFERENCES**

1. H. L. Van Trees, *Detection, Estimation, and Modulation Theory*, Vol. I, John Wiley & Sons, 1968
2. Monson H. Hayes, *Statistical Digital Signal Processing and Modelling*, John Wiley & Sons, 2002.

v) COURSE PLAN

Module	Contents	No. of hours
I	Fundamentals of detection theory, the mathematical detection problem. Fundamentals of estimation theory, the mathematical estimation problem. Review of Gaussian distribution. Application examples.	11
II	Hypothesis testing, classical approach, Neyman-Pearson theorem, likelihood ratio test, receiver operating characteristics, Bayesian approach, minimum probability of error, Bayes risk, multiple hypothesis testing.	13
III	Detection of deterministic signals, matched filters, detection of random signals, estimator-correlator, linear model, application examples.	11
IV	Minimum variance unbiased estimation, basics of Cramer-Rao Lower Bound, linear models, best linear unbiased estimation, application examples.	13
V	Maximum likelihood estimation, least squares, Bayesian philosophy, minimum mean square error estimation, application examples.	12
	Total hours	60

**vi) ASSESSMENT PATTERN****Mark distribution**

Total Marks	Continuous Internal Evaluation Marks	End Semester Evaluation Marks	End Semester Examination Duration
150	50	100	3 Hours

Continuous Internal Evaluation Pattern:

Attendance	10 Marks
Continuous Assessment Tests (2 numbers)	25 Marks
Assignment/Quiz/Course project	15 Marks

End Semester Examination Pattern:

There will be two parts; Part A and Part B. Part A contain 10 questions with 2 questions from each module, having 3 marks for each question. Students should answer all questions. Part B contains 2 questions from each module of which student should answer any one. Each question can have maximum F2 sub-divisions and carry 14 marks.



SEMESTER VII



Course Code	Course Name	Category	L	T	P	Credit	Year of Introduction
EC1U40A	MICROWAVES AND ANTENNAS	PCC	2	1	0	3	2020

i) **PREREQUISITE:** EC1U30E- Electromagnetics

ii) COURSE OVERVIEW

This course aims to impart knowledge on the basic parameters of antenna, design and working of various broadband antennas, arrays and its radiation patterns. It also introduces various microwave sources, their principle of operation and study of various microwave hybrid circuits and microwave semiconductor devices.

iii) COURSE OUTCOMES

After the completion of the course, the student will be able to:

Course Outcomes	Description	Level
CO 1	Explain the basic concepts of antenna and its parameters.	Understand
CO 2	Analyse the far field pattern of short dipole and far field dipole antenna.	Apply
CO 3	Design of various broadband antennas, arrays and its radiation pattern.	Apply
CO 4	Analyse the principle of operation of cavity resonators, various microwave sources and microwave amplifier.	Apply
CO 5	Explain the S matrix formulation of various microwave hybrid circuits and operation of microwave semiconductor devices.	Understand

iv) SYLLABUS

Basic antenna parameters: gain, directivity, beam width and effective aperture calculations, effective height, wave polarization, radiation resistance, radiation efficiency, radiation pattern, antenna field zones. Duality and Principles of reciprocity, Field, directivity and radiation resistance of a short dipole and half wave dipole (far field derivation).

Broad band antenna: Principle of Log periodic antenna array and design, helical antenna: types and design. Design of Microstrip Rectangular Patch antennas and feeding methods. Principles of Horn, Parabolic dish antenna (expression for E, H and Gain without derivation), Mobile phone antenna – Inverted F antenna.

Arrays of point sources: field of two isotropic point sources, principle of pattern multiplication, linear arrays of 'n' isotropic point sources. Array factor, Grating lobes, Design of Broadside, End fire and Dolph Chebyshev arrays. Concept of Phase array.

Microwaves: Introduction, advantages, Cavity Resonators-Derivation of resonance frequency of Rectangular cavity. Single cavity klystron-Reflex Klystron Oscillators: Derivation of Power output, efficiency and admittance. Magnetron oscillators: Cylindrical magnetron, Cyclotron angular frequency, Power output and efficiency. Travelling Wave Tube: Slow wave structures,



Helix TWT, Amplification process, Derivation of convection current, axial electric field, wave modes and gain.

Microwave Hybrid circuits: Scattering parameters, Waveguide Tees-Magic tees, Hybrid rings, Formulation of S-matrix. Directional couplers: Two hole directional couplers, S-matrix. Circulators and Isolators, Phase Shifter.

Microwave Semiconductor Devices: Amplifiers using MESFET. Principle of Gunn diodes: Different modes, Principle of operation Gunn Diode Oscillators.

v) a) **TEXT BOOKS**

- 1) Balanis, Antenna Theory and Design, 3/e, Wiley Publications.
- 2) John D. Krauss, Antennas for all Applications, 3/e, TMH.
- 3) K D Prasad, Antenna and Wave Propagation, Satyaprakash Publications
- 4) Samuel Y. Liao, Microwave Devices and Circuits, 3/e, Pearson Education, 2003.
- 5) Robert E. Collin, Foundation of Microwave Engineering, 2/e, Wiley India, 2012.

b) **REFERENCES**

- 1) Collin R.E, Antennas & Radio Wave Propagation, McGraw Hill. 1985.
- 2) Jordan E.C. & K. G. Balmain, Electromagnetic Waves & Radiating Systems, 2/e, PHI.
- 3) Raju G.S.N., Antenna and Wave Propagation, Pearson, 2013.
- 4) Sisir K. Das & Annapurna Das, Antenna and Wave Propagation, McGraw Hill, 2012
- 5) Thomas A. Milligan, Modern Antenna Design, IEEE PRESS, 2/e, Wiley Inter science.
- 6) Das, Microwave Engineering, 3/e, McGraw Hill Education India Education, 2014
- 7) David M. Pozar, Microwave Engineering, 4/e, Wiley India, 2012.

vi) **COURSE PLAN**

Module	Contents	No. of hours
I	Basic antenna parameters (all parameters and related simple problems), Relation between parameters (derivation required) Principles of reciprocity (proof required), Duality. Concept of retarded potential, Derivation of Field, directivity and radiation resistance of a short dipole, Derivation of Field, directivity and radiation resistance of a half wave dipole.	10
II	Principle of Log periodic antenna array and design, Helical antenna: types and design, Design of Rectangular Patch antennas and feeding techniques, Principles of Horn, Parabolic dish antenna, (expression for E, H, G without derivation). Mobile phone antenna-Inverted F antenna.	7
III	Arrays of point sources, field of two isotropic point sources, principle of pattern multiplication Linear arrays of 'n' isotropic point sources. Grating lobes. Array factor (derivation) Design of Broadside, End fire and Dolph Chebyshev arrays. Concept of Phase array.	10
IV	Microwaves: Introduction, advantages, Cavity Resonators-Types,	10



	Derivation of resonance frequency of Rectangular cavity (problems required) Single cavity klystron- Reflex Klystron Oscillators: Derivation of Power output, efficiency and admittance.(problems required) Magnetron oscillators: Cylindrical magnetron, Cyclotron angular frequency, Power output and efficiency.(problems required) Travelling Wave Tube: Slow wave structures, Helix TWT, Amplification process, Derivation of convection current, axial electric field, wave modes and gain. (problems required)	
V	Microwave Hybrid circuits: Scattering parameters, Waveguide Tees-Magic tees, Hybrid rings. Formulation of S-matrix. Directional couplers: Two hole directional couplers, S-matrix. Circulators and Isolators. Phase Shifter. Microwave Semiconductor Devices: Principle of Gunn diodes: Different modes, Principle of operation Gunn Diode Oscillators.	8
	Total hours	45

vii) ASSESSMENT PATTERN**Mark distribution**

Total Marks	Continuous Internal Evaluation Marks	End Semester Evaluation Marks	End Semester Examination Duration
150	50	100	3 Hours

Continuous Internal Evaluation Pattern:

Attendance	10 Marks
Continuous Assessment Tests (2 numbers)	25 Marks
Assignment/Quiz/Course project	15 Marks

Simulation Assignments

The following simulation assignments can be done with MATLAB/HFSS/CST Microwave Studio or any Open software.

Simulation of radiation pattern of

- Microstrip patch antenna
- Arrays
- Helical antenna

End Semester Examination Pattern:

There will be two parts; Part A and Part B. Part A contain 10 questions with 2 questions from each module, having 3 marks for each question. Students should answer all questions. Part B contains 2 questions from each module of which student should answer any one. Each question can have maximum 2 sub-divisions and carry 14 marks.



Course Code	Course Name	Category	L	T	P	Credit	Year of Introduction
NC0U40A	INDUSTRIAL SAFETY ENGINEERING	MNC	2	1	0	--	2020

i) COURSE OVERVIEW

The course is intended to give knowledge of various safety management principles, various safety systems, various machine guarding devices, hazard identification techniques, energy sources, systems & applications and the need in the present context. Learners will be able to compare different hazard identification tools and choose the most appropriate based on the nature of industry. It aims to equip students in working with projects and to take up research work in connected areas

ii) COURSE OUTCOMES

After the completion of the course, the student will be able to:

Course Outcomes	Description	Level
CO 1	Explain the theories of accident causation and preventive measures of industrial accidents.	Understand
CO 2	Explain about personal protective equipment, its selection, safety performance & indicators and importance of housekeeping.	Understand
CO 3	Explain different issues in construction industries.	Understand
CO 4	Explain various hazards associated with different machines and mechanical material handling.	Understand
CO 5	Apply the knowledge of chemical hazards while utilizing hazard identification tools in various industries	Apply

ii) SYLLABUS

Need for safety. Safety and productivity. Definitions - Safety organization- Safety Officer- Safety committee Personal protection in the work environment, Types of PPEs- Monitoring Safety Performance- Housekeeping -Work permit system Introduction to construction industry and safety issues in construction Safety in various construction operations – Excavation and filling – Under-water works – Under-pinning & Shoring – Ladders & Scaffolds – Tunneling – Blasting – Demolition – Confined space – Temporary Structures. Familiarization with relevant Indian Standards and the National Building Code provisions on construction safety, Ergonomics Hazards Machinery safeguard , Safety in turning, and grinding. Welding and Cutting, Material Handling-Classification, Material Handling equipment, Hazard and risk, Types of hazards, Fire and explosion hazard rating of process plants - The Dow Fire and Explosion Hazard Index, Preliminary hazard analysis, Hazard and Operability study (HAZOP)),Material Safety Data Sheets (MSDS).

iii) (a) TEXTBOOKS

1. R.K Jain (2000) *Industrial Safety*, Health and Environment management systems, Khanna Publications.
2. Paul S V (2000), *Safety management System and Documentation training Programme handbook*, CBS Publication.
3. Krishnan, N.V. (1997). *Safety management in Industry*. Jaico Publishing House, New Delhi.
4. John V. Grimaldi and Rollin H.Simonds. (1989) *Safety management*. All India Traveller Book Seller, Delhi.

**(c) REFERENCES**

1. Ronald P. Blake. (1973). *Industrial safety*. Prentice Hall, New Delhi.
2. Alan Waring. (1996). *Safety management system*. Chapman & Hall, England.
3. Vaid, K.N., (1988). *Construction safety management*. National Institute of Construction Management and Research, Mumbai.
4. AIChE/CCPS. (1992). *Guidelines for Hazard Evaluation Procedures*. (second edition). Centre for Chemical Process Safety, American Institute of Chemical Engineers, New York.

iv) COURSE PLAN

Module	Contents	No. of hours
I	<p>Need for safety. Safety and productivity. Definitions: Accident, Injury, Unsafe act, Unsafe Condition, Dangerous Occurrence, Reportable accidents. Theories of accident causation.</p> <p>Safety organization- objectives, types, functions, Role of management, supervisors, workmen, unions, government and voluntary agencies in safety. Safety policy. Safety Officer-responsibilities, authority. Safety committee-need, types, advantages.</p>	8
II	<p>Personal protection in the work environment, Types of PPEs, Personal protective equipment respiratory and non-respiratory equipment. Standards related to PPEs.</p> <p>Monitoring Safety Performance: Frequency rate, severity rate, incidence rate, activity rate.</p> <p>Housekeeping: Responsibility of management and employees. Advantages of good housekeeping. 5 s of housekeeping. Work permit system- objectives, hot work and cold work permits. Typical industrial models and methodology. Entry into confined spaces.</p>	10
III	<p>Introduction to construction industry and safety issues in construction Safety in various construction operations – Excavation and filling – Under-water works – Under-pinning & Shoring – Ladders & Scaffolds – Tunneling – Blasting – Demolition – Confined space – Temporary Structures.</p> <p>Familiarization with relevant Indian Standards and the National Building Code provisions on construction safety. Relevance of ergonomics in construction safety. Ergonomics Hazards - Musculoskeletal Disorders and Cumulative Trauma Disorders.</p>	9
IV	<p>Machinery safeguard - Point-of-Operation, Principle of machine guarding -types of guards and devices. Safety in turning, and grinding. Welding and Cutting-Safety Precautions of Gas welding and Arc Welding.</p> <p>Material Handling-Classification-safety consideration- manual and mechanical handling. Handling assessments and techniques- lifting, carrying, pulling, pushing, palletizing and stocking. Material Handling equipment-operation & maintenance. Maintenance of common elements- wire rope, chains slings, hooks, clamps. Hearing Conservation Program in Production industries.</p>	9



V	Hazard and risk, Types of hazards –Classification of Fire, Types of Fire extinguishers, fire explosion and toxic gas release, Structure of hazard identification and risk assessment. Identification of hazards: Inventory analysis.	9
	Fire and explosion hazard rating of process plants - The Dow Fire and Explosion Hazard Index, Preliminary hazard analysis, Hazard and Operability study (HAZOP) – methodology, criticality analysis, corrective action and follow-up. Control of Chemical Hazards, Hazardous properties of chemicals, Material Safety Data Sheets (MSDS).	
	Total hours	45

vi) ASSESSMENT PATTERN**Mark distribution**

Total Marks	Continuous Internal Evaluation Marks	End Semester Evaluation Marks	End Semester Examination Duration
150	50	100	3 Hours

Continuous Internal Evaluation Pattern:

Attendance	10 Marks
Continuous Assessment Tests (2 numbers)	25 Marks
Assignment/Quiz/Course project	15 Marks

Internal Examination Pattern:

Each of the two internal examinations has to be conducted out of 50 marks. First series test shall be preferably conducted after completing the first half of the syllabus and the second series test shall be preferably conducted after completing remaining part of the syllabus. There will be two parts: Part A and Part B. Part A contains 5 questions (preferably, 2 questions each from the completed modules and 1 question from the partly completed module), having 3 marks for each question adding up to 15 marks for part A. Students should answer all questions from Part A. Part B contains 7 questions (preferably, 3 questions each from the completed modules and 1 question from the partly completed module), each with 7 marks. Out of the 7 questions, a student should answer any 5.

End Semester Examination Pattern:

There will be two parts; Part A and Part B. Part A contain 10 questions with 2 questions from each module, having 3 marks for each question. Students should answer all questions. Part B contains 2 questions from each module of which student should answer



Course Code	Course Name	Category	L	T	P	Credit	Year of Introduction
EC1U48A	ELECTROMAGNETICS LAB	PCC	0	0	3	2	2020

i) **PREREQUISITE:** Nil

ii) **COURSE OVERVIEW:** This course aims to

(i) Provide practical experience in design and analysis of few electronic devices and circuits used for Microwave and Optical communication engineering.

(ii) Familiarize students with simulation of basic Antenna experiments with simulation tools.

iii) **COURSE OUTCOMES**

After the completion of the course, the student will be able to

Course Outcomes	Description	Level
CO 1	Plot the characteristics of a Gunn diode and Reflex klystron.	Apply
CO 2	Measure the parameters of various microwave components.	Apply
CO 3	Plot the VI characteristics of various optical active devices.	Apply
CO 4	Assemble Optical fiber Digital link to evaluate the numerical aperture and different kind of signal losses in an optical fiber.	Apply
CO 5	Design basic antenna experiments with simulation tools.	Apply
CO 6	Plot the radiation pattern of a given antenna using microwave bench setup.	Apply

iv) **SYLLABUS**

Microwave Experiments

1. Verify the relation $\lambda_c = 2a$.
2. Find the unknown impedance of the given load using Transmission line equation and verify using Smith chart.
3. Find the coupling coefficient of the given Directional Coupler.
4. Plot the mode characteristics of Reflex Klystron and Gunn diode.
5. Measure the characteristics of Magic Tee, Crystal index, and VSWR of a transmission line



Optical Experiments

1. Find the numerical aperture and V number of the given fiber.
2. Obtain the bending loss and attenuation loss of the given fiber.
3. Plot the V-I characteristics of Laser diode, LED and photodiode.

Antenna Experiments

1. Familiarization of any antenna simulation software.
2. Simulation of antennas and arrays.
3. Study of Vector Network Analyzer.
4. Antenna Pattern Measurement

v) a) TEXTBOOK

1. Samuel Y. Liao, Microwave Devices and Circuits, 3/e, Pearson Education, 2003.
2. Gred Keiser Optical Fiber Communication 5/e Mc Graw Hill, 2013
3. Balanis, Antenna Theory and Design, 3/e, Wiley Publications.

b) REFERENCES

1. John D. Krauss, Antennas for all Applications, 3/e, TMH.
2. Thomas A. Milligan, Modern Antenna Design, IEEE PRESS, 2/e, Wiley Inter science.
3. N.O. Sadiku and S.V. Kulkarni, *Principles of Electromagnetics*, Sixth Edition, Oxford University Press, India, 2015 (Asian adaptation of 'M.N.O. Sadiku, Elements of Electromagnetics, Sixth International Edition, Oxford University Press

COURSE PLAN

Experiment No.	List of exercises/experiments	No. of hours
I	MICROWAVE EXPERIMENTS (Minimum Four Experiments are mandatory) 1. Reflex Klystron Mode Characteristics. 2. GUNN diode characteristics. 3. VSWR and Frequency measurement. 4. Verify the relation between Guide wave length, free space wave length and cut off wave length for rectangular wave guide. 5. Unknown load impedance measurement using smith chart and verification using transmission line equation. 6. Measurement of Magic Tee characteristics. 7. Directional Coupler Characteristics.	12



	8. Crystal Index Measurement.	
II	OPTICAL EXPERIMENTS (Minimum Three Experiments are mandatory) 1. Setting up of Fiber optic Digital link. 2. Measurement of Numerical Aperture of a fiber. 3. Study of losses in Optical fiber. 4. Voltage vs. Current (V-I) characteristics of Laser Diode. 5. Voltage vs. Current (V-I) characteristics of LED. 6. Characteristics of Photodiode	9
III	ANTENNA EXPERIMENTS (Minimum Three Experiments are mandatory) 1. Familiarization of any antenna simulation software. 2. Simulation of Dipole Antenna. 3. Simulation of Patch Antenna. 4. Simulation of Antenna Array. 5. Study of Vector Network Analyzer. 6. Antenna Pattern Measurement Simulation experiments can be done with MATLAB/HFSS/CST Microwave Studio or any Open software.	9
	Total hours	30

vi) ASSESSMENT PATTERN

Mark distribution

Total Marks	Continuous Internal Evaluation Marks	End Semester Evaluation Marks	End Semester Examination Duration
150	75	75	3 Hours

Continuous Internal Evaluation Pattern:

Attendance	15 Marks
Continuous Assessment	30 Marks
Internal Test (Immediately before the II internal test)	30 Marks



End Semester Examination Pattern:

Preliminary work	15 marks
Implementing the work/Conducting the experiment	20 marks
Performance, result and inference (usage of equipment and troubleshooting):	15 marks
Viva voce	20 marks
Record	5 Marks



PROGRAMME ELECTIVE-II

Course Code	Course Name	Category	L	T	P	Credit	Year of Introduction
EC1U41A	OPTICAL FIBER COMMUNICATION	PEC	3	0	0	3	2020

i) **PREREQUISITE:** Nil

ii) **COURSE OBJECTIVES**

- To introduce the concepts of light transmission through optical fibers, optical sources and detectors
- To compare the performance of various optical transmission schemes
- To understand the working of optical components, principle of operation of optical amplifiers.
- To understand WDM technique.

iii) **COURSE OVERVIEW**

This course aims to introduce the concepts of light transmission through optical fibers and introduce the working of optical components.

iv) **COURSE OUTCOMES**

After the completion of the course, the student will be able to:

Course Outcomes	Description	Level
CO 1	Explain the working and classification of optical fibers in terms of propagation modes	Understand
CO 2	Solve problems of transmission characteristics and losses in optical fiber	Apply
CO 3	Explain the constructional features and the characteristics of optical sources and detectors	Understand
CO 4	Describe the operations of optical amplifiers	Understand
CO 5	Explain the concepts of WDM, FSO and LiFi	Understand

v) **SYLLABUS**

Optical fiber Communications: The general system, Advantages of optical fiber communication, Optical fiber waveguides: Ray theory transmission, Modes in planar guide, Phase and group velocity **Fibres:** Types and refractive index profiles, Step index fibers, Graded index fibers, Single mode fibers, Cutoff wavelength, Mode field diameter, effective refractive index. Fibre materials, photonic crystal fibre, index guiding PCF, photonic band-gap fibres, fibre cables.



Transmission characteristics of optical fiber: Attenuation, Material absorption losses, Linear scattering losses, Nonlinear scattering losses, Fiber bend loss, Dispersion, Chromatic dispersion, Intermodal dispersion: Multimode step index fiber.

Optical Fiber Connectors: Fiber alignment and joint loss, Fiber splices, Fiber connectors, Fiber couplers.

Optical sources: LEDs and LDs, structures, characteristics, modulators using LEDs and LDs. coupling with fibres, noise in Laser diodes, Amplified Spontaneous Emission noise, effects of Laser diode noise in fibre communications

Optical detectors: Types and characteristics, structure and working of PIN and AP, noise in detectors, comparison of performance. Optical receivers, Ideal photo receiver and quantum limit of detection.

Optical Amplifiers: basic concept, applications, types, doped fibre amplifiers, EDFA, basic theory, structure and working, Semiconductor laser amplifier, Raman amplifiers, TDFA, amplifier configurations, performance comparison.

The WDM concept, WDM standards, WDM components, couplers, splitters, Add/ Drop multiplexers, gratings, tunable filters. Introduction to free space optics, LiFi technology and VLC. Optical Time Domain Reflectometer (OTDR) – fault detection length and refractive index measurements.

vi) a) TEXT BOOKS

1. Gerd Keiser, Optical Fiber Communications, 5/e, McGraw Hill, 2013.
2. Mishra and Ugale, Fibre optic Communication, Wiley, 2013.

b) REFERENCES

1. Chakrabarthi, Optical Fibre Communication, McGraw Hill, 2015.
2. Hebbbar, Optical fibre communication, Elsevier, 2014
3. John M Senior- Optical communications, 3/e, Pearson, 2009.
4. Joseph C. Palais, Fibre Optic Communications, 5/e Pearson, 2013.
5. Keiser, Optical Communication Essentials (SIE), 1/e McGraw Hill Education New Delhi, 2008



vii) COURSE PLAN

Module	Contents	No. of hours
I	Optical fiber Communications: The general system, Advantages of optical fiber communication, Optical fiber waveguides: Ray theory transmission, Modes in planar guide, Phase and group velocity Fibres: Types and refractive index profiles, Step index fibers, Graded index fibers, Single mode fibers, Cutoff wavelength, Mode field diameter, effective refractive index. Fibre materials, photonic crystal fibre, index guiding PCF, photonic band-gap fibres, fibre cables.	10
II	Transmission characteristics of optical fiber: Attenuation, Material absorption losses, Linear scattering losses, Nonlinear scattering losses, Fiber bend loss, Dispersion, Chromatic dispersion, Intermodal dispersion: Multimode step index fiber. Optical Fiber Connectors: Fiber alignment and joint loss, Fiber splices, Fiber connectors, Fiber couplers.	10
III	Optical sources: LEDs and LDs, structures, characteristics, modulators using LEDs and LDs. coupling with fibres, noise in Laser diodes, Amplified Spontaneous Emission noise, effects of Laser diode noise in fibre communications Optical detectors: Types and characteristics, structure and working of PIN and AP, noise in detectors, comparison of performance. Optical receivers, Ideal photo receiver and quantum limit of detection	10
IV	Optical Amplifiers: basic concept, applications, types, doped fibre amplifiers, EDFA, basic theory, structure and working, Semiconductor laser amplifier, Raman amplifiers, TDFA, amplifier configurations, performance comparison.	8
V	The WDM concept, WDM standards, WDM components, couplers, splitters, Add/ Drop multiplexers, gratings, tunable filters. Introduction to free space optics, LiFi technology and VLC. Optical Time Domain Reflectometer (OTDR) – fault detection length and refractive index measurements	7
	Total hours	45

**vi) ASSESSMENT PATTERN****Mark distribution**

Total Marks	Continuous Internal Evaluation Marks	End Semester Evaluation Marks	End Semester Examination Duration
150	50	100	3 Hours

Continuous Internal Evaluation Pattern:

Attendance	10 Marks
Continuous Assessment Tests (2 numbers)	25 Marks
Assignment/Quiz/Course project	15 Marks

End Semester Examination Pattern:

There will be two parts; Part A and Part B. Part A contain 10 questions with 2 questions from each module, having 3 marks for each question. Students should answer all questions. Part B contains 2 questions from each module of which student should answer any one. Each question can have maximum 2 sub-divisions and carry 14 marks.



Course Code	Course Name	Category	L	T	P	Credit	Year of Introduction
EC1U41B	COMPUTER NETWORKS	PEC	3	0	0	3	2020

i) **PREREQUISITE:** MA0U20C - Probability, Random Process, and Numerical Methods

ii) **COURSE OVERVIEW**

This course aims to expose students to computer networks taking a top-down approach of viewing from the layer of user applications and zooming into link layer protocols

iii) **COURSE OUTCOMES**

After the completion of the course, the student will be able to

Course Outcomes	Description	Level
CO 1	Describe the protocols used in web and email applications.	Understand
CO 2	Explain the concept of reliable data transfer, flow control and congestion over a TCP network.	Understand
CO 3	Apply Dijkstra's algorithm and distance-vector algorithm in the context of routing over computer networks	Apply
CO 4	Explain the services provided by the link layer and addressing involved in it.	Understand
CO 5	Analyze the delay performance of an ARQ system using standard queuing models.	Apply

iv) **SYLLABUS**

Components of computer network, Applications of computer network – the Internet, Definition of protocol. Network edges, Network core and Network links- TDM versus statistical multiplexing, Datagram versus Virtual-circuit networks.- Access and physical media. Delay and loss in packet-switched networks. Application layer: Web application: HTTP, Message format, Email application: SMTP, Message format, MIME, POP3 and Web-based email. Transport Layer: UDP, Protocols for reliable data transfer: TCP Connection, segment structure, Congestion Control. Network Layer: Router architecture, -IPv4 and IPv6. Routing Algorithms- Link-State (Dijkstra's) Algorithm, Distance vector algorithm. Routing in Internet. Services of link layer, Error detection and correction. Multiple access protocols. Link layer addressing. Ethernet. IEEE 802.11 wireless LAN- Queuing models in computer networks : Little's theorem and examples. Review of Poisson process. M/G/1 Queue. Delay analysis of Go-Back-N ARQ system

v) a) **TEXT BOOKS**

1. James F. Kurose, Keith W. Ross, *Computer Networking: A Top-Down Approach Featuring the Internet*, 3rd edition, Pearson
2. D. Bertsekas, RG Gallager, *Data Networks*, Prentice Hal

**b) REFERENCES**

1. N. Abramson, F. Kuo, *Computer Communication Networks*, Prentice Hall
2. A. S. Tanenbaum, D. J. Wetherall, *Computer Networks*, Pearson
3. A. Kumar, D. Manjunath, J. Kuri, *Communication Networking – An Analytical Approach*, Morgan Kaufman Series.
4. Larry L. Peterson, Bruce S. Davie, *Computer Networks – A Systems Approach*, Morgan Kaufman

vi) COURSE PLAN

Module	Contents	No. of hours
I	<p>Components of computer networks Components of computer network, Applications of computer network – the Internet, Definition of protocol. Protocol standardization.</p> <p>Network edges, Network core and Network links Client and server hosts, connectionless and connection-oriented services provided to hosts, circuit-switched versus packet-switched network cores, FDM, TDM versus statistical multiplexing, Datagram versus Virtual-circuit networks. Access and physical media.</p> <p>Delay and loss in packet-switched networks Types of delay, Packet loss. Layered Architecture: Protocol layering, Internet protocol stack, Message encapsulation.</p> <p>Application Layer Communication between processes, Web application: HTTP, Message format, Email application: SMTP, Message format, MIME, POP3 and Web-based email. Domain Name System (DNS)</p>	12
II	<p>Transport Layer UDP, Protocols for reliable data transfer: ARQ protocols, stop-and-wait protocol, Go-backN, Selective Repeat. TCP Connection, segment structure, RTT estimate, Flow control. Congestion Control General approaches. TCP congestion control</p>	8
III	<p>Network Layer Datagram versus virtual-circuit network service, Router architecture, IPv4: datagram format, addressing, address assignment – manual and DHCP, ICMP. IPv6. Routing Algorithms Link-State (Dijkstra's) Algorithm, Distance vector algorithm. Routing in Internet – RIP, OSPF, BGP.</p>	10
IV	<p>Link Layer Services of link layer, Error detection and correction – checksum, CRC. Multiple access protocols – Channel partitioning, random access, taking-turns. CSMA, CSMA/CA, CSMA/CD. Link layer addressing: MAC address, ARP, DHCP. Ethernet.</p>	8
V	<p>Wireless Networks IEEE 802.11 wireless LAN Queueing models in computer networks Little's theorem and examples. Review of Poisson process. M/G/1 Queue. Delay analysis of Go-Back-N ARQ system</p>	7
	Total hours	45

**(vii) ASSESSMENT PATTERN****Mark distribution**

Total Marks	Continuous Internal Evaluation Marks	End Semester Evaluation Marks	End Semester Examination Duration
150	50	100	3 Hours

Continuous Internal Evaluation Pattern:

Attendance	10 Marks
Continuous Assessment Tests (2 numbers)	25 Marks
Assignment/Quiz/Course project	15 Marks

End Semester Examination Pattern:

There will be two parts; Part A and Part B. Part A contain 10 questions with 2 questions from each module, having 3 marks for each question. Students should answer all questions. Part B contains 2 questions from each module of which student should answer any one. Each question can have maximum 2 sub-divisions and carry 14 marks



Course Code	Course Name	Category	L	T	P	Credit	Year of Introduction
EC1U41C	OPTO-ELECTRONIC DEVICES	PEC	2	1	0	3	2020

i) **PREREQUISITE:** PH0U10A - Engineering Physics, EC1U20A - Solid State Devices

ii) **COURSE OVERVIEW:** This course aims to develop an insight over the working principles and performance parameters of various optoelectronics devices used for optical networks and communication.

iii) **COURSE OUTCOMES**

After the completion of the course the student will be able to:

Course Outcomes	Description	Level
CO 1	Explain the property of absorption, recombination and photoemission in semiconductors.	Understand
CO 2	Distinguish different optical sources used in optoelectronic applications.	Understand
CO 3	Analyse different types of photodetectors based on their performance parameters	Apply
CO 4	Explain various optical modulators and optoelectronic devices.	Understand
CO 5	Explain various optical devices used for optical communication.	Understand

iv) **SYLLABUS**

Fundamentals of Semiconductor Optoelectronics, Optical Sources, Optical Detectors, Optoelectronic Devices and Modulators, Optical Devices in Optoelectronic Networks.

v) a) **TEXT BOOKS**

1. Pallab Bhattacharya: Semiconductor Optoelectronic Devices, Pearson, 2009.

b) **REFERENCES**

1. Mark Csele, Fundamentals of Light Sources and Lasers, Wiley-Interscience, 2004.
2. W.Koechner,M.Bass, Solid State Lasers, Springer, 2003.
3. Yariv, Photonics Optical Electronics in modern communication, 6/e ,Oxford University Press,2006.
4. Harry J R Dutton, Understanding Optical Communications, IBM 1/e 1998.
5. Alastair Buckley, Organic Light-Emitting Diodes, Woodhead, 2013.
6. Stephen J Fonash, Solar Cell Device Physics, Elsevier 2/e, 2010.



vi) COURSE PLAN

Module	Contents	No. of hours
I	Optical processes in semiconductors: electron-hole generation and recombination, Absorption, Auger recombination, Heat generation and dissipation, Heat sources. Various light production mechanisms, Indirect band gap materials, Semiconductors used for optical Applications, Basic principle of LED and LASER, Spontaneous emission and Stimulated Emission, Coherence of sources.	9
II	Construction and Operation of LEDs, Heterojunctions, Surface Emitter and Edge Emitter LEDs, Characteristics of LEDs, LASERs, Threshold Condition for lasing, Line Broadening Mechanisms, Fabry-Perot Lasers, Distributed Feedback (DFB) Lasers, Distributed Bragg Reflector (DBR) Lasers, Vertical Cavity Surface Emitting Lasers (VCSELs), In-Fibre Lasers.	9
III	Principle of Photo Detection, Working of LDR, PN diode, PIN diode, Avalanche Photodiode (APD), Characteristics of APD, Resonant Cavity Photodetector, Photo Transistor, Quantum efficiency, Responsivity, Noise in Photodetectors, Thermal Noise, Dark Current, Shot Noise, Quantum limit of Optical Detection.	9
IV	Optoelectronic ICs, Advantages, Liquid Crystal Display, Structure, TFT display, Structure, Polymer LED, Organic LED, Optical Modulators using PN junction, Electro-Optic Modulators, Acousto-Optic Modulators, Raman-Nath Modulators, Optical switching and Logic devices, Optical Memory. Solar Cells: basic working principle, VI Characteristics, Different types of solar cells, Dye sensitized solar cells (DSSC), Perovskite Solar cells.	9
V	Introduction to optical components, Splitters and Couplers, Directional Couplers, Fiber Bragg Gratings, Multiplexers, Attenuators, Isolators, Circulators, Fixed Filters, Tunable Filters, Add Drop Multiplexers, Waveguide Grating Routers, Optical Cross Connects, Wavelength Convertors, Optical Bistable Devices.	9
	Total hours	45

**vii) ASSESSMENT PATTERN****Mark distribution**

Total Marks	Continuous Internal Evaluation Marks	End Semester Evaluation Marks	End Semester Examination Duration
150	50	100	3 Hours

Continuous Internal Evaluation Pattern:

Attendance	10 Marks
Continuous Assessment Tests (2 numbers)	25 Marks
Assignment/Quiz/Course project	15 Marks

End Semester Examination Pattern:

There will be two parts; Part A and Part B. Part A contain 10 questions with 2 questions from each module, having 3 marks for each question. Students should answer all questions. Part B contains 2 questions from each module of which student should answer any one. Each question can have maximum 2 sub-divisions and carry 14 marks



Course Code	Course Name	Category	L	T	P	Credit	Year of Introduction
EC1U41D	INSTRUMENTATION	PEC	2	1	0	3	2020

i) **PREREQUISITE:** Nil

ii) **COURSE OVERVIEW**

This course aims to introduce the basic concepts of electronic measuring instruments for measuring physical variables using transducers and to familiarize the concepts of the control systems PLC, DCS and SCADA.

iii) **COURSE OUTCOMES**

After the completion of the course, the student will be able to

Course Outcomes	Description	Level
CO 1	Interpret the basic concepts of measuring instruments, its classification, and selection criteria, static and dynamic characteristics.	Understand
CO 2	Explain the principle, construction and working of transducers for measuring physical variables.	Understand
CO 3	Explain the principle, construction and working of various electronic measuring instruments.	Understand
CO 4	Explain the hardware architecture for PLC, DCS and SCADA.	Understand
CO 5	Apply PLC programming for basic applications.	Apply

iv) **SYLLABUS**

Generalized Configurations and Functional elements of Instrumentation systems. Need for Measurement Systems, Classification of Types of Measuring instruments. Sensors and Transducers: - Need, Classification and selection criteria. Transducer: Principles of operation, construction, applications of Resistive Transducers, Inductive Transducers, and Capacitive Transducers: Active Transducers: Thermocouple, Piezo-electric transducer, Hall Effect transducer, Flow meter. Electronic Measuring Instruments Digital storage oscilloscope, Working principle and applications of waveform analyser, digital frequency meter, harmonic distortion meter, harmonic analyser, spectrum analyser and logic state analyser IEEE - 488 General Purpose Interface Bus (GPIB) Instruments with application.EMI, Grounding and Shielding
PLC, DCS and SCADA PLC Basics: General PLC Programming Procedures, Distributed Control System; hardware components of DCS; DCS software. Introduction to SCADA: overview, Architecture – Monolithic, Distributed and Networked, SCADA Protocols. PLC Programming Basic PLC Programming : Programming ON/OFF Inputs, Creating Ladder diagrams, Register Basics, PLC Timers and Counters, PLC Arithmetic functions, Number comparison functions, Data handling Functions: master control relay function and applications; jump with non-return and return; data table, register and other move functions.

**v) a) TEXT BOOKS**

1. Ernest Doebelin, Dhanesh N. Manik, 'Doebelin's Measurement Systems', McGraw Hill, 7th Edition, 2019
2. Kalsi HS, "Electronic Instrumentation," Tata McGraw Hill, Third Edition
3. John R Hackworth, Frederick D Hackworth, Jr, "Programmable Logic controllers Programming Methods and Applications", Pearson Education.

b) REFERENCES

1. Sawhney AK, "Electrical and Electronics Measurements and Instrumentation," Dhanpat Rai and Sons
2. John W Webb, Ronald A. Reis, "Programmable Logic Controllers- Principles and applications", PHI , ND, 2006

vi) COURSE PLAN

Module	Contents	No. of hours
I	Introduction to measuring instruments Generalized Configurations and Functional elements of Instrumentation systems, Need for Measurement Systems, Classification of Types of Measuring instruments. Static and Dynamic characteristics of measuring instruments. Sensors and Transducers: - Need, Classification and selection criteria.	10
II	Principles of operation, construction, theory, advantages and disadvantages, applications of Resistive Transducers: Potentiometers, strain gauges, (metallic and semi-conductor type), Resistance Thermometer, Thermistors. Inductive Transducers: LVDT (Linear variable differential transformer). Capacitive Transducers: various capacitive transducers based upon familiar equation of capacitance (capacitive microphone) Active Transducers: Thermocouple, Piezo-electric transducer, Hall Effect transducer, Flow meter	10
III	Digital storage oscilloscope, Working principle and applications of waveform analyser, digital frequency meter, harmonic distortion meter, harmonic analyser, spectrum analyser and logic state analyser.	8
IV	An Overall looks at PLCs, General PLC Programming Procedures, Devices to which PLC Inputs and Outputs are connected. Distributed Control System: Meaning and necessity of distributed control; hardware components of DCS; DCS software. Introduction to SCADA: SCADA overview, SCADA Architecture – Monolithic, Distributed and Networked, SCADA Protocols- IEC 60870-5-101, DNP-3, Profibus, Modbus	8
V	Programming ON/OFF Inputs, Creating Ladder diagrams, Register Basics, PLC Timers and Counters, PLC Arithmetic functions, Number comparison functions, Data handling Functions: Skip function and applications; master control relay function and applications; jump with non-return and return; data table, register and other move functions.	9
	Total hours	45

**(vii) ASSESSMENT PATTERN****Mark distribution**

Total Marks	Continuous Internal Evaluation Marks	End Semester Evaluation Marks	End Semester Examination Duration
150	50	100	3 Hours

Continuous Internal Evaluation Pattern:

Attendance	10 Marks
Continuous Assessment Tests (2 numbers)	25 Marks
Assignment/Quiz/Course project	15 Marks

End Semester Examination Pattern:

There will be two parts; Part A and Part B. Part A contain 10 questions with 2 questions from each module, having 3 marks for each question. Students should answer all questions. Part B contains 2 questions from each module of which student should answer any one. Each question can have maximum 2 sub-divisions and carry 14 marks



Course Code	Course Name	Category	L	T	P	Credit	Year of Introduction
EC1U41E	ERROR CONTROL CODES	PEC	2	1	0	3	2020

i) **PREREQUISITE:** EC1U30G - Information Theory and Coding

ii) **COURSE OVERVIEW:**

This course aims to give an insight into the various codes used for error control in data transmission.

iii) **COURSE OUTCOMES**

After the completion of the course, the student will be able to:

Course Outcomes	Description	Level
CO 1	Describe the principles of block codes, types and their bounds.	Understand
CO 2	Illustrate the principles of cyclic codes and Galois Fields, encoding and decoding of binary BCH codes and algorithms for finding the error location polynomial	Understand
CO 3	Demonstrate encoding, decoding and error location of Reed Solomon codes and Reed Muller codes	Apply
CO4	Illustrate the encoding and decoding of Convolution Codes and Turbo Codes	Apply
CO5	Describe the encoding, decoding and applications of LDPC Codes	Apply
CO6	Discuss the concepts of polar codes and its applications in 5G	Apply

iv) **SYLLABUS**

Error Control Coding – Relevance of error control codes in Communication System, concepts of Code rate, Hamming Distance, Minimum Distance, Error detecting and correcting capability.

Repetition Codes, Hamming Codes, Review of Groups, Fields, Vector Spaces. Linear Block Codes - Generator matrix, Parity Check Matrix. Dual Codes, Error Detection and Correction over hard output channels. Dual of binary Hamming codes. Maximum Likelihood Decoding Simple bounds on block codes - Singleton bound, Hamming Bound, Gilbert-Varshamov bound. Maximum-distance-separable (MDS) codes.

Review of basic concepts of cyclic codes – generator matrix, parity-check matrix. Polynomial view point. Encoding, systematic encoding, syndrome decoding.

Galois Fields -- Irreducible and Primitive Polynomials, Primitive elements, Field extension, Conjugate elements and Minimal Polynomials. Cyclotomic cosets.

BCH Codes - Design, BCH Bound, Decoding BCH codes – Decoding BCH – the general outline, computation of the syndrome, error locator polynomial, Chien Search algorithm, Finding the error locator polynomial. Berlekamp Massey Algorithm. Burst-error correction capability of BCH codes.



Reed Solomon Codes – BCH code viewpoint. Vandermonde matrix view point. MDS property. Generalized Reed-Solomon codes. Application of BCH decoding algorithms to Reed-Solomon decoding. Sudan's algorithm for decoding. Use of RS codes in disks and cloud storage. Reed Muller Codes, Encoding and decoding of RM (1, m) codes. Majority-logic decoding of Reed-Muller codes.

Convolution Codes, State Diagram, Systematic Encoders, Decoding of Convolution Codes – Viterbi algorithm, Turbo Codes, Encoding parallel concatenated codes.

Low Density Parity Codes, Construction, Tanner Graphs, Message passing decoding. Example of message passing decoding over binary erasure channels. Message passing of LLR and decoding over AWGN channels.

Polar Codes – Introduction, polarization of BEC channels, Polar transform and frozen bits. LDPC and Polar codes in 5G.

v) TEXT BOOKS & REFERENCES

1. Shu Lin, D. J Costello Jr. Error Control Coding: Fundamentals and Applications, Prentice Hall
2. Ron M Roth, Introduction to Coding Theory, Cambridge University Press
3. Todd K. Moon, Error Correction Coding: Mathematical Methods and Algorithms, Wiley.
4. T. Richardson, R. Urbanke, Modern Coding Theory, Cambridge University Press
5. H. Pfister, A Brief Introduction to Polar Codes, Lec. Notes
6. O. Gazi, Polar Codes: A Non-Trivial Approach to Channel Coding, Springer, 2018.
7. A. Thangaraj, LDPC and Polar Codes in 5G Standard, NPTEL Course

vi) COURSE PLAN

Module	Contents	No. of hours
I	<p>Block Codes and Bounds</p> <p>Error Control Coding – Relevance of error control codes in Communication System, concepts of Code rate, Hamming Distance, Minimum Distance, Error detecting and correcting capability.</p> <p>Repetition Codes, Hamming Codes, Review of Groups, Fields, Vector Spaces. Linear Block Codes - Generator matrix, Parity Check Matrix. Dual Codes, Error Detection and Correction over hard output channels. Dual of binary Hamming codes. Maximum Likelihood Decoding. Simple bounds on block codes - Singleton bound, Hamming Bound, Gilbert-Varshamov bound. Maximum-distance-separable (MDS) codes.</p>	9
II	<p>Cyclic Codes</p> <p>Review of basic concepts of cyclic codes – generator matrix, parity-check matrix. Polynomial view point. Encoding, systematic encoding, syndrome decoding.</p> <p>Galois Fields -- Irreducible and Primitive Polynomials, Primitive elements, Field extension, Conjugate elements and Minimal Polynomials. Cyclotomic cosets.</p> <p>BCH Codes - Design, BCH Bound, Decoding BCH codes – Decoding BCH – the general outline, computation of the syndrome, error locator</p>	9



	polynomial, Chien Search algorithm, Finding the error locator polynomial. Berlekamp Massey Algorithm. Burst-error correction. Capability of BCH codes.	
III	Reed-Solomon and Reed-Muller Codes Reed Solomon Codes – BCH code viewpoint. Vandermonde matrix view point. MDS property. Generalized Reed-Solomon codes. Application of BCH decoding algorithms to Reed-Solomon decoding. Sudan’s algorithm for decoding. Use of RS codes in disks and cloud storage. Reed Muller Codes, Encoding and decoding of RM (1, m) codes. Majority-logic decoding of Reed-Muller codes.	9
IV	Convolutional and Turbo Codes Convolution Codes, State Diagram, Systematic Encoders, Decoding of Convolution Codes – Viterbi algorithm. Turbo Codes, Encoding parallel concatenated codes.	9
V	LDPC and Polar Codes Low Density Parity Codes, Construction, Tanner Graphs, Message passing decoding. Example of message passing decoding over binary erasure channels. Message passing of LLR and decoding over AWGN channels. Polar Codes – Introduction, polarization of BEC channels, Polar transform and frozen bits. LDPC and Polar codes in 5G.	9
	Total hours	45

vi) ASSESSMENT PATTERN

Mark distribution

Total Marks	Continuous Internal Evaluation Marks	End Semester Evaluation Marks	End Semester Examination Duration
150	50	100	3 Hours

Continuous Internal Evaluation Pattern:

Attendance	10 Marks
Continuous Assessment Tests (2 numbers)	25 Marks
Assignment/Quiz/Course project	15 Marks

End Semester Examination Pattern:

There will be two parts; Part A and Part B. Part A contain 10 questions with 2 questions from each module, having 3 marks for each question. Students should answer all questions. Part B contains 2 questions from each module of which student should answer any one. Each question can have maximum 2 sub-divisions and carry 14 marks.



Course Code	Course Name	Category	L	T	P	Credit	Year of Introduction
EC1U41F	MACHINE LEARNING	PEC	2	1	0	3	2020

i) **PREREQUISITE:** MA0U10A-Linear Algebra and Calculus, MA0U20C -Probability, Random Process, and Numerical Methods

ii) **COURSE OVERVIEW:**

This course aims to impart the fundamentals of machine learning techniques.

iii) **COURSE OUTCOMES**

After the completion of the course, the student will be able to:

Course Outcomes	Description	Level
CO 1	Explain the basics of machine learning and its different types of applications.	Understand
CO 2	Differentiate regression and classification theory in machine learning.	Understand
CO 3	Apply linear algebra and statistical methods in discriminant based algorithms.	Apply
CO 4	Explain the basics of supervised and unsupervised learning algorithms and non-metric methods.	Understand
CO 5	Summarize ensemble methods, dimensionality reduction, evaluation, model selection.	Apply

iv) **SYLLABUS**

Basics of machine learning, supervised and unsupervised learning, feature extraction, over-fitting, curse of dimensionality. Review of probability theory. Regression: linear regression, Classification : Bayes' decision theory, discriminant functions and decision surfaces, classification applications, Linear discriminant based algorithm: perceptron, gradient descent method, support vector machines. Unsupervised learning: Clustering, Ensemble methods. Dimensionality reduction, Evaluation and model Selection, Confusion matrix.

v) a) **TEXT BOOKS**

Bernard Widrow and Samuel D. Stearns, —Adaptive Signal Processing, Person Bishop, C. M. "Pattern Recognition and Machine Learning" Springer, New York, 2006.
Theodoridis, S. and Koutroumbas, K. "Pattern Recognition". Academic Press, San Diego, 2003.

b) **REFERENCES**

1) Bishop, C. M. "Pattern Recognition and Machine Learning" Springer, New York, 2006.

**vi) COURSE PLAN**

Module	Contents	No. of hours
I	Basics of machine learning, supervised and unsupervised learning, examples, features, feature vector, training set, target vector, test set feature extraction, over-fitting, curse of dimensionality. Review of probability theory, Gaussian distribution, decision theory.	10
II	Regression: linear regression, error functions in regression 2 multivariate regression, regression applications, bias and variance. Classification : Bayes' decision theory, discriminant functions and decision surfaces, Bayesian classification for normal distributions, classification applications.	10
III	Linear discriminant based algorithm: perceptron, Gradient descent method, perceptron algorithm, support vector machines , SVM for separable classes and non-separable classes, multiclass case.	8
IV	Unsupervised learning: Clustering, examples, criterion functions for clustering Proximity measures, algorithms for clustering. Ensemble methods: boosting, bagging. Basics of decision trees, random forest, examples.	7
V	Dimensionality reduction: principal component analysis, Fischer's discriminant analysis. Evaluation and model selection: ROC curves, evaluation measures, validation set, bias-variance trade-off. confusion matrix, recall, precision, accuracy.	10
	Total hours	45

vii) ASSESSMENT PATTERN**Mark distribution**

Total Marks	Continuous Internal Evaluation Marks	End Semester Evaluation Marks	End Semester Examination Duration
150	50	100	3 Hours

Continuous Internal Evaluation Pattern:

Attendance	10 Marks
Continuous Assessment Tests (2 numbers)	25 Marks
Assignment/Quiz/Course project	15 Marks

End Semester Examination Pattern:

There will be two parts; Part A and Part B. Part A contain 10 questions with 2 questions from each module, having 3 marks for each question. Students should answer all questions. Part B contains 2 questions from each module of which student should answer any one. Each question can have maximum 2 sub-divisions and carry 14 marks.



Course Code	Course Name	Category	L	T	P	Credit	Year of Introduction
EC1U41G	DSP ARCHITECTURE	PEC	2	1	0	3	2020

i) **PREREQUISITE:** EC1U30B - Digital Signal processing

ii) **COURSE OVERVIEW:**

The aim of the course is to give an overview of the commonly used DSP algorithms, their applications, and various techniques for the algorithmic and architecture level optimisations through various algorithm to architecture mapping which can lead to efficient hardware implementations. The course also introduces the basic features in Digital Signal Processors, DSP architecture with case studies, the latest architectural trends in DSP and their programming tools.

iii) **COURSE OUTCOMES**

After the completion of the course, the student will be able to:

Course Outcomes	Description	Level
CO 1	Solve the basic resource constraints in a practical DSP system using various techniques/transformations that map the DSP algorithms to efficient architectures.	Understand
CO 2	Illustrate various single core and multicore Digital Signal Processor architectures and identify the optimal processor for solving real life signal processing problems.	Understand
CO 3	Develop algorithms to solve signal processing problems using the latest hardware platforms and software tools.	Apply

iv) **SYLLABUS**

Basics of DSP Algorithm Representation to Architecture Mapping - DSP Algorithm representations, Introduction to Filter structures- Recursive, Fundamentals of DSP algorithm to architecture mapping; Transformations for Improved DSP Architectures - VLSI performance measures, Transformations for improved DSP architectures, Pipelining, Folding and Unfolding Transformations and its applications; Single Core DSP Architectures - Introduction to General Purpose Processors (GPP), The key features of a Digital Signal Processors, Harvard DSP architectures, VLIW Architecture and Single Instruction Multiple Data (SIMD) processor architecture; Homogeneous Multicore DSPs - multicore processors and their applications, Multicore DSP Architectures: The TMS320C66x architecture; Programming the DSPs - Code Composer Studio (CCS) software development tool and the TMS320C6678 EVM kit, OpenMP Application Programming Interface (API) and Open Computing Language (OpenCL), Latest architectural trends in digital signal processing: Introduction to Heterogeneous Multicore DSP Architecture and FPGA SoCs

**v) a) TEXT BOOKS**

- 1) Bernard Keshab K. Parhi, "VLSI Signal Processing Systems, Design and Implementation", John Wiley & Sons, 1999
- 2) Naim Dahnoun, "Multicore DSP: from algorithms to real-time implementation on the TMS320C66x SoC". John Wiley & Sons, 2018.
- 3) Steven W. Smith, "The Scientist and Engineer's Guide to Digital Signal Processing", Second Edition, California Technical Publishing, 1999.
- 4) Reference Link for Overview of Latest Processor Architectures–Digital signal processors (DSPs) | Overview | Processors | TI.com, <https://training.ti.com/system/files/docs/c66x-corepac-instruction-set-reference-guide.pdf>

b) REFERENCES

- 1) Simon Rulph Chassaing, "Digital Signal Processing and Applications with the C6713 and C6416 DSK", John Wiley & Sons, 2005.
- 2) Sen M. Kuo, Woon-Seng S. Gan, Digital Signal Processors: Architectures, Implementations, and Applications, Prentice Hall, 2004.
- 3) Lars Wanhammar, DSP Integrated Circuits, Academic Press, 1999.
- 4) B Venkataramani, M Bhaskar, "Digital Signal Processors: Architecture, Programming and Applications", 2nd Ed., Tata McGraw-Hill Education, 2002.
- 5) A. Kharin, S. Vityazev and V. Vityazev, "Teaching multi-core DSP implementation on EVM C6678 board," 2017 25th European Signal Processing Conference (EUSIPCO), 2017, pp. 2359-2363, doi: 10.23919/EUSIPCO.2017.8081632

vi) COURSE PLAN

Module	Contents	No. of hours
I	Basics of DSP Algorithm Representation to Architecture Mapping: DSP Algorithm representations –Block Diagram, Signal Flow Graph, Data Flow Graph, Dependence Graph; Introduction to Filter structures- Recursive, Non-recursive and Lattice structures; Fundamentals of DSP algorithm to architecture mapping - Loop bound, Iteration Bound, Critical Path, Algorithms for computing Iteration Bound – Longest Path Matrix Algorithm, Minimum Cycle Mean Algorithm.	10
II	Transformations for Improved DSP Architectures: VLSI performance measures - area, power, and speed; Transformations for improved DSP architectures: Pipelining - Pipelining of FIR filters, Concept of Fine Grain Pipelining; Parallel Processing – Designing Parallel FIR systems, Pipelining and Parallel Processing for low power. Folding and Unfolding Transformations and its applications.	9
III	Single Core DSP Architectures: Introduction to General Purpose Processors (GPP), Microcontroller Units (MCU), Digital Signal Processors (DSP) – comparison and Applications. The key features of a Digital Signal Processors – Dedicated hardware units, circular buffers, Modified bus structures and Memory access schemes. Introduction to Harvard, Super Harvard DSP architectures, Concept of Instruction Level Parallelism, VLIW	9



	Architecture and Single Instruction Multiple Data (SIMD) processor architecture. Case Study: Introduction to a popular DSP from Texas Instruments, The TMS320C67xxSeries Processor - CPU Architecture - CPU Data Paths and Control - Timers -Internal Data/ Program Memory - External Memory Interface.	
IV	Homogeneous Multicore DSPs: Introduction to multicore processors and their applications, A brief comparison between DSP SoCs, Field-Programmable Gate Arrays (FPGAs), Graphic Processors and CPUs. Introduction to Multicore DSP Architectures: The TMS320C66x architecture: The CPU, Overview of the peripherals, Useful instructions, Overview of the memory organization.	8
V	Programming the DSPs: Introduction to Code Composer Studio (CCS) software development tool and the TMS320C6678 EVM kit. Introduction to OpenMP Application Programming Interface (API) and Open Computing Language (OpenCL). Implementation of simple DSP algorithms – Dot Product. Latest architectural trends in digital signal processing: Introduction to Heterogeneous Multicore DSP Architecture and FPGA SoCs.	9
	Total hours	45

vii) ASSESSMENT PATTERN**Mark distribution**

Total Marks	Continuous Internal Evaluation Marks	End Semester Evaluation Marks	End Semester Examination Duration
150	50	100	3 Hours

Continuous Internal Evaluation Pattern:

Attendance	10 Marks
Continuous Assessment Tests (2 numbers)	25 Marks
Assignment/Quiz/Course project	15 Marks

End Semester Examination Pattern:

There will be two parts; Part A and Part B. Part A contain 10 questions with 2 questions from each module, having 3 marks for each question. Students should answer all questions. Part B contains 2 questions from each module of which student should answer any one. Each question can have maximum 2 sub-divisions and carry 14 marks.



OPEN ELECTIVE

Course Code	Course Name	Category	L	T	P	Credit	Year of Introduction
EC0U41A	MECHATRONICS	OEC	2	1	0	3	2020

i) COURSE OVERVIEW

This course introduces students to the rapidly emerging, multi-disciplinary, and exciting field of Mechatronics

ii) COURSE OUTCOMES

After the completion of the course, the student will be able to:

Course Outcomes	Description	Level
CO 1	Understand the working principles of various sensors and actuators in Mechatronics systems and be able to choose the suitable one for the real world application	Understand
CO 2	Formulate and simulate models of mechatronics systems	Apply
CO 3	Explain the implementation of PLC in mechatronics applications	Understand
CO 4	Explain the standard fabrication techniques and principle of operation of MEMS devices	Understand
CO 5	Design and analyse the commonly encountered mechatronics systems for real time application	Analyze

iii) SYLLABUS

Introduction to Mechatronics: Structure of Mechatronics system. Comparison between traditional and mechatronics approach. Sensors - Characteristics -Temperature, flow, pressure sensors. Displacement, position and proximity sensing by magnetic, optical, ultrasonic, inductive, capacitive and eddy current methods. Encoders: incremental and absolute. Resolvers and synchros. Piezoelectric sensors. Acoustic Emission sensors. vibration sensors. Force and tactile sensors. Range finders: ultrasonic and light base range finders

Actuators: Hydraulic and Pneumatic actuators - Directional control valves, pressure control valves, process control valves. Rotary actuators. Development of simple hydraulic and pneumatic circuits using standard Symbols. Electrical drives: DC, AC, brushless, servo and stepper motors. Harmonic drive. Magnetostrictive actuators and piezoelectric actuators.

System modelling - Mathematical models and basic building blocks of general mechanical, electrical, fluid and thermal systems. Typical elements of open and closed loop control systems. Adaptive controllers for machine tools. Programmable Logic Controllers (PLC) – Basic structure, input/ output processing. Programming: Timers, Internal Relays, Counters and Shift registers. Development of simple ladder programs for specific purposes.

Micro Electro Mechanical Systems (MEMS): Fabrication: Deposition, Lithography, Micromachining methods for MEMS -Surface and Bulk, Deep Reactive Ion Etching (DRIE) and LIGA processes. Principle, fabrication and working of MEMS based pressure sensor, accelerometer and gyroscope.



Mechatronics in Robotics- choice of Sensors and Actuators. Robotic vision system – Image acquisition: Vidicon, charge coupled device (CCD) and charge injection device (CID) cameras. Image processing techniques: histogram processing: sliding, stretching, equalization and thresholding. Case studies of Mechatronics systems: Automatic camera, bar code reader, simple weighing machine, pick and place robot, automatic car park barrier system, automobile engine management system.

iv) (a) TEXT BOOKS

- 1) Bolton W., Mechatronics: Electronic Control Systems in Mechanical and Electrical Engineering, Person Education Limited, New Delhi, 2007
- 2) Ramachandran K. P., G. K. Vijayaraghavan, M. S. Balasundaram, Mechatronics: Integrated Mechanical Electronic Systems, Wiley India Pvt. Ltd., New Delhi, 2008.
- 3) Saeed B. Niku, Introduction to Robotics: Analysis, Systems, Applications, Person Education, Inc., New Delhi, 2006.
- 4) Devdas Shetty, Richard A. Kolk, “Mechatronics System Design”, Thomson Learning Publishing Company, Vikas publishing house, Second edition, 2001.

(b) REFERENCES

- 1) David G. Aldatore, Michael B. Histan, Introduction to Mechatronics and Measurement Systems, McGraw-Hill Inc., USA, 2003.
- 2) Gordon M. Mair, Industrial Robotics, Prentice Hall International, UK, 1998.
- 3) HMT, Mechatronics, Tata McGraw-Hill Publishing Company Ltd., New Delhi, 2004.
- 4) Vijay K. Varadan, K. J. Vinoy, S. Gopalakrishnan, Smart Material Systems and MEMS: Design and Development Methodologies, John Wiley & Sons Ltd., England, 2006.
- 5) Bishop, Robert H. The Mechatronics Handbook-2 Volume Set. CRC press, 2002.

v) COURSE PLAN

Module	Contents	No. of hours
I	Introduction to Mechatronics: Structure of Mechatronics system. Comparison between traditional and mechatronics approach. Sensors - Characteristics -Temperature, flow, pressure sensors. Displacement, position and proximity sensing by magnetic, optical, ultrasonic, inductive, capacitive and eddy current methods. Encoders: incremental and absolute. Resolvers and synchros. Piezoelectric sensors. Acoustic Emission sensors. vibration sensors. Force and tactile sensors. Range finders: ultrasonic and light base range finders	9
II	Actuators: Hydraulic and Pneumatic actuators - Directional control valves, pressure control valves, process control valves. Rotary actuators. Development of simple hydraulic and pneumatic circuits using standard Symbols. Electrical drives: DC, AC, brushless, servo and stepper motors. Harmonic drive. Magnetostrictive actuators and piezoelectric actuators.	9



III	System modelling - Mathematical models and basic building blocks of general mechanical, electrical, fluid and thermal systems. Typical elements of open and closed loop control systems. Adaptive controllers for machine tools. Programmable Logic Controllers (PLC) –Basic structure, input/ output processing. Programming: Timers, Internal Relays, Counters and Shift registers. Development of simple ladder programs for specific purposes.	9
IV	Micro Electro Mechanical Systems (MEMS): Fabrication: Deposition, Lithography, Micromachining methods for MEMS - Surface and Bulk, Deep Reactive Ion Etching (DRIE) and LIGA processes. Principle, fabrication and working of MEMS based pressure sensor, accelerometer and gyroscope.	9
V	Mechatronics in Robotics- choice of Sensors and Actuators. Robotic vision system – Image acquisition: Vidicon, charge coupled device (CCD) and charge injection device (CID) cameras. Image processing techniques: histogram processing: sliding, stretching, equalization and thresholding. Case studies of Mechatronics systems: Automatic camera, bar code reader, simple weighing machine, pick and place robot, automatic car park barrier system, automobile engine management system.	9
Total hours		45

vi) ASSESSMENT PATTERN

Mark distribution

Total Marks	Continuous Internal Evaluation Marks	End Semester Evaluation Marks	End Semester Examination Duration
150	50	100	3 Hours

Continuous Internal Evaluation Pattern:

Attendance	10 Marks
Continuous Assessment Tests (2 numbers)	25 Marks
Assignment/Quiz/Course project	15 Marks

End Semester Examination Pattern:

There will be two parts; Part A and Part B. Part A contain 10 questions with 2 questions from each module, having 3 marks for each question. Students should answer all questions. Part B contains 2 questions from each module of which student should answer any one. Each question can have maximum 2 sub-divisions and carry 14 marks.



Course Code	Course Name	Category	L	T	P	Credit	Year of Introduction
EC0U41B	BIOMEDICAL INSTRUMENTATION	OEC	3	0	0	3	2020

i) COURSE OVERVIEW

This course aims to give a brief introduction to human physiology and various instrumentations system used for measurement and analysis of physiological parameters.

ii) COURSE OUTCOMES

After the completion of the course, the student will be able to:

Course Outcomes	Description	Level
CO 1	Explain the human anatomy and physiological signal Measurements.	Understand
CO 2	Illustrate various techniques used for measurement of Blood flow, blood pressure, and respiration rate and body temperature.	Understand
CO 3	Explain the recording of ECG, EEG, EMG and ERG signals.	Understand
CO 4	Summarize the concept of assisting and therapeutic devices.	Understand
CO 5	Describe the advances in medical imaging techniques.	Understand

iii) SYLLABUS

Introduction to human physiological system

Physiological systems of the body (brief discussion on Heart and cardio vascular system, Anatomy of nervous system, Physiology of respiratory systems) problems encountered in biomedical measurements. Sources of bioelectric potentials – resting and action potentials – propagation of action potentials – bio electric potentials example (ECG, EEG, EMG, ERG, EOG, EGG etc.)

Bio potential electrodes and ECG

Bio potential electrodes – theory – microelectrodes – skin surface electrodes – needle electrodes – biochemical transducers –transducers for biomedical applications. Instrumentation for clinical laboratory: Bio Potential amplifiers instrumentation amplifiers, isolation amplifiers, chopper amplifier Electro conduction system of the heart. Electro cardiograph –electrodes and leads – Einthoven triangle, ECG read out devices, ECG machine – block diagram.

Measurement of blood pressure, blood flow and heart sound

Measurement of blood pressure – direct and indirect measurement– oscillometric measurement – ultrasonic method, measurement of blood flow and cardiac output, plethysmography –photo electric and impedance plethysmographs. Measurement of heart sounds –phonocardiography.

Measurement of EEG, EMG and Respiratory Parameters

Electro encephalogram –neuronal communication – EEG measurement, recording and analysis. Muscle response– Electromyogram (EMG) – Nerve Conduction velocity measurements- Electromyogram Measurements. Respiratory parameters – Spiro meter, pneumograph.

**Therapeutic Aid**

Cardiac pacemakers – internal and external pacemakers, defibrillators. Ventilators, heart lung machine, haemodialysis, lithotripsy, infant incubators

Advances in Radiological Imaging

X-rays- principles of generation, uses of X-rays- diagnostic still picture, fluoroscopy, angiography, endoscopy, and diathermy. Basic principle of computed tomography, magnetic resonance imaging system and nuclear medicine system – radiation therapy. Ultrasonic imaging system – introduction and basic principle.

Electrical safety

Electrical safety– physiological effects of electric current –shock hazards from electrical equipment –method of accident prevention, introduction to tele-medicine

iv) (a) TEXT BOOKS

- 1) J. G. Webster, Medical Instrumentation, Application and Design, John Wiley and Sons
- 2) L. Cromwell, F. J. Weibell and L. A. Pfeiffer, Biomedical Instrumentation Measurements, Pearson education, Delhi, 1990.
- 3) R. S. Khandpur, Handbook of Biomedical Instrumentation, Tata Mc Graw Hill.
- 4) J. J. Carr and J. M. Brown, Introduction to Biomedical Equipment Technology, Pearson Education.

(b) REFERENCES

- 1) John Enderele , Susan Blanchard, Joseph Bronzino, Introduction to Biomedical Engg, Academic Press
- 2) Welkowitz, Biomedical Instruments, Theory and Design, Elsevier
- 3) Jerry L Prince, Jonathan M Links, Medical Imaging Signals & Systems, Pearson Education

v) COURSE PLAN

Module	Contents	No. of hours
I	Introduction to human physiological system Physiological systems of the body (brief discussion on Heart and cardio vascular system, Anatomy of nervous system, Physiology of respiratory systems) problems encountered in biomedical measurements. Sources of bioelectric potentials – resting and action potentials -propagation of action potentials – bio electric potentials example (ECG, EEG, EMG, ERG, EOG, EGG etc.)	9
II	Bio potential electrodes and ECG Bio potential electrodes – theory – microelectrodes – skin surface electrodes – needle electrodes – biochemical transducers – transducers for biomedical applications. Instrumentation for clinical laboratory: Bio Potential amplifiers instrumentation amplifiers, isolation amplifiers, chopper amplifier Electro conduction system of	9



	the heart. Electro cardiograph –electrodes and leads – Einthoven triangle, ECG read out devices, ECG machine – block diagram.	
III	Measurement of blood pressure, blood flow and heart sound Measurement of blood pressure – direct and indirect measurement– oscillometric measurement – ultrasonic method, measurement of blood flow and cardiac output, plethysmography –photo electric and impedance plethysmographs. Measurement of heart sounds – phonocardiography.	9
IV	Measurement of EEG, EMG and Respiratory Parameters Electro encephalogram –neuronal communication – EEG measurement, recording and analysis. Muscle response– Electromyogram (EMG) – Nerve Conduction velocity measurements- Electromyogram Measurements. Respiratory parameters – Spiro meter, pneumograph. Therapeutic Aid Cardiac pacemakers – internal and external pacemakers, defibrillators. Ventilators, heart lung machine, haemodialysis, lithotripsy, infant incubators	9
V	Advances in Radiological Imaging X-rays- principles of generation, uses of X-rays- diagnostic still picture, fluoroscopy, angiography, endoscopy, and diathermy. Basic principle of computed tomography, magnetic resonance imaging system and nuclear medicine system – radiation therapy. Ultrasonic imaging system – introduction and basic principle. Electrical safety Electrical safety– physiological effects of electric current –shock hazards from electrical equipment –method of accident prevention, introduction to tele-medicine	9
	Total hours	45

vi) ASSESSMENT PATTERN

Mark distribution

Total Marks	Continuous Internal Evaluation Marks	End Semester Evaluation Marks	End Semester Examination Duration
150	50	100	3 Hours

Continuous Internal Evaluation Pattern:

Attendance	10 Marks
Continuous Assessment Tests (2 numbers)	25 Marks
Assignment/Quiz/Course project	15 Marks

End Semester Examination Pattern:

There will be two parts; Part A and Part B. Part A contain 10 questions with 2 questions from each module, having 3 marks for each question. Students should answer all questions. Part B contains 2 questions from each module of which student should answer any one. Each question can have maximum 2 sub-divisions and carry 14 marks.



Course Code	Course Name	Category	L	T	P	Credit	Year of Introduction
EC0U41C	ELECTRONIC HARDWARE FOR ENGINEERS	OEC	3	0	0	3	2020

i) **PREREQUISITE:** NIL

ii) **COURSE OVERVIEW**

This course will introduce students the exciting field of electronic hardware designing and prototyping. This will help students to innovate faster with electronics technology.

iii) **COURSE OUTCOMES**

After the completion of the course, the student will be able to

Course Outcomes	Description	Level
CO 1	Identify various electronic components along with their specifications.	Understand
CO 2	Design PCB using modern software tools.	Apply
CO 3	Explain various testing procedures of electronic products.	Understand
CO 4	Experiment and debug various software and hardware issues of a PC.	Apply

iv) **SYLLABUS**

Types of Components, Component Package Types, Introduction & Brief History, Introduction to Electronic Design Automation (EDA), Introduction to PCB Design using OrCAD tool, Introduction to PCB Design using PROTEUS tool, Types of Product Testing, Quality Standards, Testing Procedures, Safety Testing of Household Appliances, Testing of Electric Iron/Electric Kettle, Assembly and Maintenance of PC, Installation, Assembly and dismantling.

v) a) **TEXT BOOKS**

- 1) C. Robertson. PCB Designer's Reference. Prentice Hall, 2003.
- 2) D. Brooks, Signal Integrity Issues and Printed Circuit Board Design, Prentice Hall, 2003.
- 3) Advances in Electronic Testing, edited by D Gizopoulos, 2006

b) **REFERENCES**

- 1) C. Coombs, Printed Circuits Handbook, McGraw-Hill Professional, 6 edition, 2007.
- 2) Electronic Testing Handbook, McGraw-Hill, Dec 1993
- 3) PC Repair and Maintenance, A Practical Guide, Joel Rosenthal, Kevin Irwin, 2003
- 4) A Simple Guide to Computer Maintenance and Troubleshooting, AdaneNegaTarekegn, Alemu KumilachewTegegne, 2015



vi) COURSE PLAN

Module	Contents	No. of hours
I	Types of Components: - Active Components: Diode, Transistor, MOSFET, LED, SCR, Integrated Circuits (ICs) Passive Components: Resistor, Capacitor, Inductor, Transformer, Speaker/Buzzer. Component Package Types: - Axial lead, Radial Lead, Single Inline Package(SIP), Dual Inline Package (DIP), Transistor Outline (TO), Pin Grid Array (PGA), Metal Electrode Face (MELF), Leadless Chip Carrier (LCC), Small Outline Integrated Circuit (SOIC), Quad Flat Pack(QFP) and Thin QFP(TQFP), Ball Grid Array (BGA), Plastic Leaded Chip Carrier (PLCC). Introduction & Brief History: - What is PCB, Difference between PWB and PCB, Types of PCBs: Single Sided (Single Layer), Multi-Layer (Double Layer), PCB Materials.	9
II	Introduction to Electronic Design Automation (EDA): - Brief History of EDA, Latest Trends in Market, How it helps and why it requires, Different EDA tools, Introduction to SPICE and PSPICE Environment, Introduction and Working of PROTEUS. Introduction to PCB Design using OrCAD tool: - PCB Designing Flow Chart: Schematic Entry, Net listing, PCB Layout Designing, Prototype Designing, Design Rule Check(DRC), Design For Manufacturing(DFM) PCB Making: Printing, Etching, Drilling, Assembly of components Introduction to PCB Design using PROTEUS tool: - Assembly of simple circuits	10
III	Types of Product Testing: - Acceptance Testing, Type Testing, Safety Testing, Safety, safety standards, safety certificates (CE, UL and VDE), Effect of environmental testing(refer to IEC 60068-1 for guidance). Quality Standards: - General awareness of quality standards, quality management systems & documentation, Awareness on ISO 17025, ISO 9001, Calibration and Uncertainty of measurements, Awareness on disposal of Electronic waste	7
IV	Testing Procedures: - Switch Mode Power Supply - (Applicable Standard: IS 14886) Safety Testing(Earth Leakage current Test, Dielectric Test, Short Circuit Protection), Performance Testing (Line Regulation, Load Regulation for a variation of Load Min to Max load and vice versa) Inverter, UPS - Inverter (Applicable Standard: IS 13314) Visual Inspection, High Voltage Test, Insulation Resistance Test, No Load Test, Output Test. UPS (Applicable Standard: IEC 62040-3) Steady State Input Voltage Tolerance, Output-Normal Mode – No Load, Full Load, Overload, Short Circuit. Safety Testing of Household Appliances: - (Applicable Standard IS 302-1) Definitions and Terminology, Protection against Shock, Power Input and Current, Leakage Current and Electric Strength at Operating Temperature Testing of Electric Iron/Electric Kettle: - (Applicable Standard: IS 302-2) Ground bond resistance, Touch Current, Temperature (Thermostatic Cut off) Power Consumption.	8



V	Assembly and Maintenance of PC: - Introduction to Computer - Difference between Hardware & Software, Booting concept, Different input and output devices/ cables, connectors, different types of motherboard, controller cards, Ethernet cards, Different types of RAM used in PC's. Installation: - BIOS setting, Formatting of Hard Disk, Installation of Windows, Off-line drive installation / online drive installation / Windows file repairing / BIOS password break / Administrative password break / Data recovery. Application Software Installation, Dual Booting Installation. Assembly and dismantling:- Assembly and dismantling of PCs front panel connection, servicing of computer, Type of Backup, Taking Backup files and fine tuning the system, running diagnostics tool, running of virus protection program.	11
	Total hours	45

vii) ASSESSMENT PATTERN**Mark distribution**

Total Marks	Continuous Internal Evaluation Marks	End Semester Evaluation Marks	End Semester Examination Duration
150	50	100	3 Hours

Continuous Internal Evaluation Pattern:

Attendance	10 Marks
Continuous Assessment Tests (2 numbers)	25 Marks
Assignment/Quiz/Course project	15 Marks

End Semester Examination Pattern:

There will be two parts; Part A and Part B. Part A contain 10 questions with 2 questions from each module, having 3 marks for each question. Students should answer all questions. Part B contains 2 questions from each module of which student should answer any one. Each question can have maximum 2 sub-divisions and carry 14 marks.



Course Code	Course Name	Category	L	T	P	Credit	Year of Introduction
EC0U41D	IOT AND APPLICATIONS	OEC	2	1	0	3	2020

i) **PREREQUISITE:** Students should have a basic knowledge in Embedded systems.

ii) **COURSE OVERVIEW**

This course aims to develop skills in IoT system development and to apply the same in real life applications

iii) **COURSE OUTCOMES**

After the completion of the course the student will be able to:

Course Outcomes	Description	Level
CO 1	Understand the IoT fundamentals and architecture modeling	Understand
CO 2	Understand the smart things in IoT and functional blocks	Understand
CO 3	To understand the communication networks and protocols used in IoT.	Understand
CO 4	To understand the cloud resources, data analysis and applications.	Apply
CO 5	To apply the IoT processes in embedded applications.	Apply

iv) **SYLLABUS**

Introduction to IoT- Definitions and Characteristics, Architectural View, Logical Design of IoT- Functional blocks, Communication models, IoT Levels & Deployment Templates.

IoT and M2M- M2M, Difference between IoT and M2M, SDN and NFV for IoT, Smart Objects: Sensors, Actuators, and Smart Objects, Wireless Sensor Networks, Communication Protocols for Wireless Sensor Networks- Connecting Smart Objects

Unified Data Standards –Protocols –IEEE 802.15.4 -The Physical Layer, The Media-Access Control Layer, Uses of 802.15.4, Modbus, ZigBee-Zigbee Architecture- LoRaWAN - Standardization and Alliances, Physical Layer, MAC Layer, Topology, LTE-M, NB-IoT-Network layer. IP-based protocols -6LoWPAN and RPL

Data Collection, storage and computing Using a Cloud Platform-Introduction, Cloud Computing Paradigm for Data Collection, Storage and Computing, Cloud Deployment Models, Cloud based platforms. IoT Physical Devices & Endpoints-IoT Device –Raspberry-Pi -Board-Linux on Raspberry-Pi-Raspberry-Pi Interfaces. Raspberry Pi interfacing and Programming.

IoT privacy, security and vulnerabilities solutions, vulnerabilities, security requirements, threat analysis, security tomography, layered attacker model, Identity management. Smart and Connected Cities-An IoT Strategy for Smarter Cities, Smart City Security Architecture - Smart City Use-Case Examples

**v) (a) TEXT BOOKS**

1. Vijay Madiseti and ArshdeepBahga, “Internet of Things (A Hands-on- Approach)”, 1st Edition, VPT, 2014 (Module1,2,4)
2. David Hanes, Gonzalo Salgueiro, Patrick Grossetete, Rob Barton and Jerome Henry, IoT Fundamentals: Networking Technologies, Protocols and Use Cases for Internet of Things, Cisco Press, 2017. (Module2,3,5)
3. Rajkamal, “Internet of Things: Architecture and Design Principles”, McGraw Hill (India) Private Limited.
4. Raspberry Pi Cookbook, Software and Hardware Problems and solutions, Simon Monk, O'Reilly (SPD), 2016, ISBN.

(b) REFERENCES

1. Olivier Hersent, David Boswarthick, Omar Elloumi, “The Internet of Things –Key applications and Protocols”, Wiley, 2012 (Module 3)
2. Al-Fuqaha et al. Internet of things: A survey on enabling technologies, protocols, and applications. IEEE Communications Surveys & Tutorials (2015), pp. 2347- 2376.
3. The Internet of Things (The MIT Press Essential Knowledge series) Paperback – March 20, 2015 by Samuel Greengard
4. The Internet of Things: Converging Technologies for Smart Environments and Integrated Ecosystems, Ovidu Vermesan and Peter Friess, River Publishers.
5. Internet of Things - From Research and Innovation to Market Deployment-RIVER PUBLISHERS, PETER FRIESS, OVIDIU VERMESAN (Editors)
6. Internet of Things Security and Data Protection, Sébastien Ziegler, Springer International Publishing 2019.

vi) COURSE PLAN

Module	Contents	No. of hours
I	Introduction to IoT technology: Definitions and Characteristics of IoT, IoT Architectural View, Physical Design of IOT, Logical Design of IoT- IoT Functional blocks, IoT communication models, IoT Enabling Technologies, IoT Levels & Deployment Templates.	7
II	IoT and M2M- M2M, Difference between IoT and M2M, SDN and NFV for IoT, Smart Objects: The “Things” in IoT: Sensors, Actuators, and Smart Objects, Sensor Networks- Wireless Sensor Networks (WSNs), Communication Protocols for Wireless Sensor Networks- Connecting Smart Objects- Communication Criteria.	7
III	Unified Data Standards –Protocols –IEEE 802.15.4 -The Physical Layer, The Media-Access Control Layer, Uses of 802.15.4 ,The Future of 802.15.4: 802.15.4e and 802.15.4g–Modbus– ZigBee-Zigbee Architecture- LoRaWAN -Standardization and Alliances, Physical Layer, MAC Layer, Topology, LTE-M, NB-IoT-Network layer –The next generation: IP-based protocols - 6LoWPAN and RPL, Overview of the 6LoWPAN Adaptation Layer.	7
IV	Data Collection, storage and computing Using a Cloud Platform-Introduction, Cloud Computing Paradigm for Data Collection, Storage and Computing-Cloud Computing Paradigm, Cloud Deployment Models-Everything as a Service and Cloud Service Models-SaaS,	9



	<p>PaaS, IaaS, DaaS. Cloud based platforms-XIVELY, NIMBITS.</p> <p>IoT Physical Devices & Endpoints-IoT Device-Building blocks – Raspberry-Pi -Board-Linux on Raspberry-Pi-Raspberry-Pi Interfaces (serial, SPI, I2C). Raspberry Pi interfacing and programming examples using python (LED, switch, sensor, serial, SPI, I2C devices).</p> <p>Controlling GPIO outputs and displaying sensor readings using web interface/cloud. (Python programming is required only for assignments and projects and not for examinations. Other end nodes and platforms can also be used).</p>	
V	<p>IoT privacy, security and vulnerabilities solutions, vulnerabilities, security requirements, threat analysis, security tomography, layered attacker model, Identity management, access control, secure message communication.</p> <p>Smart and Connected Cities-An IoT Strategy for Smarter Cities-Vertical IoT Needs for Smarter Cities, Global vs. Siloed Strategies-Smart City IoT Architecture-Street Layer, City Layer, Data Center Layer, Services Layer- Smart City Security Architecture.</p> <p>Smart City Use-Case Examples – Street lighting, smart parking, smart traffic and air pollution monitoring</p>	6
	Total hours	36

vii) ASSESSMENT PATTERN

Mark distribution

Total Marks	Continuous Internal Evaluation Marks	End Semester Evaluation Marks	End Semester Examination Duration
150	50	100	3 Hours

Continuous Internal Evaluation Pattern:

Attendance	10 Marks
Continuous Assessment Tests (2 numbers)	25 Marks
Assignment/Quiz/Course project	15 Marks

End Semester Examination Pattern:

There will be two parts; Part A and Part B. Part A contain 10 questions with 2 questions from each module, having 3 marks for each question. Students should answer all questions. Part B contains 2 questions from each module of which student should answer any one. Each question can have maximum 2 sub-divisions and carry 14 marks.



Course Code	Course Name	Category	L	T	P	Credit	Year of Introduction
EC0U41E	ENTERTAINMENT ELECTRONICS	OEC	2	1	0	3	2020

i) COURSE OVERVIEW

This course introduces students to various industry standards, algorithms and technologies used to carry out digital audio and video broadcasting in the infotainment industry.

ii) COURSE OUTCOMES

After the completion of the course, the student will be able to:

Course Outcomes	Description	Level
CO 1	Describe packetized streaming of digital media	Understand
CO 2	Discuss the critical aspects of DVB and DAB standards used for media broadcasting	Understand
CO 3	Realize video coding/compression algorithms to produce high-definition video in MPEG-4 standard	Apply
CO 4	Discuss the use of modern display technologies for video reproduction	Understand

iii) SYLLABUS

Brief Review of Analog Television: Scanning, Horizontal and Vertical Synchronization, Color information, Transmission methods. NTSC and PAL standards. Digital media streaming: Packetized elementary stream of audio- video data, MPEG data stream, MPEG-2 transport stream packet, Accessing a program, scrambled programs, program synchronization. PSI, Additional (Network information and service description) information in data streams for set-top boxes.

Digital Video Broadcasting (DVB): Satellite TV broadcasting – DVB-S Parameters, DVB-S Modulator, DVB-S set-top box, DVB-S2. Cable TV broadcasting – DVB-C Standard, DVB-C Modulator, DVB- C set-top box. Terrestrial TV broadcasting – DVB-T Standard, DVB-T Modulator, DVB-T Carriers and System Parameters, DVB-T receiver. Broadcasting for Handheld devices – DVB-H Standard. DVB tele-text, DVB subtitling system.

Digital Audio Broadcasting (DAB): Comparison of DAB with DVB. Physical layer of DAB. DAB Modulator, DAB Data Structure, DAB single frequency networks, Data broadcasting using DAB.

Digital Radio Mondiale (DRM): Transmitter and receiver, Data rates.



High Definition Video and Audio: Pixel resolution, Comparison with Standard Definition TV, Review of Discrete Cosine Transforms (DCT), Video Compression - Quantization levels, Horizontal/Vertical blanking interval, Vertical Color resolution, DPCM of moving pictures, DCT, Run-length coding. MPEG-4 Video coding. Psycho-acoustic model, Principle of audio coding, Sub-band coding in MPEG layer 1 and 2, MPEG Layer 3 and Dolby Digital, Multichannel sound.

Display Technology: Block diagram of video reproduction system in a TV, Cathode Ray tubes, Basic principle of Plasma displays, LC displays, Light-emitting diode displays, Field emission displays, Organic light emitting device displays. Television of future: Holographic TV, Virtual Reality, Augmented Reality.

iv) a) TEXT BOOKS

- 1) W. Fischer, Digital Video and Audio Broadcasting Technology: A Practical Engineering Guide (Signals and Communication Technology), Springer, 2020
- 2) Lars-Ingemar Lundström, Understanding Digital Television: An Introduction to DVB Systems with Satellite, Cable, Broadband and Terrestrial TV, Focal Press, Elsevier, 2006.
- 3) K F Ibrahim, Newnes Guide to Televeision and Video Technology, Newnes, 2007.
- 4) Jiun-Haw Lee, David N. Liu, Shin-Tson Wu, Introduction to Flat Panel Displays, Wiley, 2008.

b) REFERENCES

- 1) C. Poynton, "Digital Video and HD Algorithms and Interfaces,"Morgan Kaufmann, 2012.
- 2) Wolfgang Hoeg, Thomas Lauterbach, Digital audio broadcasting: principles and applications of DAB, DAB+ and DMB, Wiley, 2009.
- 3) John Watkinson, Introduction to Digital Audio, Focal Press, 1994.
- 4) John Watkinson, Art of Digital Video, Focal Press, 2008.
- 5) John Watkinson, Introduction to Digital Video, Focal Press, 2001.

v) COURSE PLAN

Module	Contents	No. of hours
I	Analog Television, Scanning, Horizontal and Vertical Synchronization, Colour information, NTSC and PAL standards. Analog TV Transmission Packetized elementary stream. MPEG data stream, MPEG-2 transport stream packet. Accessing a program, scrambled programs, program synchronization. Program Specific Information. Additional (Network information and service description) information in data streams	9
II	Introduction to DVB, DVB-S Parameters, DVB-S Modulator, DVB-S set-top box, DVB-S2. DVB-C Standard, DVB-C Modulator, DVB-C set-top box. DVB-T Standard, DVB-T Modulator, DVB-T Carriers and System Parameters, DVB-T receiver. Broadcasting for Handheld devices – DVB-H Standard. DVB teletext, DVB subtitling system.	9



III	Introduction to DAB, Comparison of DAB with DVB. Physical layer of DAB. DAB Modulator, DAB Data Structure, DAB single frequency networks, Data broadcasting using DAB. Digital Radio Mondiale (DRM): Transmitter and receiver, Data rates.	8
IV	HDTV versus SDTV, Pixel resolution, Review of Discrete Cosine Transforms (DCT) Video Compression - Quantization levels, Horizontal/Vertical blanking interval, Vertical Colour resolution, DPCM of moving pictures, DCT, Run-length and Huffman coding. MPEG-4. Psychoacoustic model, Principle of audio coding. Subband coding in MPEG layer 1 and 2. MPEG Layer 3 and Dolby Digital, Multichannel sound	10
V	Block diagram of video reproduction system in a TV Cathode Ray tubes, Basic principle of Plasma displays, LC displays, Light-emitting diode displays, Field emission displays, Organic light emitting device displays. Holographic TV, Virtual Reality, Augmented Reality.	9
	Total hours	45

vi) ASSESSMENT PATTERN**Mark distribution**

Total Marks	Continuous Internal Evaluation Marks	End Semester Evaluation Marks	End Semester Examination Duration
150	50	100	3 Hours

Continuous Internal Evaluation Pattern:

Attendance	10 Marks
Continuous Assessment Tests (2 numbers)	25 Marks
Assignment/Quiz/Course project/Simulation Assignment	15 Marks



Simulation Assignments (optional)

1. Realise live streaming of audio and video data using Python/MATLAB-Simulink or other platforms.
2. Realise a basic video compression scheme from basic principles studied from this course using Python/MATLAB. Obtain the performance parameters before and after comparison.
3. Simulate a DAB transmitter and receiver system using MATLAB/Simulink and study its performance under Gaussian noise.

End Semester Examination Pattern:

There will be two parts; Part A and Part B. Part A contain 10 questions with 2 questions from each module, having 3 marks for each question. Students should answer all questions. Part B contains 2 questions from each module of which student should answer any one. Each question can have maximum 2 sub-divisions and carry 14 marks.



Course Code	Course Name	Category	L	T	P	Credit	Year of Introduction
EC1U49A	SEMINAR	PWS	0	0	3	2	2020

i) **PREREQUISITE:** Nil

ii) COURSE OVERVIEW

The course 'Seminar' is intended to enable a B.Tech graduate to read, understand, present and prepare report about an academic document. The learner shall search in the literature including peer reviewed journals, conference, books, project reports etc., and identify an appropriate paper/thesis/report in her/his area of interest, in consultation with her/his seminar guide. This course can help the learner to experience how a presentation can be made about a selected academic document and also empower her/him to prepare a technical report

iii) COURSE OUTCOMES

After the completion of the course the student will be able to:

Course Outcomes	Description	Level
CO 1	Identify academic documents from the literature which are related to her/his areas of interest	Apply
CO 2	Read and apprehend an academic document from the literature which is related to her/ his areas of interest	Analyze
CO 3	Prepare a presentation about an academic document (Cognitive knowledge level)	Create
CO 4	Give a presentation about an academic document	Apply
CO 5	Prepare a technical report	Create

IV) GENERAL GUIDELINES

- The Department shall form an Internal Evaluation Committee (IEC) for the seminar with academic coordinator for that program as the Chairperson/Chairman and seminar coordinator & seminar guide as members.
- During the seminar presentation of a student, all members of IEC shall be present.
- Formation of IEC and guide allotment shall be completed within a week after the University examination (or last working day) of the previous semester.
- Guide shall provide required input to their students regarding the selection of topic/ paper.
- Choosing a seminar topic: The topic for a UG seminar should be current and broad based rather than a very specific research work. It's advisable to choose a topic for the Seminar to be closely linked to the final year project area. Every member of the project team could choose or be assigned Seminar topics that covers various aspects linked to the Project area.
- A topic/paper relevant to the discipline shall be selected by the student during the semester break
- Topic/Paper shall be finalized in the first week of the semester and shall be submitted to the IEC.
- The IEC shall approve the selected topic/paper by the second week of the semester.
- Accurate references from genuine peer reviewed published material to be given in the report and to be verified



V) EVALUATION PATTERN

Total marks: 100, only CIE, minimum required to pass 50

Seminar Guide: 20 marks (Background Knowledge – 10 (The guide shall give deserving marks for a candidate based on the candidate's background knowledge about the topic selected), Relevance of the paper/topic selected – 10).

Seminar Coordinator: 20 marks (Seminar Diary – 10 (Each student shall maintain a seminar diary and the guide shall monitor the progress of the seminar work on a weekly basis and shall approve the entries in the seminar diary during the weekly meeting with the student), Attendance – 10).

Presentation: 40 marks to be awarded by the IEC (Clarity of presentation – 10, Interactions – 10 (to be based on the candidate's ability to answer questions during the interactive session of her/his presentation), Overall participation – 10 (to be given based on her/his involvement during interactive sessions of presentations by other students), Quality of the slides – 10).

Report: 20 marks to be awarded by the IEC (check for technical content, overall quality, templates followed, adequacy of references etc.).



Course Code	Course Name	Category	L	T	P	Credit	Year of Introduction
EC1U49B	PROJECT PHASE I	PWS	0	0	6	2	2020

i) **PREAMBLE:** The course ‘Project Work’ is mainly intended to evoke the innovation and invention skills in a student. The course will provide an opportunity to synthesize and apply the knowledge and analytical skills learned, to be developed as a prototype or simulation. The project extends to 2 semesters and will be evaluated in the 7th and 8th semester separately, based on the achieved objectives. One third of the project credits shall be completed in 7th semester and two third in 8th semester. It is recommended that the projects may be finalized in the thrust areas of the respective engineering stream or as interdisciplinary projects. Importance should be given to address societal problems and developing indigenous technologies

ii) COURSE OVERVIEW:

The aim of this course is to apply engineering knowledge in solving practical problems, to foster innovation in design of products, processes or systems, and to develop creative thinking in finding viable solutions to engineering problems.

iii) COURSE OUTCOMES

After the completion of the course, the student will be able to:

Course Outcomes	Description	Level
CO 1	Model and solve real world problems by applying knowledge across domains	Apply
CO 2	Develop products, processes or technologies for sustainable and socially relevant applications	Apply
CO 3	Function effectively as an individual and as a leader in diverse teams and to comprehend and execute designated tasks	Apply
CO 4	Plan and execute tasks utilizing available resources within timelines, following ethical and professional norms	Apply
CO 5	Identify technology/research gaps and propose innovative/creative solutions	Analyse
CO 6	Organize and communicate technical and scientific findings effectively in written and oral forms	Apply

Phase 1 Target

- Literature study/survey of published literature on the assigned topic
- Formulation of objectives
- Formulation of hypothesis/ design/ methodology
- Formulation of work plan and task allocation.
- Block level design documentation
- Seeking project funds from various agencies



- Preliminary Analysis/Modeling/Simulation/Experiment/Design/Feasibility study
- Preparation of Phase 1 report

Evaluation Guidelines & Rubrics

Total: 100 marks (Minimum required to pass: 50 marks).

- Project progress evaluation by guide: 30 Marks.
- Interim evaluation by the Evaluation Committee: 20 Marks.
- Final Evaluation by the Evaluation Committee: 30 Marks.
- Project Phase - I Report (By Evaluation Committee): 20Marks.

(The evaluation committee comprises HoD or a senior faculty member, Project coordinator and project supervisor).



MINORS



Course Code	Course Name	Category	L	T	P	Credit	Year of Introduction
ECOM 49A	MINI PROJECT	VAC	0	1	6	4	2020

i) COURSE OVERVIEW

The course aims

To estimate the ability of the students in transforming the theoretical knowledge studied in to a working model of an electronic system

For enabling the students to gain experience in organisation and implementation of small projects.

Design and development of Small electronic project based on hardware or a combination of hardware and software for electronics systems.

ii) COURSE OUTCOMES

After the completion of the course, the student will be able to:

Course Outcomes	Description	Level
CO 1	Practice acquired knowledge within the selected area of technology for project development.	Apply
CO 2	Identify, discuss and justify the technical aspects and design aspects of the project with a systematic approach.	Apply
CO 3	Reproduce, improve and refine technical aspects for engineering projects.	Apply
CO 4	Work as a team in development of technical projects.	Apply
CO 5	Communicate and report effectively project related activities and findings.	Apply

iii) COURSE PLAN

In this course, each group consisting of three/four members is expected to design and develop a moderately complex electronic system with practical applications, this should be a working model. The basic concept of product design may be taken into consideration.

Students should identify a topic of interest in consultation with Faculty/Advisor. Review the literature and gather information pertaining to the chosen topic. State the objectives and develop a methodology to achieve the objectives. Carryout the design/fabrication or develop codes/programs to achieve the objectives. Demonstrate the novelty of the project through the results and outputs. The progress of the mini project is evaluated based on a minimum of two reviews.

The review committee may be constituted by the Head of the Department. A project report is required at the end of the semester. The product has to be demonstrated for its full design



specifications. Innovative design concepts, reliability considerations, aesthetics/ergonomic aspects taken care of in the project shall be given due weight.

vi) ASSESSMENT PATTERN

Mark distribution

Total Marks	Continuous Internal Evaluation Marks	End Semester Evaluation Marks	End Semester Examination Duration
150	75	75	1 Hours

Evaluation

The internal evaluation will be made based on the product, the report and a viva- voce examination, conducted by a 3-member committee appointed by Head of the Department comprising HoD or a senior faculty member, Academic coordinator for that program, project guide/coordinator.

The Committee will be evaluating the level of completion and demonstration of functionality/specifications, presentation, oral examination, work knowledge and involvement.

Split-up of CIE

Component	Marks
Attendance	10
Marks awarded based on guide's evaluation	15
Project Report	10
Evaluation by Committee	40

Split-up of ESE

Component	Marks
Level of completion	10
Demonstration of functionality	25
Project Report	10
Viva-voce	20
Presentation	10



HONOURS



Course Code	Course Name	Category	L	T	P	Credit	Year of Introduction
EC1H40A	RF MEMS	VAC	4	0	0	4	2020

i) **PREREQUISITE:** Nil

ii) **COURSE OVERVIEW**

This course introduces students to the rapidly emerging, area of MEMS with special emphasis on its applications in RF and wireless engineering

iii) **COURSE OUTCOMES**

After the completion of the course, the student will be able to:

Course Outcomes	Description	Level
CO 1	Describe the various fabrication techniques and actuation mechanisms used in RF MEMS design	Understand
CO 2	Explain the principle of operation of MEMS switches	Understand
CO 3	Explain the construction and operation of micromachined passive elements	Understand
CO 4	Describe the construction and operation of micromachined passive filters, phase shifters and antenna	Understand
CO 5	Discuss the various levels and constraints in MEMS packaging	Understand

iv) **SYLLABUS**

RF MEMS for wireless applications, MEMS technology and fabrication, mechanical modeling of MEMS devices, MEMS materials and fabrication techniques surface micromachining, Bulk micromachining, LIGA, Actuation Mechanisms in MEMS, Piezoelectric, Electrostatic, Thermal, Magnetic. Capacitive shunt and series switches: Physical description, circuit model and electromagnetic modeling; Techniques of MEMS switch fabrication and packaging; Design of MEMS switches Micromachined passive elements - micromachined inductors: Effect of inductor layout, reduction of stray capacitance of planar inductors, folded inductors, variable inductors and polymer-based inductors; MEMS Capacitors: Gap-tuning and area tuning capacitors, dielectric tunable capacitors. Principle of operation of micromachined filters, surface acoustic wave filters, micromachined filters for millimeter wave frequencies; Various types of MEMS phase shifters; Ferroelectric phase shifters. Micromachined antennas: Micromachining techniques to improve antenna performance, reconfigurable antennas. Integration and Packaging: Role of MEMS packages, types of MEMS packages, module packaging, packaging materials and reliability issues.

**v) a) TEXT BOOKS**

- 1) Vijay Varadan, K. J. Vinoy, K. A. Jose, “RF MEMS and Their Applications”, Wiley, 2003.
- 2) Hector J. De Los Santos, “RF MEMS Circuit Design for Wireless Applications”, Artech House, 2002

b) REFERENCES

- 1) Gabriel M. Rebeiz, “RF MEMS: Theory, Design, and Technology”, Wiley, 2003
- 2) Eun Sok kim “Fundamentals of Micro electro mechanical Systems (MEMS)” McGraw Hill

vi) COURSE PLAN

Module	Contents	No. of hours
I	RF MEMS for wireless applications, MEMS technology and fabrication, mechanical modelling of MEMS devices, MEMS materials and fabrication techniques surface micromachining, Bulk micromachining, LIGA, Actuation Mechanisms in MEMS, Piezoelectric, Electrostatic, Thermal, Magnetic.	12
II	Introduction to MEMS switches; Capacitive shunt and series switches: Physical description, circuit model and electromagnetic modelling; Techniques of MEMS switch fabrication and packaging; Design of MEMS switches	12
III	Micromachined passive elements - micromachined inductors: Effect of inductor layout, reduction of stray capacitance of planar inductors, folded inductors, variable inductors and polymer-based inductors; MEMS Capacitors: Gap-tuning and area tuning capacitors, dielectric tunable capacitors.	12
IV	Principle of operation of - micromachined filters, surface acoustic wave filters, micromachined filters for millimetre wave frequencies; Various types of MEMS phase shifters; Ferroelectric phase shifters	12
V	Micromachined antennas: Micromachining techniques to improve antenna performance, reconfigurable antennas. Integration and Packaging: Role of MEMS packages, types of MEMS packages, module packaging, packaging materials and reliability issues.	12
	Total hours	60

**vii) ASSESSMENT PATTERN****Mark distribution**

Total Marks	Continuous Internal Evaluation Marks	End Semester Evaluation Marks	End Semester Examination Duration
150	50	100	3 Hours

Continuous Internal Evaluation Pattern:

Attendance	10 Marks
Continuous Assessment Tests (2 numbers)	25 Marks
Assignment/Quiz/Course project	15 Marks

End Semester Examination Pattern:

There will be two parts; Part A and Part B. Part A contain 10 questions with 2 questions from each module, having 3 marks for each question. Students should answer all questions. Part B contains 2 questions from each module of which student should answer any one. Each question can have maximum 2 sub-divisions and carry 14 marks.



Course Code	Course Name	Category	L	T	P	Credit	Year of Introduction
EC1H40B	DESIGN AND ANALYSIS OF ANTENNAS	VAC	4	0	0	4	2020

i) **PREREQUISITE:** EC1U30E-ELECTROMAGNETICS, EC1U40A-MICROWAVE AND ANTENNAS

ii) COURSE OVERVIEW

This course aims to impart knowledge on the basic parameters, matching techniques, design and working of various broad band antennas, practical antennas, antenna arrays and its radiation patterns. It also introduces standard software to design antennas with a set of given specifications.

iii) COURSE OUTCOMES

After the completion of the course, the student will be able to

Course Outcomes	Description	Level
CO 1	Understand the concept of radiation mechanism, antenna parameters and antenna matching techniques.	Understand
CO 2	Illustrate the far field pattern of different types of antennas.	Understand
CO 3	Analyze different types of broad band antennas and its radiation patterns	Apply
CO 4	Design of various practical antennas, antenna arrays and field patterns	Apply
CO 5	Familiarize Antenna Design Software and design microstrip patch antenna.	Apply

iv) SYLLABUS

Review of Antenna Parameters, Relation between radiation fields and magnetic vector potential, Antenna matching, Review of different antennas, Analysis of Circular Loop and Biconical Antenna, Helical Antennas, Current induced in a dipole antenna, Near fields of linear antennas, self and mutual impedance, arrays of parallel dipoles, Yagi-Uda antennas, Radiation from open-ended wave-guides, Designing an antenna with a set of given specifications using standard software, Parabolic reflector antennas, gain and beam width of reflector antennas, aperture field and current distribution methods, radiation patterns of reflector antenna, Frequency independent antennas, Antenna arrays, Adaptive Beam forming. 2D arrays – Rectangular and Circular array.

v) a) TEXT BOOKS

- 1) Sopholes J. Orfanidis – Electromagnetic waves and antennas. Available at: <http://eceweb1.rutgers.edu/~orfanidi/ewa/>
- 2) Consrantive A Balanis -Antenna Theory - Analysis and Design – 2/e John Wiley & Sons.
- 3) John D. Krans, Ronald J. Marhefka : Antennas for all Applications , 3/e, TMH
- 4) Thomas A Milligan – Modern Antenna Design, 2/e John Wiley & Sons.

**b) REFERENCES**

- 1) Collin R.E, Antennas & Radio Wave Propagation, McGraw Hill. 1985.
- 2) Jordan E.C. & K. G. Balmain, Electromagnetic Waves & Radiating Systems, 2/e, PHI.
- 3) Raju G.S.N., Antenna and Wave Propagation, Pearson, 2013.
- 4) Sisir K.Das & Annapurna Das, Antenna and Wave Propagation, McGraw Hill, 2012

vi) COURSE PLAN

Module	Contents	No. of hours
I	Review of Antenna Parameters: -Polarization, Input impedance, Gain. Relation between radiation fields and magnetic vector potential – Helmholtz equation and Lorentz conditions. Antenna matching – T match, Baluns, Gamma and Omega match. Review of dipole antennas (short dipole and arbitrary length), Monopole antennas, V and rhombic antennas. Folded dipole and its properties.	12
II	Analysis of Circular Loop and Biconical Antenna. Helical Antennas (normal mode and axial mode) – relation for far fields, radiation resistance and gain. Current induced in a dipole antenna – Pocklington and Hallen's integral equations. Solution of Hallen's integral equation for current induced in a dipole antenna for delta gap model.	12
III	Near fields of linear antennas, self and mutual impedance, arrays of parallel dipoles, Yagi-Uda antennas. Aperture antenna – Field equivalence principle. Radiation from open-ended wave-guides, horn antennas, horn radiation fields, horn directivity, optimum horn design, Rectangular micro-strip antennas – field analysis and design. Designing an antenna with a set of given specifications using standard software (MATLAB/HFSS/CST Microwave Studio or any Open software)	13
IV	Parabolic reflector antennas, gain and beam width of reflector antennas, aperture-field and current distribution methods, radiation patterns of reflector antennas, dualreflector antennas, lens antennas -hyperbolic lens and zoned lens. Frequency independent antennas – Rumsey Principle – Spiral Antennas. Design of log periodic dipole arrays.	11
V	Antenna arrays – General expression for array factor. Grating lobes. One dimensional arrays- Broad side, end fire and Chebyshev arrays. Concept of beam steering. Design of array using Schelkunoff's zero placement method and Fourier series method. Woodward-Lawson frequency-sampling design, Narrow beam design and Butler matrix beam former. Adaptive Beam forming. 2D arrays – Rectangular and Circular array.	12
	Total hours	60

**vii) ASSESSMENT PATTERN****Mark distribution**

Total Marks	Continuous Internal Evaluation Marks	End Semester Evaluation Marks	End Semester Examination Duration
150	50	100	3 Hours

Continuous Internal Evaluation Pattern:

Attendance	10 Marks
Continuous Assessment Tests (2 numbers)	25 Marks
Assignment/Quiz/Course project	15 Marks

End Semester Examination Pattern:

There will be two parts; Part A and Part B. Part A contain 10 questions with 2 questions from each module, having 3 marks for each question. Students should answer all questions. Part B contains 2 questions from each module of which student should answer any one. Each question can have maximum 2 sub-divisions and carry 14 marks.

Simulation Assignments

The following simulation assignments can be done with MATLAB/HFSS/CST Microwave Studio or any Open software.

- Design a rectangular microstrip antenna (using MATLAB) for 1.8 GHz with RT-Duroid 5880 FR4 substrate having permittivity 4.4, loss tangent=0.001 and $h=1.6\text{mm}$ and also plot 3D, 2D radiation patterns and VSWR.
- The dimensions of a rectangular microstrip antenna are: $L=3.733\text{cm}$ and $W=3.973\text{cm}$. The substrate height $h=1.6\text{mm}$ and dielectric constant = 4.4. If operating frequency is 1.8 GHz. Write a MATLAB program to calculate
 - (a) The input impedance
 - (b) The position of the inset feed point for matching to 50 ohm feeder line.



Course Code	Course Name	Category	L	T	P	Credit	Year of Introduction
EC1H40C	MULTIRATE SIGNAL PROCESSING AND WAVELETS	VAC	4	0	0	4	2020

i) **PREREQUISITE:** EC1U30B - Digital Signal processing

ii) **COURSE OVERVIEW:**

The aim of this course is to introduce the idea of wavelets, and the related notions of time frequency analysis, of time-scale analysis, and to describe the way in which technical developments related to wavelets have led to numerous applications. The concepts of multirate filter banks are also introduced. The relation between wavelets and multirate systems is brought out to illustrate how wavelets may be realized in practice.

iii) **COURSE OUTCOMES**

After the completion of the course, the student will be able to:

Course Outcomes	Description	Level
CO 1	Explain the concepts, properties and interconnection of Multirate systems, Wavelets and Filterbanks and apply them in the analysis of signal processing systems.	Understand
CO 2	Design wavelets and multirate systems using the time domain and the frequency domain approaches.	Apply
CO 3	Apply the wavelet transform, wavelet packet transform and its variants as a tool in 1-D and 2-D signal analysis and processing.	Apply

iv) **SYLLABUS**

Basics of Multirate processing and Filter banks: Introduction to multiresolution and multirate signal processing with some example applications, Multirate System Fundamentals, Noble Identities. Introduction to digital filter banks, Perfect Reconstruction.

Introduction to Wavelet Transform:

The Uncertainty Principle, Short Time Fourier Transform, The Gabor Transform and its generalization, Wavelet Transform – CWT and DWT, Families of wavelets: Orthogonal and biorthogonal wavelets, Vanishing moments and regularity.

The Multiresolution Analysis (MRA), Wavelets and Filter Banks:

The Multiresolution Analysis and Orthogonality, The Haar Filter Bank, The Daubechies' family of MRA, Daubechies' Filter banks,

Biorthogonal Wavelets:

Introduction to biorthogonal Wavelet Systems, Signal representation and Construction of Biorthogonal wavelets, Design of Wavelet systems, Design of Daubechies Wavelets using frequency domain approach, JPEG 2000 5/3 filter bank and Spline MRA.

Wavelet packets and 2-D DWT:



The wavelet packet transform, Introduction to 2-D DWT, Embedded Zero-tree Wavelet (EZW) Coding. Applications of wavelets.

v) a) TEXT BOOKS

- 1) Bernard P. P. Vaidyanathan, Multirate Systems and Filter Banks, Pearson Education, 2006.
- 2) K. P. Soman, K. I. Ramachandran, "Insight Into Wavelets - From Theory to Practice", Prentice Hall of India, 3rd Edition, Eastern Economy Edition, Prentice Hall of India Private Limited, 2010. Video lectures and Transcripts: Adv. Digital Signal Processing: Multirate and Wavelet NPTEL Lecture series - <https://nptel.ac.in/courses/117/101/117101001/>

b) REFERENCES

- 1) Simon Rulph Gilbert Strang and Truong Q. Nguyen, Wavelets and Filter banks, 2nd Edition, Wellesley- CambridgePress,1998
- 2) Raghuvver M. Rao, Ajit S. Bopardikar, "Wavelet Transforms: Introduction to Theory and Applications, Prentice Hall, 1998.
- 3) N.J. Fliege, Multirate Digital Signal Processing, John Wiley, 1999.

vi) COURSE PLAN

Module	Contents	No. of hours
I	<p>Basics of Multirate processing and Filter banks:</p> <p>Introduction to multiresolution and multirate signal processing with some example applications, Multirate System Fundamentals: Basic multirate operations – Decimation and Interpolation, Transform domain analysis of Decimators and Interpolators, Decimation and Interpolation filters, Fractional sampling rate alteration Interconnection of decimators and interpolators, The Noble Identities. Introduction to digital filter banks, The DFT filter bank, Two Channel Quadrature Mirror Filterbank (QMF), Two channel Conjugate Quadrature Filter Bank (CQF). Perfect Reconstruction.</p>	13
II	<p>Introduction to Wavelet Transform:</p> <p>The Uncertainty Principle - Time-bandwidth product uncertainty, The time frequency plane and its tilings, Short Time Fourier Transform, The Gabor Transform and its generalization, Wavelet Transform in general and origin of Wavelets. The Continuous Wavelet Transform (CWT), Condition of admissibility and its implications.</p> <p>Introduction to Discrete Wavelet Transform (DWT), DWT from CWT, Logarithmic Scale Discretization and Dyadic Discretization, Families of wavelets: Orthogonal and biorthogonal wavelets, Vanishing moments and regularity.</p>	12



III	<p>The Multiresolution Analysis (MRA), Wavelets and Filter Banks:</p> <p>The Multiresolution Analysis: The Dyadic Haar Multiresolution Analysis - The Haar Scaling Functions and Function spaces, Nested spaces, The Haar Wavelet function, Orthogonality of the Haar Scaling and Wavelet functions. Relating Scaling and Wavelet functions of Haar and Filters, The Haar Filter Bank, Z-domain analysis of Haar filter bank. The Daubechies' family of MRA, Daubechies' Filter banks, Relating QCF filter banks and Daubechies' wavelets.</p>	12
IV	<p>Biorthogonal Wavelets:</p> <p>Introduction to biorthogonal vector space, Biorthogonal Wavelet Systems, Signal representation using Biorthogonal Wavelet System, Construction of Biorthogonal wavelets Design of Wavelet systems using frequency domain approach – Frequency domain characterisation of filter coefficients, Design of Daubechies Wavelets using frequency domain approach, JPEG 2000 5/3 filter bank and Spline MRA.</p>	12
V	<p>Wavelet packets and 2-D DWT:</p> <p>The wavelet packet transform, Best wavelet packet tree, Noble identities and the Haar wave Packet Transform. Introduction to 2-D DWT, Wavelet transform of an image, The Embedded Zero-tree Wavelet (EZW) Coding. Applications of wavelets in audio & image compression and denoising.</p>	11
Total hours		60

ASSESSMENT PATTERN**Mark distribution**

Total Marks	Continuous Internal Evaluation Marks	End Semester Evaluation Marks	End Semester Examination Duration
150	50	100	3 Hours

Continuous Internal Evaluation Pattern:

Attendance	10 Marks
Continuous Assessment Tests (2 numbers)	25 Marks
Assignment/Quiz/Course project	15 Marks

End Semester Examination Pattern:

There will be two parts; Part A and Part B. Part A contain 10 questions with 2 questions from each module, having 3 marks for each question. Students should answer all questions. Part B contains 2 questions from each module of which student should answer any one. Each question can have maximum 2 sub-divisions and carry 14 marks.



SEMESTER VIII



Course Code	Course Name	Category	L	T	P	Credit	Year of Introduction
EC1U40B	WIRELESS COMMUNICATION	PCC	3	0	0	3	2020

i) COURSE OVERVIEW

This course aims to introduce students to basic theory and principles of wireless communication systems in general, and cellular systems in particular. It also introduces basics of radio wave propagation.

ii) COURSE OUTCOMES

After the completion of the course, the student will be able to:

Course Outcomes	Description	Level
CO 1	Summarize the basics of cellular system and cellular design fundamentals.	Understand
CO 2	Describe the wireless channel models and discuss capacity of wireless channels.	Understand
CO 3	Analyze the performance of the modulation techniques for flat-fading channels and multicarrier modulation.	Apply
CO 4	Illustrate how receiver performance can be enhanced by various diversity techniques.	Apply
CO 5	Identify advantages of various equalization techniques and multiple-access techniques in wireless communication.	Understand
CO 6	Calculate system parameters such antenna height, range, maximum usable frequency in different modes of radio wave propagation.	Apply

iii) SYLLABUS

Introduction to Wireless Communication Systems: Generations: 2G, 3G, 4G, 5G. Wireless LAN, Bluetooth and Personal Area networks, Broadband Wireless Access WiMAX Technology. Wireless Spectrum allocation, Standards.

Cellular System Design Fundamentals: Frequency Reuse, channel assignment strategies, Handoff strategies, Interference and system capacity, trunking and grade off service, improving coverage and capacity – cell splitting, sectoring, microcells.

Path loss and shadowing: Free space path loss, Two-Ray model, Shadowing

Statistical Multipath Channel Models: Time-varying channel impulse response, Narrowband fading, Wideband fading models, Delay spread and Coherence bandwidth, Doppler spread and Coherence time, Flat fading versus frequency selective fading, Slow fading versus fast fading, Discrete-time model.

Capacity of Wireless Channels: Review of Capacity in AWGN, Capacity of flat fading channel – Ergodic capacity, Capacity with Outage, Capacity with CSI-R. (Derivations of capacity formulae are not required; Only expressions, computations and significance required.)

Digital Signaling for Flat fading Channels: Analysis of Average Error Probability and Outage probability of BPSK in flat-fading channels.



Multi-carrier Modulation: Data transmission using multicarrier modulation for frequency-selective fading channels. Overlapping subchannels, Mitigation of Subcarrier Fading, Discrete Implementation of multicarrier – OFDM. Cyclic prefix, Peak-to-average power

Diversity: Receiver diversity – selection combining, maximal ratio combining. Transmitter diversity – Alamouti scheme for 2x2 MIMO.

Equalization: Equalization – Linear and non-linear equalization, Zero forcing, MMSE equalizers. LMS algorithm. Adaptive Equalization.

Multiuser Systems: Uplink and Downlink, Multiple Access, Frequency-Division Multiple Access (FDMA), Time-Division Multiple Access (TDMA), Code-Division Multiple Access (CDMA), Orthogonal Frequency-Division Multiple Access (OFDMA).

Radio Wave Propagation: Ground wave propagation, Plane earth reflection, Space wave and surface wave, Spherical earth propagation, Tropospheric waves, Ionospheric propagation, Effects of earth's magnetic field, Critical frequency, Maximum usable Frequency, Virtual height.

iv) a) TEXT BOOKS

1. Andrea Goldsmith, Wireless Communications, Cambridge University Press, 2005
2. Theodore S. Rappaport, Wireless communication: Principles and Practice, 2/e, Pearson Education, 1990.
3. Aditya Jagannatham, Principles of Modern Wireless Communication Systems, Mc Graw Hill, 2017.
4. Robert Collin, Antennas and Radiowave Propagation, McGraw Hill, 2016.

b) REFERENCES

1. David Tse and Pramod Viswanath, Fundamentals of Wireless Communication, Cambridge University Press, 2005
2. Jochen Schiller, Mobile Communications, Pearson, 2008.
3. Andreas F Molish, Wireless Communications, 2nd Edition , Wiley India Publications, 2013.
4. W. C. Y. Lee, Mobile Cellular Telecommunication, McGraw Hill, 2017.
5. Gordon L. Stuber, Principles of Mobile Communication , Springer, 2017
6. Rahim Thafazoli, Technologies for The Wireless Future , Volume 2 , Wiley and Sons, 2004.
7. Edward C Jordan and Keith G Balmain, Electromagnetic Wave and Radiating System, Pearson.



v) COURSE PLAN

Module	Contents	No. of hours
I	Introduction to wireless communication systems: Generations: 2G, 3G, 4G, 5G., Wireless LAN, Bluetooth and Personal Area networks, Broadband Wireless Access -- WiMAX Technology. Wireless Spectrum allocation, Standards. Cellular concept, Frequency Reuse, channel assignment strategies, Handoff strategies, Interference and system capacity, trunking and grade off service. improving coverage and capacity – cell splitting, sectoring, microcells.	9
II	Wireless Channels- Free space path loss, Two-Ray model, Shadowing, Time-varying channel impulse response, Narrowband fading, Wideband fading models – Delay spread and Coherence bandwidth, Doppler spread and Coherence time, Flat fading versus frequency selective fading, Slow fading versus fast fading, Discrete-time model. Review of Capacity in AWGN, Capacity of flat fading channel – Ergodic capacity, Capacity with Outage, Capacity with CSI-R.	9
III	Modulation Techniques-Average Probability of error and outage probability, Performance evaluation of BPSK in flat fading channels, Multi carrier modulation in frequency-selective channel, OFDM – DFT/IDFT, Cyclic Prefix,PAPR.	9
IV	Diversity,Equalization and Multiple Access- Receiver Diversity – Selection combining, Maximal ratio combining, Transmit Diversity – Alamouti for 2x2 MIMO, Equalization – linear and nonlinear, ZF and MMSE, LMS, Adaptive, Multiple access – FDMA, TDMA, CDMA, OFDMA	9
V	Radio Wave Propagation- Ground wave propagation, Plane earth reflection, Space wave and surface Wave, Spherical earth propagation, Tropospheric waves, Ionospheric Propagation, Effects of earth's magnetic field, Critical frequency, Maximum usable Frequency, Virtual height.	9
	Total hours	45

**vi) ASSESSMENT PATTERN****Mark distribution**

Total Marks	Continuous Internal Evaluation Marks	End Semester Evaluation Marks	End Semester Examination Duration
150	50	100	3 Hours

Continuous Internal Evaluation Pattern:

Attendance	10 Marks
Continuous Assessment Tests (2 numbers)	25 Marks
Assignment/Quiz/Course project	15 Marks

End Semester Examination Pattern:

There will be two parts; Part A and Part B. Part A contain 10 questions with 2 questions from each module, having 3 marks for each question. Students should answer all questions. Part B contains 2 questions from each module of which student should answer any one. Each question can have maximum 2 sub-divisions and carry 14 marks.



PROGRAMME ELECTIVE-III

Course Code	Course Name	Category	L	T	P	Credit	Year of Introduction
EC1U42A	BIOMEDICAL ENGINEERING	PEC	3	0	0	3	2020

i) COURSE OVERVIEW

This course will introduce aspects of biomedical engineering as applied to biological systems described using engineering principles and the use of modern diagnostic and therapeutic equipment.

ii) COURSE OUTCOMES

After the completion of the course, the student will be able to:

Course Outcomes	Description	Level
CO 1	To explain the functioning of physiological systems and generation of bioelectric potentials and its implications in diagnostics	Understand
CO 2	To describe the principles used for diagnosis of abnormalities in the cardiovascular system	Understand
CO 3	To explain the techniques used for diagnosis and therapy in the neuromuscular and respiratory system	Understand
CO 4	To explain the principle and working of different types of bio medical equipment/device	Understand
CO 5	Classify various diagnostic medical imaging techniques.	Understand

iii) SYLLABUS

Introduction to bio-medical engineering, overview of anatomy and physiological systems of the body. Sources of bio-electric potential: Resting and action potential, propagation of action potentials. Bioelectric potentials examples (ECG, EEG, EMG, ERG, EOG, EGG concept only.) Electrode theory: Nernst relation, Electrode skin interface, Bio potential electrodes: Microelectrodes, skin surface electrodes, needle electrodes Instrumentation for clinical laboratory: Bio potential amplifiers-instrumentation amplifiers, carrier amplifiers, isolation amplifiers, chopper amplifiers.

Heart and cardiovascular system (brief discussion), electro conduction system of the heart. Electrocardiography, ECG machine block diagram, ECG lead configurations, ECG recording system, Einthoven triangle, analysis of ECG signals. Measurement of blood pressure: Direct, indirect and relative methods of blood pressure measurement, auscultatory method, oscillometric and ultrasonic non-invasive pressure measurements. Measurement of blood flow: Electromagnetic blood flowmeters and ultrasonic blood flow meters

The human nervous system. Neuron, action potential of brain, brain waves, types of electrodes, placement of electrodes, evoked potential, EEG recording, analysis of EEG. Electrical activity of muscles- EMG. Signal Acquisition and analysis. Applications of EMG - myoelectric control system. Electrical stimulation of the muscle and nerve, Functional Electrical Stimulation- Principle and applications. Physiology of respiratory system



(overview), Respiratory parameters, spirometer, body plethysmographs, gas exchange and distribution.

Instruments for clinical laboratory: Oxymeters, pH meter, blood cell counter, flame photometer, spectrophotometer. Therapeutic Equipments: Principle, block schematic diagram, working and applications of : pacemakers, cardiac defibrillators, heart–lung machine, dialyzers, surgical diathermy equipment, ventilators Biomedical Telemetry system: Components of biotelemetry system, application of telemetry in medicine, single channel telemetry system for ECG and temperature measurement

Medical Imaging systems (Basic Principle only): X-ray imaging - Properties and production of Xrays, X-ray machine, applications of X-rays in medicine. Computed Tomography: Principle, image reconstruction, scanning system and applications Ultrasonic imaging systems: Basic pulse echo system, propagation of ultrasonic through tissues and reflections, display types, A-Scan, B-Scan, M-Scan, applications, real-time ultrasonic imaging systems and probes. Magnetic Resonance Imaging – Basic NMR components, Biological effects and advantages of NMR imaging Patient Safety: Electric shock hazards, leakage current, safety codes for electro medical equipments

(a) TEXT BOOKS

- 1) R. S. Khandpur, Handbook of Biomedical Instrumentation, Tata Mc Graw Hill.
- 2) Leslie Cromwell, Fred J. Weibell, Erich A. Pfeiffer, Biomedical Instrumentation and Measurements, PHI, 2nd Edition, 2004

(b) REFERENCES

- 1) John G Webster, “Medical Instrumentation application and design”, John Wiley 3rde/d
- 2) J. J. Carr, “Introduction to Biomedical Equipment Technology”, Pearson Education 4th e/d.
- 3) Richard Aston, “Principle of Biomedical Instrumentation and Measurement”. Merrill Education/Prentice Hall.
- 4) Barbara Christe, Introduction to Biomedical Instrumentation, Cambridge University Press, 2008

iv) COURSE PLAN

Module	Contents	No. of hours
I	Introduction to bio-medical engineering, overview of anatomy and physiological systems of the body. Sources of bio-electric potential: Resting and action potential, propagation of action potentials. Bioelectric potentials examples (ECG, EEG, EMG, ERG, EOG, EGG concept only.) Electrode theory: Nernst relation, Electrode skin interface, Bio potential electrodes: Microelectrodes, skin surface electrodes, needle electrodes Instrumentation for clinical laboratory: Bio potential amplifiers-instrumentation amplifiers, carrier amplifiers, isolation amplifiers,	9



	chopper amplifiers.	
II	Heart and cardiovascular system (brief discussion), electro conduction system of the heart. Electrocardiography, ECG machine block diagram, ECG lead configurations, ECG recording system, Einthoven triangle, analysis of ECG signals. Measurement of blood pressure: Direct, indirect and relative methods of blood pressure measurement, auscultatory method, oscillometric and ultrasonic non-invasive pressure measurements. Measurement of blood flow: Electromagnetic blood flowmeters and ultrasonic blood flow meters	9
III	The human nervous system. Neuron, action potential of brain, brain waves, types of electrodes, placement of electrodes, evoked potential, EEG recording, analysis of EEG. Electrical activity of muscles- EMG. Signal Acquisition and analysis. Applications of EMG - myoelectric control system. Electrical stimulation of the muscle and nerve, Functional Electrical Stimulation- Principle and applications. Physiology of respiratory system (overview), Respiratory parameters, spirometer, body plethysmographs, gas exchange and distribution.	9
IV	Instruments for clinical laboratory: Oxymeters, pH meter, blood cell counter, flame photometer, spectrophotometer. Therapeutic Equipments: Principle, block schematic diagram, working and applications of : pacemakers, cardiac defibrillators, heart–lung machine, dialyzers, surgical diathermy equipment, ventilators Biomedical Telemetry system: Components of biotelemetry system, application of telemetry in medicine, single channel telemetry system for ECG and temperature measurement	9
V	Medical Imaging systems (Basic Principle only): X-ray imaging - Properties and production of Xrays, X-ray machine, applications of X-rays in medicine. Computed Tomography: Principle, image reconstruction, scanning system and applications Ultrasonic imaging systems: Basic pulse echo system, propagation of ultrasonic through tissues and reflections, display types, A-Scan, B-Scan, M-Scan, applications, real-time ultrasonic imaging systems and probes. Magnetic Resonance Imaging – Basic NMR components, Biological effects and advantages of NMR imaging Patient Safety: Electric shock hazards, leakage current, safety codes for electro medical equipments	9
	Total hours	45

**vi) ASSESSMENT PATTERN****Mark distribution**

Total Marks	Continuous Internal Evaluation Marks	End Semester Evaluation Marks	End Semester Examination Duration
150	50	100	3 Hours

Continuous Internal Evaluation Pattern:

Attendance	10 Marks
Continuous Assessment Tests (2 numbers)	25 Marks
Assignment/Quiz/Course project	15 Marks

End Semester Examination Pattern:

There will be two parts; Part A and Part B. Part A contain 10 questions with 2 questions from each module, having 3 marks for each question. Students should answer all questions. Part B contains 2 questions from each module of which student should answer any one. Each question can have maximum 2 sub-divisions and carry 14 marks.



Course Code	Course Name	Category	L	T	P	Credit	Year of Introduction
EC1U42B	SATELLITE COMMUNICATION	PEC	3	0	0	3	2020

PRE-REQUISITE: EC1U30C -Analog &Digital communication

COURSE OVERVIEW: This course aims to impart the basic knowledge of satellite communication and its applications.

i) COURSE OUTCOMES

After the completion of the course, the student will be able to:

Course Outcomes	Description	Level
CO 1	Explain the basic concepts of satellite communication and satellite orbits.	Understand
CO 2	Describe satellite communication subsystems & launching mechanisms of satellites.	Understand
CO 3	Calculate satellite link budgets.	Apply
CO 4	Explain the various methods of satellite access.	Understand
CO 5	Discuss various applications of satellite communications.	Understand

ii) SYLLABUS

Satellite Orbits:

Introduction to Satellite Communication, Historical background, Basic concepts of Satellite Communications, Kepler's laws of planetary motion, types of satellite orbits, orbit determination. Definitions of terms for Earth-Orbiting Satellites, Orbital Elements, Apogee and Perigee Heights, satellite stabilization, orbital effects on satellites performance. Antenna Look Angles, The Polar Mount Antenna, Limits of Visibility, launch systems for geostationary satellites.

Satellite System:

The Space Segment Introduction, The Power Supply, Attitude Orbit Control, Satellite stabilization, Station Keeping, Thermal Control, TT&C Subsystem, Transponders, Antenna Subsystem

The Earth Segment
Types of earth station, architecture & design considerations. Transmit-Receive Earth Station, Wideband receiver, the input demultiplexer, the power amplifier, Satellite tracking.

The Satellite Link design:

Introduction, Transmission Theory, System Noise Temperature and G/T Ratio, Design of Downlinks

Ku-Band GEO Satellite Systems, Uplink Design, Design for Specified CNR: Combining CNR and C/I Values in Satellite Links, System Design for Specific Performance. Regional & global satellite systems INSAT, INTELSAT & INMARSAT.

Modulation & Multiple Access



Introduction, Digital Modulation techniques preferred in satellites, Multiple Access, Frequency Division Multiple Access(FDMA) , Time Division Multiple Access (TDMA), Transmitter Power in TDMA Networks, Demand Assignment Multiple Access (DAMA), Random Access (RA) , Packet Radio Systems and Protocols, Code Division Multiple Access (CDMA)

Satellite Application:

Introduction, Frequency bands, , Comparison between Satellite & terrestrial networks, Satellite Telephony, Satellite Television, DTH, Satellite Radio broadcasting, Remote Sensing Satellite; Classification, orbits, payloads, Weather Forecasting Satellites: Orbits, payloads.

Navigation Satellite: Basic principles of satellite navigation, GPS Position Location Principle functional segments of GPS, Indian Contribution to positioning systems. NGSO satellite systems.

iii) (a) TEXT BOOKS

1. Dennis Roddy, Satellite Communications, 4th Edition, McGraw- Hill International edition, 2006
2. Timothy Pratt,Jeremy E,Allnut, Satellite Communications, Wiley, 3rd Edition, October 2019

b) References:

1. Gerard Maral,Michel Bousquet,Zhili Sun, Satellite Communications Systems: Systems, Techniques and Technology,Wiley,6thedition,April 2020
2. Anil K. Maini, Varsha Agrawal, Satellite Communications, Wiley India Pvt. Ltd., 2015
3. TRI.T. HA, Digital Satellite Communications, McGraw-Hill,second edition

iv) COURSE PLAN

Module	Contents	No. of hours
I	Introduction to Satellite Communication, Historical background, Basic concepts of Satellite Communications, Kepler's laws of planetary motion, types of satellite orbits, orbit determination. Definitions of terms for Earth-Orbiting Satellites, Orbital Elements, Apogee and Perigee Heights, satellite stabilization, orbital effects on satellite performance. Antenna Look Angles, The Polar Mount Antenna, Limits of Visibility, launch systems for geostationary satellites.	9
II	The Space Segment Introduction, The Power Supply, Attitude & Orbit Control, Satellite stabilization, Station Keeping, Thermal Control, TT&C Subsystem, Transponders, Antenna Subsystem The Earth Segment Types of earth station, architecture & design considerations .Transmit-Receive Earth Station ,Wideband receiver, the input demultiplexer, the power amplifier, Satellite tracking.	10
III	Introduction, Transmission Theory, System Noise Temperature and G/T Ratio, Design of Downlinks Ku-Band GEO Satellite Systems, Uplink Design , Design for Specified CNR: Combining CNR and C/I Values in Satellite Links ,System Design for Specific Performance. Regional & global satellite systems	8



	INSAT, INTELSAT& INMARSAT.	
IV	Introduction, Digital Modulation techniques preferred in satellites, Multiple Access ,Frequency Division Multiple Access (FDMA) , Time Division Multiple Access (TDMA), Transmitter Power in TDMA Networks, Demand Assignment Multiple Access (DAMA), Random Access (RA) , Packet Radio Systems and Protocols, Code Division Multiple Access (CDMA)	9
V	Introduction, Frequency bands, , Comparison between Satellite & terrestrial networks, Satellite Telephony, Satellite Television, DTH, Satellite Radio broadcasting, Remote Sensing Satellite; Classification, orbits, payloads, Weather Forecasting Satellites: Orbits, payloads. Navigation Satellite: Basic principles of satellite navigation, GPS Position Location Principle functional segments of GPS, Indian Contribution to positioning systems. NGSO satellite systems.	9
	Total hours	45

v) ASSESSMENT PATTERN

Mark distribution

Total Marks	Continuous Internal Evaluation Marks	End Semester Evaluation Marks	End Semester Examination Duration
150	50	100	3 Hours

Continuous Internal Evaluation Pattern:

Attendance	10 Marks
Continuous Assessment Tests (2 numbers)	25 Marks
Assignment/Quiz/Course project	15 Marks

END SEMESTER EXAMINATION PATTERN

There will be two parts; Part a and Part B. Part A contain 10 questions with 2 questions from each module, having 3 marks for each question. students should answer all questions. Part B contains 2 questions from each module of which student should answer any one. Each question can have maximum 2 sub-divisions and carry 14 marks.



Course Code	Course Name	Category	L	T	P	Credit	Year of Introduction
EC1U42C	SECURE COMMUNICATION	PEC	3	0	0	3	2020

i) **PREREQUISITE:** Nil

ii) **COURSE OVERVIEW**

This course aims to provide an insight into the theory and technology behind secure communication.

iii) **COURSE OUTCOMES**

After the completion of the course the student will be able to:

Course Outcomes	Description	Level
CO 1	Explain network security services and mechanisms and the types of attacks they are designed for.	Understand
CO 2	Model the symmetric encryption process and different encryption techniques	Apply
CO 3	Apply the concepts of group, ring, field, modular arithmetic, Euclidean algorithm, Finite fields and polynomial arithmetic	Apply
CO 4	Illustrate the principles of modern symmetric ciphers like the Data Encryption Standard and Advanced Encryption Standard	Understand
CO 5	Outline the concepts of public key cryptography, RSA algorithm, key distribution and management for public key systems	Understand
CO 5	Explain the requirements for authentication and the types of functions used to produce an authenticator	Understand

iv) **SYLLABUS**

Introduction and Classic Encryption Techniques. Groups,Rings and Fields, Modular arithmetic, Euclidian algorithm, Finite Fields of the form $GF(p)$, Polynomial arithmetic

Block Cipher Principles – Stream Ciphers and Block Ciphers, Feistel Cipher, The Data encryption standard,The AES Standard.,

Principles of public key cryptosystems-Fermat's theorem, Euler's Totient Function, Euler's theorem,RSA algorithm, Key management.

Authentication requirements, Authentication functions- Message Encryption, Public Key Encryption, Message Authentication Code, Hash function

**v) (a) Text Books**

1. William Stallings, Cryptography and Network security: principles and practice", 4th Edition, Prentice Hall of India, New Delhi, 2006

(b) Reference Books:

1. Behrouz A. Forouzan, Cryptography and Network security Tata McGraw-Hill, 2008
2. David S. Dummit& Richard M Foote, Abstract Algebra, 2nd Edition, Wiley India Pvt.Ltd.,2008.
3. Douglas A. Stinson, Cryptography, Theory and Practice, 2/e, Chapman & Hall, CRC Press Company, Washington, 2005.
4. Lawrence C. Washington, Elliptic Curves: Theory and Cryptography, Chapman &Hall, CRCPress Company, Washington, 2008.N.
5. Koeblitz: A course in Number theory and Cryptography, 2008
6. Thomas Koshy: Elementary Number Theory with Applications, 2/e, Academic Press,2007
7. Tyagi and Yadav, Cryptography and network security, Dhanpatrai, 2012

vi) COURSE PLAN

Module	Contents	No. of hours
I	Introduction and Classic Encryption Techniques OSI security architecture, Security attacks – Passive attacks, Active attacks, Security services- Authentication, Access Control, Data Confidentiality, Data integrity, Nonrepudiation, Availability service. Model for network security. Symmetric cipher model, Cryptography, Cryptoanalysis, Substitution techniques- Hill Cipher, One time pad, Transposition Techniques.	9
II	Finite Fields: Groups, Rings and Fields, Modular arithmetic, Euclidian algorithm, Finite Fields of the form $GF(p)$, Polynomial arithmetic	10
III	Block Ciphers. Data Encryption Standard, AES Cipher Block Cipher Principles – Stream Ciphers and Block Ciphers, Feistel Cipher, Feistel Decryption algorithm, The Data encryption standard, DES Decryption - Avalanche effect, The AES Cipher, substitute bytes transformation, Shift row transformation, Mix Column transformation	11
IV	Public Key Cryptography, RSA and Key Management Principles of public key cryptosystems-Public key cryptosystems, Application for Public key cryptosystem requirements, Fermat's theorem, Euler's Totient Function, Euler's theorem, RSA algorithm, Key management, Distribution of public keys, Publicly available directory, Public key authority, public key certificates, Distribution of secret keys using public key cryptography	9
V	Message Authentication and Hash Function	



	Authentication requirements, Authentication functions- Message Encryption, Public Key Encryption, Message Authentication Code, Hash function	6
	Total hours	45

vii) ASSESSMENT PATTERN**Mark distribution**

Total Marks	Continuous Internal Evaluation Marks	End Semester Evaluation Marks	End Semester Examination Duration
150	50	100	3 Hours

Continuous Internal Evaluation Pattern:

Attendance	10 Marks
Continuous Assessment Tests (2 numbers)	25 Marks
Assignment/Quiz/Course project <i>Atleast one assignment should be simulation of one type transistor amplifier on any circuit simulation software.</i>	15 Marks

End Semester Examination Pattern:

There will be two parts; Part A and Part B. Part A contain 10 questions with 2 questions from each module, having 3 marks for each question. Students should answer all questions. Part B contains 2 questions from each module of which student should answer any one. Each question can have maximum 2 sub-divisions and carry 14 marks.



Course Code	Course Name	Category	L	T	P	Credit	Year of Introduction
EC1U42D	PATTERN RECOGNITION	PEC	3	0	0	3	2020

i) **PREREQUISITE:** MA0U10A -Linear Algebra and Calculus, MA0U20C -Probability, Random Process and Numerical Methods, Basics of Machine Learning.

ii) COURSE OVERVIEW

This course aims to impart the fundamentals of statistical pattern recognition and neural network techniques

iii) COURSE OUTCOMES

After the completion of the course, the student will be able to:

Course Outcomes	Description	Level
CO 1	Understand the basics of statistical pattern recognition	Understand
CO 2	Apply statistical methods in linear classification	Apply
CO 3	Apply linear algebra and statistical methods in parameter and non-parameter Estimation	Apply
CO 4	Apply statistical methods in non-linear classification and neural networks	Apply
CO 5	Understand the basics of deep learning networks, convolutional neural networks	Understand

iv) SYLLABUS

Basics of pattern recognition system, various applications, classification of pattern recognition systems, design of Pattern recognition system. Statistical pattern recognition: review of probability theory, Gaussian distribution, Bayes decision theory, optimal solutions for minimum error and minimum risk criteria.

Linear Classifiers, linearly separable classes, normal density, discriminant functions, decision surfaces, linear discriminants, binary class, multiple classes, cost functions, perceptron algorithm, SVM, Fisher's linear discriminant.

Parameter estimation methods: Maximum-Likelihood estimation, Bayesian parameter estimation, mixture models, mixtures of Gaussians, Expectation-maximization method.

Non-Parameter methods: Non-parametric techniques for density estimation - Parzen-window method, K-nearest neighbour density estimation, nearest neighbor rule.

Nonlinear classifiers, the XOR problem, two-layer multilayer perceptrons, multilayer perceptrons, neural networks, feed-forward networks, hidden units, activation function, weight vector, bias, cost functions, forward and backward propagation, learning by gradient descent, backpropagation algorithm.



Introduction to deep learning networks, deep feedforward networks, ReLU, bias-variance tradeoff, regularization, dropout, vanishing/exploding gradients, weight initialization for deep networks, basics of convolutional neural networks, layers of convolutional neural networks.

v) a) TEXT BOOKS

- 1) Bishop, C. M. "Pattern Recognition and Machine Learning" Springer, New York, 2006.
- 2) Duda, R.O., Hart, P.E., and Stork, D.G. "Pattern Classification". Wiley, New York, 2001.

b) REFERENCES

- 1) Hastie, T., Tibshirani, R. and Friedman, J. "The Elements of Statistical Learning". Springer. 2001.
- 2) Theodoridis, S. and Koutroumbas, K. "Pattern Recognition". Academic Press, San Diego, 2003.
- 3) Ian Goodfellow, Yoshua Bengio, Aaron Courville. "Deep Learning" MIT Press, 2016.
- 4) Morton Nadier and Eric Smith P., "Pattern Recognition Engineering", John Wiley & Sons, New York, 1993.

vi) COURSE PLAN

Module	Contents	No. of hours
I	Basics of pattern recognition system, various applications, types of pattern recognition systems, design of Pattern recognition system. Statistical pattern recognition: review of probability theory, Bayes decision theory, optimal solutions for minimum error and minimum risk criteria.	9
II	Linear Classifiers, linearly separable classes, normal density, discriminant functions, decision surfaces, linear discriminants, binary class, multiple classes, cost functions, perceptron algorithm, SVM, Fisher's linear discriminant.	9
III	Parameter estimation methods: Maximum-Likelihood estimation, Bayesian parameter estimation, mixture models, mixtures of Gaussians, Expectation-maximization method. Non-parametric techniques for density estimation - Parzen-window method, K-nearest neighbour density estimation, nearest neighbor rule.	9
IV	Nonlinear classifiers, the XOR problem, two-layer multilayer perceptrons, multilayer perceptrons, neural networks, feed-forward networks, hidden units, activation function, weight vector, bias, cost functions, forward and backward propagation, learning by gradient descent, backpropagation algorithm.	9



V	Introduction to deep learning networks, deep feedforward networks, ReLU, bias-variance tradeoff, regularization, dropout, vanishing/exploding gradients, weight initialization for deep networks, basics of convolutional neural networks, layers of convolutional neural networks	9
	Total hours	45

vii) ASSESSMENT PATTERN**Mark distribution**

Total Marks	Continuous Internal Evaluation Marks	End Semester Evaluation Marks	End Semester Examination Duration
150	50	100	3 Hours

Continuous Internal Evaluation Pattern:

Attendance	10 Marks
Continuous Assessment Tests (2 numbers)	25 Marks
Assignment/Quiz/Course project	15 Marks

Simulation Assignments (using Python or Matlab)

- Linear classifiers
- Maximum likelihood estimation,
- Bayesian estimation
- Expectation-maximization method.
- Multilayer perceptrons
- Backpropagation
- Deep learning examples
- Basic CNN

End Semester Examination Pattern:

There will be two parts; Part A and Part B. Part A contain 10 questions with 2 questions from each module, having 3 marks for each question. Students should answer all questions. Part B contains 2 questions from each module of which student should answer any one. Each question can have maximum 2 sub-divisions and carry 14 marks.



Course Code	Course Name	Category	L	T	P	Credit	Year of Introduction
EC1U42E	RF CIRCUIT DESIGN	PEC	3	0	0	3	2020

i) **PREREQUISITE:** EC1U30E -Electromagnetics, EC1U20D -Analog Circuits and EC1U20C - Network Theory

ii) COURSE OVERVIEW

This course deals with the analysis, design and simulation of Radio Frequency (RF) Circuits and Components for wireless communication systems. The course provides fundamentals of transmission lines, high frequency circuit behavior, impedance matching networks, filters, active RF components, amplifiers, and mixers. The course will enable the students to use CAD tools for simulating and designing RF circuits.

iii) COURSE OUTCOMES

After the completion of the course, the student will be able to:

Course Outcomes	Description	Level
CO 1	Explain the basic idea about RF networks and working of RF filter circuits	Understand
CO 2	Describe the behaviour of RF components and application of Network analyzer in parameter measurement	Understand
CO 3	Apply the principle of RF networks in the designing of RF amplifiers, RF Oscillators and Mixers	Apply

iv) SYLLABUS

Introduction to RF System: Importance of radio frequency design, RF behavior of resistors, inductors and capacitors. **Transmission Lines**-Equivalent Circuit representation-General Transmission Line Equation-Terminated transmission lines- Input impedance, Standing waves, VSWR, Return loss, Insertion loss, Characteristic impedance, Phase velocity, Planar Transmission Lines- Microstrip lines and Striplines- Constructional Features.

RF Network Analysis: Single and Multi-port Networks– Definitions-Impedance matrix, scattering matrix, Transmission (ABCD) matrix. **Impedance Matching Networks**-Design of Matching Circuits using Lumped Elements, Single Stub tuning, Quarter-Wave Transformers, Multi-Section Transformer -Binomial Transformer. **RF Filter Design**- Filter Design using insertion loss technique.

RF Components: Active RF components- Bipolar junction Transistor – Construction-Functionality-Power Frequency Limitations of High Frequency transistors, GaAs devices - Familiarization of RF Field Effect Transistors and High Electron Mobility Transistors-Constructional details, **RF circuit measurements and characterization**- Using Vector Network analyzer- S parameter, Reflection Coefficient and Insertion loss Measurement. **Modeling and Simulation of RF circuits using** – Open source or Commercial EM Simulation Software.

Radio Frequency Amplifiers: Amplifier design using S-parameters - Characteristics of Amplifier Power Relations, Stability Considerations – Stability Circles, Tests for Unconditional



Stability, **High frequency amplifier design** – Single stage amplifier Design – Design for maximum gain, Low noise amplifier design.

Radio Frequency Oscillators and Mixers: Basic oscillator model- Feedback oscillator design- Negative Resistance Oscillator- Dielectric Resonator Oscillator - YIG Tuned Oscillator. **Mixer** - Basic characteristics- Single-Ended Mixer Design, Single-balanced and double- balanced mixers.

v) a) **TEXT BOOKS**

- 1) Ludwig, Reinhold. RF Circuit Design: Theory & Applications, 2/e. Pearson Education India, 2000.
- 2) Pozar, David M. Microwave and RF design of wireless systems. John Wiley & Sons, 2000

b) **REFERENCES**

- 1) Radmanesh, Matthew M. Advanced RF & microwave circuit design: the ultimate guide to superior design. Author House, 2008.
- 2) Carr, Joseph J. Secrets of RF circuit design. McGraw-Hill Education, 2001.
- 3) Misra, Devendra K. Radio-frequency and microwave communication circuits: analysis and design. John Wiley & Sons, 2012.
- 4) Mathew M. Radmanesh, “Radio Frequency & Microwave Electronics”, 2nd Edition, Pearson Education Asia, 2002.
- 5) Rohde, Ulrich L., and David P. Newkirk. RF/microwave circuit design for wireless applications. John Wiley & Sons, 2000.
- 6) Davis, W. Alan, and Krishna Kumar Agarwal. Radio frequency circuit design. John Wiley, 2001.
- 7) Christopher, Bowick, Ajluni Cheryl, and Blyler John. RF Circuit Design. Newnes, 2007.
- 8) Abrie, Pieter LD. Design of RF and microwave amplifiers and oscillators. Artech House, 1999.

vi) **COURSE PLAN**

Module	Contents	No. of hours
I	Introduction to RF circuits- Importance of radio frequency design, RF behaviour of resistors , Inductors and capacitors, Transmission Lines- Equivalent Circuit representation- General Transmission Line Equation, Terminated transmission lines- Input Impedance Standing waves, VSWR, Return loss, Insertion loss, Characteristic impedance, Planar Transmission Lines- Microstrip lines and Striplines- Constructional Features	9
II	Single and Multi-port Networks- Impedance matrix, Scattering matrix, Transmission (ABCD) matrix, Impedance matching Network- Design of Matching Circuits using Lumped Elements, Single Stub Matching Quarter-Wave Transformers, Multi-Section Transformer- Binomial Transformer, RF Filter Design- Filter Design using insertion loss technique	9



Module	Contents	No. of hours
III	Active RF components - Bipolar junction Transistor – Construction - Functionality-Power Frequency Limitations of High Frequency transistor GaAs devices - Familiarization of RF Field Effect Transistors and High Electron Mobility Transistors – Constructional details, RF circuit measurements and characterization - Using Vector Network analyzer - S parameter, Reflection Coefficient and Insertion loss Measurement, Modelling and Simulation of RF circuits using- Opensource/Commercial EM simulation software	10
IV	Amplifier design using S-parameters- Characteristics of Amplifier Power Relations Stability Considerations – Stability Circles, Tests for Unconditional Stability, High frequency amplifier design– Single stage amplifier Design –Design for maximum gain, Low noise amplifier design	9
V	Basic oscillator model-Feedback oscillator design-Negative Resistance Oscillator, Dielectric Resonator Oscillator- YIG Tuned Oscillator, Mixer- Basic characteristics - Single-Ended Mixer Design Single-balanced and double- balanced mixers	8
	Total hours	45

**vii) ASSESSMENT PATTERN****Mark distribution**

Total Marks	Continuous Internal Evaluation Marks	End Semester Evaluation Marks	End Semester Examination Duration
150	50	100	3 Hours

Continuous Internal Evaluation Pattern:

Attendance	10 Marks
Continuous Assessment Tests (2 numbers)	25 Marks
Assignment/Quiz/Course project	15 Marks

End Semester Examination Pattern:

There will be two parts; Part A and Part B. Part A contain 10 questions with 2 questions from each module, having 3 marks for each question. Students should answer all questions. Part B contains 2 questions from each module of which student should answer any one. Each question can have maximum 2 sub-divisions and carry 14 marks.



Course Code	Course Name	Category	L	T	P	Credit	Year of Introduction
EC1U42F	MIXED SIGNAL CIRCUIT DESIGN	PEC	2	1	0	3	2020

i) **PRE-REQUISITE:** EC1U20D ANALOG CIRCUITS, EC1U20B LOGIC CIRCUIT DESIGN

ii) **COURSE OVERVIEW:**

Goal of this course is to give the knowledge about various analog and digital CMOS circuits and to impart the skill in analysis and design of analog and digital CMOS circuits.

iii) **COURSE OUTCOMES**

After the completion of the course, the student will be able to:

Course Outcomes	Description	Level
CO 1	Analyse various analog and digital CMOS subcircuits	Understand
CO 2	Analyse various CMOS amplifiers.	Understand
CO 3	Analyse Data Converters.	Understand

iv) **SYLLABUS**

CMOS Amplifiers Active load: MOS resistor, MOS current source, diode connected MOS. **CMOS Amplifiers:** Common source amplifier with resistive and active loads, Common source amplifier with source degeneration, Common gate and Common drain amplifier (only voltage gain and input and output impedances of the circuits).

CMOS Differential Amplifiers MOS Current Mirror: Simple, Cascode and Wilson current mirror circuits. **CMOS Differential Amplifier:** Differential Amplifier with resistive, current source, with current mirror and cascode loads(only voltage gain and input and output impedance of the circuits).

CMOS Operational Amplifier Opamp Performance parameters, Single stage and two stage op-amps with different types of load. Gain Boosting in Opamp.

References and Switched Capacitor Circuits References: Supply Independent Biasing, Temperature independent references– band gap reference. Switched Capacitor Circuits: Switched capacitor resistor, Switched Capacitor Integrator, 1st order filter.

Data Converters DAC: Non-idealities in DAC, Types: Resistive, Charge redistribution, Voltage Scaling, Cyclic and Pipelined

ADC: Non-idealities in ADC, Sample and Hold circuit, quantization errors, Types of ADC : Flash, two step, pipelined, successive approximation, Folding.

v) (a) **TEXT BOOKS**

- 1) Behzad Razavi, “Design of Analog CMOS Integrated Circuits”, McGraw-Hill, 2/e, 2002
- 2) Meyer Gray , Hurst, Lewis, “Analysis and Design of Analog Integrated Circuits”, 5th Edition ,Wiley 2009.

**(b) OTHER REFERENCES**

- 1) Phillip E. Allen, Douglas R. Holbery, CMOS Analog Circuit Design, Oxford, 2004.
- 2) Razavi B., Fundamentals of Microelectronics, Wiley student Edition 2014.
- 3) Baker, Li, Boyce, CMOS: Circuits Design, Layout and Simulation, PHI, 2000.

vi) COURSE PLAN

Module	Contents	No. of hours
I	CMOS Amplifiers Active load: MOS resistor, MOS current source, diode connected MOS. CMOS Amplifiers: Common source amplifier with resistive and active loads, Common source amplifier with source degeneration, Common gate and Common drain amplifier (only voltage gain and input and output impedances of the circuits).	9
II	CMOS Differential Amplifiers MOS Current Mirror: Simple, Cascode and Wilson current mirror circuits. CMOS Differential Amplifier: Differential Amplifier with resistive, current source, with current mirror and cascode loads(only voltage gain and input and output impedance of the circuits)	9
III	CMOS Operational Amplifier Opamp Performance parameters, Single stage and two stage op-amps with different types of load. Gain Boosting in Opamp	9
IV	References and Switched Capacitor Circuits References: Supply Independent Biasing, Temperature independent references– band gap reference. Switched Capacitor Circuits: Switched capacitor resistor, Switched Capacitor Integrator, 1st order filter.	9
V	Data Converters DAC: Non-idealities in DAC, Types: Resistive, Charge redistribution, Voltage Scaling, Cyclic and Pipelined. ADC: Non-idealities in ADC, Sample and Hold circuit, quantization errors, Types of ADC : Flash, two step, pipelined, successive approximation, Folding.	9
	Total hours	45

**vii) ASSESSMENT PATTERN****Mark distribution**

Total Marks	Continuous Internal Evaluation Marks	End Semester Evaluation Marks	End Semester Examination Duration
150	50	100	3 Hours

Continuous Internal Evaluation Pattern:

Attendance	10 Marks
Continuous Assessment Tests (2 numbers)	25 Marks
Assignment/Quiz/Course project	15 Marks

End Semester Examination Pattern:

There will be two parts; Part A and Part B. Part A contain 10 questions with 2 questions from each module, having 3 marks for each question. Students should answer all questions. Part B contains 2 questions from each module of which student should answer any one. Each question can have maximum 2 sub-divisions and carry 14 marks.



Course Code	Course Name	Category	L	T	P	Credit	Year of Introduction
EC1U42G	ENTREPRENEURSHIP	PEC	3	0	0	3	2020

i) **PREREQUISITE:** Students should have a basic knowledge in management

ii) **COURSE OVERVIEW**

To understand the knowledge of entrepreneurship and apply in the organization.

iii) **COURSE OUTCOMES**

After the completion of the course the student will be able to:

Course Outcomes	Description	Level
CO 1	Discuss the fundamental concepts of entrepreneurship	Understand
CO 2	Explain entrepreneurial motivation and motivation theories	Understand
CO 3	Discuss types of enterprises and ownership structure	Understand
CO 4	Explain the various institutional support and policies offered for entrepreneurship development	Understand
CO 5	Apply project evaluation methods	Apply

iv) **SYLLABUS**

Entrepreneurship: definition, requirements to be an entrepreneur, entrepreneur and intrapreneur, women entrepreneurship, rural and urban entrepreneurship. Entrepreneurial Motivation: Maslow's need hierarchy theory, McClelland's acquired need theory.

Types of Enterprises: Small, medium and large-scale enterprises, role of small enterprises in economic development; Types of ownership Structures: Proprietorship, partnership, limited liability s and co-operatives: their formation, capital structure and source of finance.

Institutional Support and Policies: institutional support towards the development of entrepreneurship in India, technical consultancy organizations, Government programs, policies

Project identification and selection, project report, contents and formulation, elements of project formulation, project design and network analysis. Project evaluation methods internal rate of return method and net present value method.

Management of Enterprises: introduction to human resource management: planning, job analysis, Enterprise financing, raising and managing capital, shares, debentures, bonds, cost of capital; break-even analysis, balance sheet analysis.

v) (a) **TEXT BOOKS**

1. Khanka S S Entrepreneurial Development, S Chand & Company Ltd. New Delhi,2011
2. Ram Chandran, Entrepreneurial Development, Tata McGraw Hill, New Delhi, 2008
3. Saini, J. S. Entrepreneurial Development Programmes and Practices, Deep & Deep Publications,2012

**(b) REFERENCES**

1. Badhai, B Entrepreneurship for Engineers, B. K. Publications Private Limited, 2019
2. Desai, Vasant, Project Management and Entrepreneurship Himalayan Publishing Mumbai, 2017
3. Gupta, Srinivasan, 'Entrepreneurial Development', S Chand & Sons, New Delhi, 2020

vi) COURSE PLAN

Module	Contents	No. of hours
I	Entrepreneurship: definition, requirements to be an entrepreneur, entrepreneur and intrapreneur, entrepreneur and manager, growth of entrepreneurship in India, women entrepreneurship, rural and urban entrepreneurship. Entrepreneurial Motivation: motivating factors, motivation theories- Maslow's need hierarchy theory, McClelland's acquired need theory, government's policy actions towards entrepreneurial motivation, entrepreneurship development programmes.	9
II	Types of Enterprises: Small-scale, medium-scale and large-scale enterprises, role of small enterprises in economic development; Types of ownership Structures: Proprietorship, partnership, limited liability companies and co-operatives: their formation, capital structure and source of finance.	9
III	Institutional Support and Policies: institutional support towards the development of entrepreneurship in India, technical consultancy organizations, Government programs, policies, incentive and institutional networking for enterprise setting, women entrepreneurship development in India, promotional schemes.	9
IV	Project identification and selection: Identification and Selection process of projects, project report, contents and formulation, elements of project formulation, project design and network analysis Project evaluation: Concept of project evaluation, methods of project evaluation: internal rate of return method and net present value method.	9
V	Management of Enterprises: Objectives and functions of management, scientific management, general and strategic management; introduction to human resource management: planning, job analysis, training, recruitment and selection, marketing and organizational dimension of enterprises; enterprise financing, raising and managing capital, shares, debentures, bonds, cost of capital; break-even analysis, balance sheet analysis.	9
	Total hours	45

**vii) ASSESSMENT PATTERN****Mark distribution**

Total Marks	Continuous Internal Evaluation Marks	End Semester Evaluation Marks	End Semester Examination Duration
150	50	100	3 Hours

Continuous Internal Evaluation Pattern:

Attendance	10 Marks
Continuous Assessment Tests (2 numbers)	25 Marks
Assignment/Quiz/Course project	15 Marks

End Semester Examination Pattern:

There will be two parts; Part A and Part B. Part A contain 10 questions with 2 questions from each module, having 3 marks for each question. Students should answer all questions. Part B contains 2 questions from each module of which student should answer any one. Each question can have maximum 2 sub-divisions and carry 14 marks.



PROGRAMME ELECTIVE-IV

Course Code	Course Name	Category	L	T	P	Credit	Year of Introduction
EC1U43A	MODERN COMMUNICATION SYSTEMS	PEC	3	0	0	3	2020

- i) **PRE-REQUISITE:** MA0U20C -Probability, Random Process and Numerical Methods, EC1U30C - Analog and Digital Communication, EC1U30G -Information Theory and Coding
- ii) **COURSE OVERVIEW:** This course aims to impart knowledge on the basics of modern communication systems and the breakthrough wireless technologies.

iii) COURSE OUTCOMES

After the completion of the course, the student will be able to:

Course Outcomes	Description	Level
CO 1	Explain OFDM, OFDMA and SC-FDMA techniques used in cellular communication	Apply
CO 2	Discuss the different wireless communication standards for short range communication	Understand
CO 3	Explain the IoT architecture and various connectivity technologies used in IoT Systems	Understand
CO 4	Explain various communication standards for connected autonomous vehicles .	Understand
CO 5	Explain the significance and architecture of software defined radio and cognitive radio.	Understand

iv) SYLLABUS

Cellular Communication System

Need for Multi carrier system, Basics of Orthogonal Frequency Division Multiplexing (OFDM), Multiple access for OFDM systems, Orthogonal Frequency Division Multiple Access (OFDMA), Single carrier Frequency Division Multiple Access (SC-FDMA). Cellular concept, path loss and shadowing, Doppler shift, Multipath effect, Significance of diversity in wireless communication systems.

Short Range Communication System

Introduction to current wireless technologies, background and current scenario, future wireless network requirements, IEEE 802.11 (Wi-Fi) standards and applications (IEEE 802.11a/b/g/n/ac/ax), HiperLAN technology, WPAN (IEEE 802.15.1, IEEE 802.15.3 & IEEE 802.15.4) and WMAN (IEEE 802.16a - WiMAX), Space time wireless standards, IEEE 802.16 (Wi-Max standard), 3GPP-LTE standard, Millimeter wave characteristics, Channel performance at 60 GHz, Development of millimeter wave standards, Indoor and outdoor applications for millimeter wave communications. 6G Networks – Use Cases and Technologies.



IoT System

Introduction of IoT, characteristics, physical and logical design of IoT, IoT Enabling Technologies – Wireless Sensor networks, Cloud computing. Introduction to IoT, Evolution of IoT, IoT Networking Components. IoT Connectivity Technologies – Zigbee, Wireless HART, RFID, NFC, LoRa, WiFi, Bluetooth. IoT Communication Technologies – Infrastructure Protocols – IPv6, 6LoWPAN, Data Protocols – MQTT, MQTT-SN, CoAP. IoT Case Studies and Future Trends – Agricultural IoT, Vehicular IoT, Healthcare IoT.

Intelligent Transport System

Introduction to Intelligent Vehicular Communication – Evolution, Vehicular Networks and ITS, Vehicular Communication Standards/ Technologies – DSRC, IEEE 802.11p WAVE, IEEE 1609, IEEE 802.15.7 - Visible Light Communication (VLC), 4G/5G-Device to Device (D2D), 6G Cellular Networks and Connected Autonomous Vehicles, Operational Scenario – Collision Avoidance.

Software Defined Radio System

Software radio concepts, Operating frequency bands, Transmitter and Receiver specifications of SDR, Architecture of SDR, Introduction of cognitive radio, significance of cognitive radio and spectrum subleasing, spectrum sharing in cognitive radio, implementation of cognitive radio.

v) (a) TEXT BOOKS

1. Aditya K. Jagannatham, “Principles of Modern Wireless Communication Systems”, Tata McGraw Hill, 2016.
2. T.L. Singal, “Wireless Communications”, Tata McGraw Hill Education Private Limited, Second Edition, 2011.
3. K. C. Huang, Z. Wang, “Millimeter Wave Communication systems”, John Wiley & Sons.
4. Sudip Misra, Anandarup Mukherjee & Arijit Roy. “Introduction to IoT”. Cambridge University Press. 2021.
5. George J. Dimitrakopoulos. “Current Technologies in Vehicular Communication”, Springer International Publishing, 2017.
6. He, J., Yang, K. and Chen, H.H, “6G Cellular Networks and Connected Autonomous Vehicles”, IEEE Network, vol. 35, no. 4, pp. 255 -261, 2020.
7. Walter Tuttlebee, “SDR Enabling Technologies”, John Wiley.
8. Huseyin Arslan, “Cognitive Radio, SDR and Adaptive Wireless System”, Springer, 2007.

b) REFERENCES

1. Dipankar Raychaudhuri, Mario Gerla, “Emerging Wireless Technologies and the Future Mobile Internet”, Cambridge University Press, 2011.
2. Arshdeep Bahga, A., & Vijay Madisetti V. “Internet of Things: A hands-on approach”. Vpt., 2014.
3. Paul, A., Chilamkurti, N., Daniel, A. and Rho, S. “Intelligent vehicular networks and communications: fundamentals, architectures and solutions”. Elsevier, 2016.
4. Peter B. Kenington, ‘RF and baseband techniques for software defined radio’, Artech House Mobile Communication, 2005.



vi) COURSE PLAN

Module	Contents	No. of hours
I	Need for Multi carrier system, Basics of Orthogonal Frequency Division Multiplexing (OFDM), Multiple access for OFDM systems, Orthogonal Frequency Division Multiple Access (OFDMA), Single carrier Frequency Division Multiple Access (SC-FDMA). Cellular concept, path loss and shadowing, Doppler shift, Multipath effect, Significance of diversity in wireless communication systems.	9
II	Introduction to current wireless technologies, background and current scenario, future wireless network requirements, IEEE 802.11 (Wi-Fi) standards and applications (IEEE 802.11a/b/g/n/ac/ax), HiperLAN technology, WPAN (IEEE 802.15.1, IEEE 802.15.3 & IEEE 802.15.4) and WMAN (IEEE 802.16a - WiMAX), Space time wireless standards, IEEE 802.16 (Wi-Max standard), 3GPP-LTE standard, Millimeter wave characteristics, Channel performance at 60 GHz, Development of millimeter wave standards, Indoor and outdoor applications for millimeter wave communications. 6G Networks – Use Cases and Technologies.	10
III	Introduction of IoT, characteristics, physical and logical design of IoT, IoT Enabling Technologies – Wireless Sensor networks, Cloud computing. Introduction to IoT, Evolution of IoT, IoT Networking Components. IoT Connectivity Technologies – Zigbee, Wireless HART, RFID, NFC, LoRa, WiFi, Bluetooth. IoT Communication Technologies – Infrastructure Protocols – IPv6, 6LoWPAN, Data Protocols – MQTT, MQTT-SN, CoAP. IoT Case Studies and Future Trends – Agricultural IoT, Vehicular IoT, Healthcare IoT.	8
IV	Introduction to Intelligent Vehicular Communication – Evolution, Vehicular Networks and ITS, Vehicular Communication Standards/ Technologies – DSRC, IEEE 802.11p WAVE, IEEE 1609, IEEE 802.15.7 - Visible Light Communication (VLC), 4G/5G-Device to Device (D2D), 6G Cellular Networks and Connected Autonomous Vehicles, Operational Scenario – Collision Avoidance.	8
V	Software radio concepts, Operating frequency bands, Transmitter and Receiver specifications of SDR, Architecture of SDR, Introduction of cognitive radio, significance of cognitive radio and spectrum subleasing, spectrum sharing in cognitive radio, implementation of cognitive radio.	10
	Total hours	45

**vii) ASSESSMENT PATTERN****Mark distribution**

Total Marks	Continuous Internal Evaluation Marks	End Semester Evaluation Marks	End Semester Examination Duration
150	50	100	3 Hours

Continuous Internal Evaluation Pattern:

Attendance	10 Marks
Continuous Assessment Tests (2 numbers)	25 Marks
Assignment/Quiz/Course project	15 Marks

End Semester Examination Pattern:

There will be two parts; Part A and Part B. Part A contain 10 questions with 2 questions from each module, having 3 marks for each question. Students should answer all questions. Part B contains 2 questions from each module of which student should answer any one. Each question can have maximum 2 sub-divisions and carry 14 marks.



Course Code	Course Name	Category	L	T	P	Credit	Year of Introduction
EC1U43B	REAL TIME OPERATING SYSTEMS	PEC	2	1	0	3	2020

i) **PREREQUISITE:** Students should have a basic knowledge in Computer Architecture and Microcontrollers

ii) COURSE OVERVIEW

To understand RTOS, its basic structure, building blocks, various operations and to summarize the different scheduling algorithms used in RTOS.

iii) COURSE OUTCOMES

After the completion of the course the student will be able to:

Course Outcomes	Description	Level
CO 1	Summarize the functions and structure of general-purpose operating systems.	Understand
CO 2	Use different scheduling algorithms on processes and threads.	Apply
CO 3	Interpret a real time operating system along with its synchronization, communication and interrupt handling tools.	Understand
CO 4	Illustrate task constraints and analyze the different scheduling algorithms on tasks.	Analyse
CO 5	Illustrate the applications of real time operating systems.	Apply

iv) SYLLABUS

Operating system: Types, Objectives and functions, Kernel, Process - States, Process Control Block, Operations on processes

Process Scheduling: FCFS, SJF, Priority, Round-Robin, Multilevel Queue and Multilevel Feedback Queue Scheduling. Thread: Structure. User and kernel level threads, multi-threading models, multiprocessor scheduling

Real Time Operating Systems: Structure and characteristics of Real Time Systems, Task: Task states, Task synchronization -Semaphores- types, Inter task communication mechanisms: message queues, pipes, event registers, signals, Exceptions and interrupt handling.

Task constraints, Task scheduling: Aperiodic task scheduling: EDD, EDF, LDF, EDF with precedence constraints. Periodic task scheduling: Rate monotonic and Deadline monotonic, Real time Kernel-Structure, State transition diagram, Kernel primitives.

Features of FreeRTOS and Linux Commercial real time operating systems: PSOS, VRTX, RT Linux Features and application only. Case study of (Kernel design, threads and task scheduling) RTOS: MicroC/OS-II. RTOS control system used in real life applications - in adaptive cruise control.

**v) (a) TEXT BOOKS**

1. Abraham Silberschatz- ‘Operating System Principles’: Wiley India,7th edition, 2011
2. William Stallings –‘Operating systems- Internals and design principles’, Prentice Hall, 7th edition, 2011
3. Qing Li – ‘Real-Time Concepts for Embedded Systems ‘, CMP Books, 2013
4. Giorgio C. Buttazzo, -‘HARD REAL-TIME COMPUTING SYSTEMS Predictable Scheduling Algorithms and Applications’, Kluwer Academic Publishers.

(b) REFERENCES

1. Tanenbaum -‘Modern Operating Systems’ ,Pearson Edition, 3/e, 2007.
2. Jean J Labrosse , ‘Micro C/OS-II, The Real Time Kernel’ , CMP Books, 2011
3. Rajib Mall, ‘Real-Time Systems: Theory and Practice ‘ , 2008.
4. David E. Simon ‘An Embedded Software Primer’, Pearson 2012
5. Raj Kamal, ‘Embedded Systems – Architecture, Programming and Design’,Tata McGraw Hill

vi) COURSE PLAN

Module	Contents	No. of hours
I	Operating system: Types, Objectives and functions, Kernel, Process - States, Process Control Block, Operations on processes.	9
II	Process Scheduling: FCFS, SJF, Priority, Round-Robin, Multilevel Queue and Multilevel Feedback Queue Scheduling. Thread: Structure. User and kernel level threads, multi-threading models, multiprocessor scheduling	9
III	Real Time Operating Systems: Structure and characteristics of Real Time Systems, Task: Task states, Task synchronization - Semaphores- types, Inter task communication mechanisms: message queues, pipes, event registers, signals, Exceptions and interrupt handling.	9
IV	Task constraints, Task scheduling: Aperiodic task scheduling: EDD. EDF, LDF, EDF with precedence constraints. Periodic task scheduling:Rate monotonic and Deadline monotonic, Real time Kernel- Structure, State transition diagram, Kernel primitives.	9
V	Features of FreeRTOS and Linux Commercial real time operating systems: PSOS, VRTX, RT Linux Features and application only. Case study of (Kernel design, threads and task scheduling) RTOS: MicroC/OS-II. RTOS control system used in real life applications - in adaptive cruise control.	9
	Total hours	45

**vii) ASSESSMENT PATTERN****Mark distribution**

Total Marks	Continuous Internal Evaluation Marks	End Semester Evaluation Marks	End Semester Examination Duration
150	50	100	3 Hours

Continuous Internal Evaluation Pattern:

Attendance	10 Marks
Continuous Assessment Tests (2 numbers)	25 Marks
Assignment/Quiz/Course project	15 Marks

End Semester Examination Pattern:

There will be two parts; Part A and Part B. Part A contain 10 questions with 2 questions from each module, having 3 marks for each question. Students should answer all questions. Part B contains 2 questions from each module of which student should answer any one. Each question can have maximum 2 sub-divisions and carry 14 marks.



Course Code	Course Name	Category	L	T	P	Credit	Year of Introduction
EC1U43C	ADAPTIVE SIGNAL PROCESSING	PEC	2	1	0	3	2020

i) **PREREQUISITE:** EC1U30B - Digital Signal processing

ii) **COURSE OVERVIEW:**

This course aims to introduce to the concept and need of adaptive filters and popular adaptive signal processing algorithms.

iii) **COURSE OUTCOMES**

After the completion of the course, the student will be able to:

Course Outcomes	Description	Level
CO 1	Explain the basic concepts of statistical signal processing.	Understand
CO 2	Design filters for optimising the cost function indicating error in estimation of parameters and appreciate the need for adaptation in design.	Apply
CO 3	Evaluate the performance of various methods for designing adaptive filters through estimation of different parameters of stationary random process clearly considering practical application specifications.	Apply
CO 4	Analyse convergence and stability issues associated with adaptive filter design and come up with optimum solutions for real life applications taking care of requirements in terms of complexity and accuracy	Apply
CO 5	Design and implement filtering solutions for applications such as channel equalisation, interference cancelling and prediction considering present day challenges	Apply

iv) **SYLLABUS**

Basics of adaptive systems, applications, different performance functions, searching performance surface-stability and rate of convergence, LMS/Newton algorithm, adaptive recursive filters, Kalman filters, Applications-adaptive modelling and system identification: Multipath communication channel, geophysical exploration, Kalman filter as the unifying basis for RLS filters, Inverse adaptive modelling

v) a) **TEXT BOOKS**

- 1) Bernard Widrow and Samuel D. Stearns, —Adaptive Signal Processing, Person Education, 1985
- 2) Mons H Hays -Statistical Digital Signal Processing and Modeling -Wiley Publications, 2006

b) **REFERENCES**

- 1) Simon Haykin, —Adaptive Filter Theory, Pearson Education, 2003.
- 2) John R. Treichler, C. Richard Johnson, Michael G. Larimore, —Theory and Design of Adaptive Filters, Prentice-Hall of India, 2002.



- 3) John G. Proakis, Dimitris G. Manolokis, “Digital Signal Processing”, Prentice Hall of India, New Delhi, 2005
- 4) S. Thomas Alexander, “Adaptive Signal Processing - Theory and Application”, Springer Verlag.
- 5) D. G. Manolokis, V. K. Ingle and S. M. Kogar, “Statistical and Adaptive Signal Processing”, McGraw Hill International Edition, 2000.

vi) COURSE PLAN

Module	Contents	No. of hours
I	Adaptive systems- Definitions and characteristics - applications – properties examples - adaptive linear combiner input signal and weight vectors - performance function-gradient and minimum mean square error - introduction to filtering- smoothing and prediction - linear optimum filtering-orthogonality - Wiener – Hopf equation performance surface	10
II	Searching performance surface-stability and rate of convergence: Learning curve gradient search - Newton's method - method of steepest descent - comparison - Gradient estimation - performance penalty - variance - excess MSE and time constants – mis adjustments	9
III	LMS algorithm, convergence of weight vector: LMS/Newton algorithm - properties - sequential regression algorithm - adaptive recursive filters - random-search algorithms - lattice structure - adaptive filters with orthogonal signals.	9
IV	Kalman filters-recursive minimum mean square estimation for scalar random variable. Applications-adaptive modeling and system identification: Multipath communication channel, geophysical exploration, Kalman filter as the unifying basis for RLS filters.	9
V	Inverse adaptive modeling: Equalization, and deconvolution adaptive equalization of telephone channels-adapting poles and zeros for IIR digital filter synthesis	8
	Total hours	45

**vii) ASSESSMENT PATTERN****Mark distribution**

Total Marks	Continuous Internal Evaluation Marks	End Semester Evaluation Marks	End Semester Examination Duration
150	50	100	3 Hours

Continuous Internal Evaluation Pattern:

Attendance	10 Marks
Continuous Assessment Tests (2 numbers)	25 Marks
Assignment/Quiz/Course project	15 Marks

End Semester Examination Pattern:

There will be two parts; Part A and Part B. Part A contain 10 questions with 2 questions from each module, having 3 marks for each question. Students should answer all questions. Part B contains 2 questions from each module of which student should answer any one. Each question can have maximum 2 sub-divisions and carry 14 marks.



Course Code	Course Name	Category	L	T	P	Credit	Year of Introduction
EC1U43D	MICROWAVE DEVICES AND CIRCUITS	PEC	3	0	0	3	2020

i) **PREREQUISITE:** Nil

ii) **COURSE OBJECTIVES**

- To study microwave semiconductor devices & applications.
- To study microwave sources and amplifiers.
- To analyse microwave networks.
- To introduce microwave integrated circuits

iii) **COURSE OVERVIEW**

This goal of this course is to understand with active and passive microwave semiconductor devices, components, microwave sources and amplifiers used in microwave communication systems, analysis of microwave networks and microwave integrated circuits.

iv) **COURSE OUTCOMES**

After the completion of the course, the student will be able to

Course Outcomes	Description	Level
CO 1	Understand the limitation of conventional solid state devices at Microwave, Gunn – effect diodes, Microwave generation and amplification, IMPATT and TRAPATT diodes	Understand
CO 2	Design of Bipolar transistors, MESFET, Microwave amplifiers and oscillator	Apply
CO 3	Analysis of Microwave Network Analysis and the corresponding signal flow graphs	Apply
CO 4	Design of Microwave filters, Filter design by image parameter method, Filter transformation and implementation	Apply
CO 5	Understand different MICs, Distributed and lumped elements of integrated circuits, Diode control devices.	Understand

v) **SYLLABUS**

Introduction, Characteristic, features of microwaves, Gunn diodes, Bipolar transistors, FET, MESFET Microwave amplifiers and oscillators, Microwave Network Analysis, Impedance matching and tuning. Microwave filters, Filter design by image parameter method, Filter transformation and implementation, Introduction to MICs, Distributed and lumped elements of integrated circuits, Diode control devices.

**vi)a) TEXT BOOKS:**

1. David M. Pozar, Microwave Engineering, 4/e, Wiley India, 2012.
2. Robert E. Collin, Foundation of Microwave Engineering, 2/e, Wiley India, 2012.
3. Samuel Y. Liao, Microwave Devices and Circuits, 3/e, Pearson Education, 2003.

b) REFERENCES:

1. Bharathi Bhat and Shiban K. Koul: Stripline-like Transmission Lines for MIC, New Age International (P) Ltd, 1989.
2. I. Kneppo, J. Fabian, et al., Microwave Integrated Circuits, BSP, India, 2006.
3. Leo Maloratsky, Passive RF and Microwave Integrated Circuits, Elsevier, 2006.

vii) COURSE PLAN

Module	Contents	No. of hours
I	Introduction, Characteristic, features of microwaves, Limitation of conventional solid state devices at Microwave Gunn – effect diodes – Gunn effect, Ridley – Watkins-Hilsum theory, Modes of operation, Limited space – Charge accumulation (LSA) mode of Gunn diode. Microwave generation and amplification. Structure, Operation, Power output and efficiency of IMPATT and TRAPATT diodes	9
II	Bipolar transistors – biasing, FET – biasing, MESFET – Structure, Operation. Microwave amplifiers and oscillators – Amplifiers – Gain and stability, Single stage transistor amplifier design Oscillator design – One port negative resistance oscillators.	9
III	Microwave Network Analysis – Equivalent voltages and currents, Impedance and Admittance matrices, Scattering matrix, The transmission matrix Signal flow graphs. Impedance matching and tuning – Matching with lumped elements, Single stub tuning, Double stub tuning. Quarter wave transformer, Theory of small reflections	9
IV	Microwave filters, Periodic structures, Analysis of periodic structures Filter design by image parameter method – Constant k, m-derived and composite. Filter design by insertion loss method. Filter transformation and implementation	9
V	Introduction to MICs:-Technology of hybrid MICs, monolithic MICs. Comparison of both MICs. Planar transmission lines such as stripline, microstrip line, and slotline Distributed and lumped elements of integrated circuits - capacitors, inductors, resistors, terminations, attenuators, resonators and discontinuities Diode control devices – switches, attenuators, limiters. Diode phase shifter. Circulators and isolators.	9
	Total hours	45

**viii) ASSESSMENT PATTERN****Mark distribution**

Total Marks	Continuous Internal Evaluation Marks	End Semester Evaluation Marks	End Semester Examination Duration
150	50	100	3 Hours

Continuous Internal Evaluation Pattern:

Attendance	10 Marks
Continuous Assessment Tests (2 numbers)	25 Marks
Assignment/Quiz/Course project	15 Marks

End Semester Examination Pattern:

There will be two parts; Part A and Part B. Part A contain 10 questions with 2 questions from each module, having 3 marks for each question. Students should answer all questions. Part B contains 2 questions from each module of which student should answer any one. Each question can have maximum 2 sub-divisions and carry 14 marks.



Course Code	Course Name	Category	L	T	P	Credit	Year of Introduction
EC1U43E	SPEECH & AUDIO PROCESSING	PEC	3	0	0	3	2020

i) COURSE OVERVIEW

This course introduces students to the mechanism of speech production and the basic concepts of methods for speech analysis and parametric representation of speech. The course imparts ideas related to perception of sound, psycho-acoustic analysis, spatial audio perception and rendering and introduces audio compression schemes to the students.

ii) COURSE OUTCOMES

After the completion of the course, the student will be able to:

Course Outcomes	Description	Level
CO 1	Discuss the basic concepts of speech production, speech analysis, speech coding and parametric representation of speech	Understand
CO 2	Describe frequency domain analysis of speech and various applications of speech processing.	Understand
CO 3	Discuss signal processing models of sound perception and the application of perception models in audio signal processing	Understand
CO 4	Describe audio compression algorithms and standards	Understand
CO 5	Describe the concept of Spatial Audio Perception and audio quality analysis techniques	Understand

iii) SYLLABUS

Speech Production: Acoustic theory of speech production. Speech Analysis: Speech signal, Short-Time Speech Analysis, Time domain analysis (Short time energy, short time zero crossing Rate, ACF).LPC Analysis (LPC model, Auto correlation method).

Frequency domain analysis (Filter Banks, STFT, Spectrogram), Cepstral Analysis, MFCC. Probabilistic formulation of speech recognition, Speech coding: fundamentals, Comparison of waveform coding, vocoding and hybrid coding, Speech enhancement: fundamentals, basic types, Speaker verification (block diagram), Language Identification (block diagram)



Signal Processing Models of Audio Perception: Basic anatomy of hearing System. Auditory Filter Banks, Psycho-acoustic analysis: Critical Band Structure, Absolute Threshold of Hearing, Simultaneous Masking, Temporal Masking, MPEG psycho-acoustic model.

Audio compression methods: Sampling rate and bandwidth requirement for digital audio, Redundancy removal and perceptual irrelevancy removal, Transform coding of digital audio: MPEG2-AAC coding standard, MDCT and its properties, Pre-echo and pre-echo suppression, Loss less coding methods.

Spatial Audio Perception and rendering: The physical and psycho- acoustical basis of sound localization and space perception. Spatial audio standards. Audio quality analysis: Objective analysis methods- PEAQ, Subjective analysis methods - MOS score, MUSHRA score

iv) a) TEXT BOOKS

- 1) W. Fischer, Digital Video and Audio Broadcasting Technology: A Practical Engineering Guide (Signals and Communication Technology), Springer, 2020
- 2) Lars-Ingemar Lundström, Understanding Digital Television: An Introduction to DVB Systems with Satellite, Cable, Broadband and Terrestrial TV, Focal Press, Elsevier, 2006.
- 3) K F Ibrahim, Newnes Guide to Televeision and Video Technology, Newnes, 2007.
- 4) Jiun-Haw Lee, David N. Liu, Shin-Tson Wu, Introduction to Flat Panel Displays, Wiley, 2008.

b) REFERENCES

- 1) C. Poynton, "Digital Video and HD Algorithms and Interfaces,"Morgan Kaufmann, 2012.
- 2) Wolfgang Hoeg, Thomas Lauterbach, Digital audio broadcasting: principles and applications of DAB, DAB+ and DMB, Wiley, 2009.
- 3) John Watkinson, Introduction to Digital Audio, Focal Press, 1994.
- 4) John Watkinson, Art of Digital Video, Focal Press, 2008.
- 5) John Watkinson, Introduction to Digital Video, Focal Press, 2001.

v) COURSE PLAN

Module	Contents	No. of hours
I	Acoustic theory of speech production, Speech signal, Short-time analysis of speech, Time domain analysis (Short time energy, short time zero crossing Rate, ACF), LPC Analysis	9
II	Frequency domain analysis (Filter Banks, STFT, Spectrogram), Cepstral Analysis, MFCC, Fundamentals of Speech recognition, Speech coding, Speech Enhancement, Speaker Verification, Language Identification	9
III	Signal Processing Models of Audio Perception, Basic anatomy of hearing System. Auditory Filter Banks, Psycho-acoustic analysis. Critical Band	9



	Structure, Absolute Threshold of Hearing. Simultaneous Masking, Temporal Masking, MPEG psycho-acoustic model	
IV	Sampling rate and bandwidth requirement for digital audio, Redundancy removal and perceptual irrelevancy removal, Transform coding of digital audio: MPEG2-AAC coding standard, MDCT and its properties, Pre-echo and pre-echo suppression, Lossless coding methods.	9
V	Spatial Audio Perception and rendering, The physical and psycho-acoustical basis of sound localization and space perception. Spatial audio standards. Audio quality analysis: Objective analysis methods- PEAQ, Subjective analysis methods - MOS score, MUSHRA score	9
	tal hours	45

vi) ASSESSMENT PATTERN

Mark distribution

Total Marks	Continuous Internal Evaluation Marks	End Semester Evaluation Marks	End Semester Examination Duration
150	50	100	3 Hours

Continuous Internal Evaluation Pattern:

Attendance	10 Marks
Continuous Assessment Tests (2 numbers)	25 Marks
Assignment/Quiz/Course project	15 Marks

End Semester Examination Pattern:

There will be two parts; Part A and Part B. Part A contain 10 questions with 2 questions from each module, having 3 marks for each question. Students should answer all questions. Part B contains 2 questions from each module of which student should answer any one. Each question can have maximum 2 sub-divisions and carry 14 marks.



Course Code	Course Name	Category	L	T	P	Credit	Year of Introduction
EC1U43F	ANALOG CMOS DESIGN	PEC	2	1	0	3	2020

i) **PREREQUISITE:** EC1U20D- Analog Circuits, EC1U20A-Solid State Devices

ii) **COURSE OVERVIEW**

This course aims to impart the basic knowledge of CMOS analog circuits design and enable the students to design integrated circuits.

iii) **COURSE OUTCOMES**

After the completion of the course, the student will be able to:

Course Outcomes	Description	Level
CO 1	Analyse various single stage amplifiers and differential amplifiers with different types of loads	Analyse
CO 2	Design various types of current mirrors	Apply
CO 3	Plot the frequency response of single stage and differential amplifiers	Understand
CO 4	Analyse the effect of noise in single stage amplifiers	Analyse
CO 5	Implement PLL for various applications	Understand

iii) **SYLLABUS**

Basic MOS Device physics- Review of MOS Characteristics and Second order effects(only basic theoretical concepts). Single Stage Amplifiers. Common Source Stage with Different Load types , Source Follower,Common Gate and Cascode Stage. Differential Amplifiers - Single-ended and differential operation, Basic differential pair, Common-mode response, Differential pair with MOS load, Gilbert Cell. Current Mirror: Simple, Cascode and Basic concepts of active current Mirror. Frequency Response of Amplifiers: Miller Effect, Poles and Zeros, Frequency Response Analysis of Common Source, Source Follower, Common Gate and Differential Pair. Noise in Amplifiers: Noise in Single Stage amplifier (CS,CG,Source Follower), Noise in Differential Pair, Noise Band Width. Phase Locked Loops- Mathematical model of VCO, Phase Detector, Basic PLL Topology,Type I and Type II(Charge Pump) PLL, Stability Analysis of PLL, Non Ideal Effects in PLL,Application of PLL- Frequency Multiplication, Frequency synthesizer and Skew reduction.Block Diagram of Digital PLL

iv)a) **TEXT BOOKS**



- 1) Behzad Razavi, “Design of Analog CMOS Integrated Circuits”, McGraw-Hill, 2/e,2002

REFERENCES

- 1) Phillip E. Allen, Douglas R. Holbery, CMOS Analog Circuit Design, Oxford, 2004.
- 2) Razavi B., Fundamentals of Microelectronics, Wiley student Edition 2014.
- 3) Baker, Li, Boyce, CMOS: Circuits Design, Layout and Simulation, PHI, 2000

v) COURSE PLAN

Module	Contents	No. of hours
I	Basic MOS Device physics- Review of MOS Characteristics and Second order effects(only basic theoretical concepts). Single Stage Amplifiers. Common Source Stage with Different Load types , Source Follower, Common Gate and Cascode Stage	9
II	Differential Amplifiers - Single-ended and differential operation, Basic differential pair, Common-mode response, Differential pair with MOS load, Gilbert Cell. Current Mirror: Simple, Cascode and Basic concepts of active current Mirror	9
III	Frequency Response of Amplifiers: Miller Effect, Poles and Zeros, Frequency Response Analysis of Common Source, Source Follower, Common Gate and Differential Pair	9
IV	Noise in Amplifiers: Noise in Single Stage amplifier (CS,CG,Source Follower), Noise in Differential Pair, Noise Band Width.	9
V	Phase Locked Loops- Mathematical model of VCO, Phase Detector, Basic PLL Topology, Type I and Type II(Charge Pump) PLL, Stability Analysis of PLL, Non Ideal Effects in PLL, Application of PLL- Frequency Multiplication, Frequency synthesizer and Skew reduction. Block Diagram of Digital PLL	9
	Total hours	45



vi) ASSESSMENT PATTERN

Mark distribution

Total Marks	Continuous Internal Evaluation Marks	End Semester Evaluation Marks	End Semester Examination Duration
150	50	100	3 Hours

Continuous Internal Evaluation Pattern:

Attendance	10 Marks
Continuous Assessment Tests (2 numbers)	25 Marks
Assignment/Quiz/Course project	15 Marks

End Semester Examination Pattern:

There will be two parts; Part A and Part B. Part A contain 10 questions with 2 questions from each module, having 3 marks for each question. Students should answer all questions. Part B contains 2 questions from each module of which student should answer any one. Each question can have maximum 2 sub-divisions and carry 14 marks.



Course Code	Course Name	Category	L	T	P	Credit	Year of Introduction
EC1U43G	ROBOTICS	PEC	3	0	0	3	2020

i) COURSE OVERVIEW

The goal of this course is to introduce to the students the emerging field of robotics by imparting the fundamental knowledge on the design and control of robots, their multi-disciplinary engineering aspects and applications.

ii) COURSE OUTCOMES

After the completion of the course, the student will be able to:

Course Outcomes	Description	Level
CO 1	Explain different types of Robots and its applications	Understand
CO 2	Select appropriate sensors and actuators based on the robotic applications	Understand
CO 3	Perform kinematic and dynamic analyses for robots.	Apply
CO 4	Carry out the design and control of a simple robot..	Apply
CO 5	Integrate mechanical and electrical hardware for making a robotic device	Apply

ii) SYLLABUS

Introduction to Robotics: Definition and Origin of Robotics.- Robot Anatomy. Robot Specifications. Robot Characteristics - Classification of Robots - Robot Structure - Common Kinematic Arrangements. Degree of Freedom. **Introduction to Sensors and Actuation Systems for Robots:** Actuators - Sensors- Robotic Vision System **Introduction to Robot Kinematics and Dynamics:** Introduction to Kinematics - Kinematic Modelling - Velocity Kinematics – Forward and Inverse Dynamics- Equations of Motion using Euler-Lagrange formulation, Newton Euler Formulation. **Introduction to Robot Control:** Basics of Control Open Loop- Closed Loop, Transfer Functions, Control Laws: P, PD, PID, Linear and Non-linear Controls; Control Hardware and Interfacing; Embedded Systems - Actuators, Introduction to Robot Programming **Recent Developments in Robotics. Mobile Robots:** Mobile Robot Kinematics, Navigation. Humanoid Robotics -. Collaborative Robots - Artificial Intelligence in Robotics: Industrial Applications of Robots in Material Handling and Assembly

iii) (a) TEXTBOOKS

1. S.K. Saha, Introduction to Robotics, Tata McGraw Hill, 2nd Edition, 2014



2. Saeed B. Niku, Introduction to Robotics: Analysis, Systems, Applications, John Wiley & Sons, 2nd Edition, 2011.
3. Spong and Vidyasagar, Robot Dynamics and Control, John Wiley & Sons, 1990.
4. Mikell P. Groover, et al., Industrial Robotics – Technology, Programming and Applications, McGraw Hill, 2nd Edition, 2012

(b) REFERENCES

1. John. J.Craig, Introduction to Robotics: Mechanics and Control, PHI, 2005.
2. Ashitava Ghosal, Robotics, Fundamental concepts and analysis, OXFORD University Press, 2006
3. Fu, K.S,Gonzalez,R.C, Lee, C.S.G.,Robotics, Control, Sensing, Vision and Intelligence, McGraw-Hill, 1987.
4. Asada, H., and J. J. Slotine. Robot Analysis and Control. New York, NY: Wiley, 1986.
5. Robert J. Schilling, Fundamentals of Robotics: Analysis & Control, Pearson Education, 2000
6. Klafter, R.D., Chmielewski, T.A, Negin, M, Robotic Engineering An Integrated Approach, PHI, 2007
7. S. R. Deb, Robotics Technology and Flexible Automation, Tata McGraw Hill, New Delhi, 1994.

iv) COURSE PLAN

Module	Contents	No. of hours
I	Introduction to Robotics: Definition and Origin of Robotics. robot Anatomy. Robot Specifications. Robot Characteristics – Accuracy, Precision, and Repeatability. Classification of Robots. Advantages and Disadvantages of Robots. Robot Structure - Types of Joints and End Effectors, Mechanisms and Manipulators. Common Kinematic Arrangements. Degree of Freedom. Robot Coordinates. Reference Frames. Robot Workspace. Areas of Application for Robots.	9
II	Introduction to Sensors and Actuation Systems for Robots: Actuators: Types of Robotic Drive Systems and Actuators: Hydraulic, Pneumatic and Electric drives. Transmission: Gears, Timing Belts and Bearings. Parameters for selection of actuators. Specification. Areas of Application for: Stepper Motor, Servo Motor and Brushless DC Motor. Microprocessor Control of Motors. Speed Control using PWM and Direction Control using H- Bridge. Sensors: Types and Applications of Sensors in Robotics: Position, Displacement and Velocity Sensors. Tactile Sensors for Contact and Proximity Assessment. Strain Gauge based Force and Torque Sensors. Tachometers, etc. Robotic Vision Systems- Introduction to Cameras, Imaging, Sensing and Digitization. Vision Applications in Robotics.	9



III	<p>Introduction to Robot Kinematics and Dynamics: Introduction to Kinematics: Position and Orientation of Objects. Rotation. Euler Angles. Rigid Motion Representation using Homogenous Transformation Matrix. Kinematic Modelling: Translation and Rotation Representation, Coordinate Transformation, Forward and Inverse Kinematics. Forward Kinematics-Link Coordinates, Denavit-Hartenberg Representation, Application of DH Convention to Different Serial Kinematic Arrangements. Inverse Kinematics – General Properties of Solutions, Kinematic Decoupling, Velocity Kinematics – Derivation of the Jacobian, Application of Velocity Kinematics for Serial Manipulators, Importance of Singularities. Introduction to Dynamic Modelling: Forward and Inverse Dynamics- Equations of Motion using Euler-Lagrange formulation, Newton Euler Formulation.</p>	9
IV	<p>Introduction to Robot Control: Basics of Control: Open Loop- Closed Loop, Transfer Functions, Control Laws: P, PD, PID, Linear and Non-linear Controls; Control Hardware and Interfacing; Embedded Systems: Microcontroller Architecture and Integration with Sensors, Actuators, Components. Introduction to Robot Programming – Programming Methods, Robot Language Classification, Robot Language Structure, Elements and its Functions. Motion, End-Effector and Sensor Commands in VAL Programming Language. Simple Programs.</p>	9
V	<p>Recent Developments in Robotics. Mobile Robots: Mobile Robot Kinematics, Navigation. Humanoid Robotics: Biped Locomotion, Imitation Learning. Collaborative Robots: Collaborative Robot, Collaborative Operation, Applications. Artificial Intelligence in Robotics: Applications in Unmanned Systems, Defense, Medical, Industries, etc. Industrial Applications of Robots in Material Handling and Assembly. Robotics and Automation for Industry 4.0., Robot Safety. Social Robotics.</p>	9
Total hours		45

vi) ASSESSMENT PATTERN

Mark distribution

Total Marks	Continuous Internal Evaluation Marks	End Semester Evaluation Marks	End Semester Examination Duration
150	50	100	3 Hours



Continuous Internal Evaluation Pattern:

Attendance	10 Marks
Continuous Assessment Tests (2 numbers)	25 Marks
Assignment/Quiz/Course project	15 Marks

End Semester Examination Pattern:

There will be two parts; Part A and Part B. Part A contain 10 questions with 2 questions from each module, having 3 marks for each question. Students should answer all questions. Part B contains 2 questions from each module of which student should answer



PROGRAMME ELECTIVE-V

Course Code	Course Name	Category	L	T	P	Credit	Year of Introduction
EC1U44A	MECHATRONICS	PEC	3	0	0	3	2020

i) COURSE OVERVIEW

This course introduces students to the rapidly emerging, multi-disciplinary, and exciting field of Mechatronics

ii) COURSE OUTCOMES

After the completion of the course, the student will be able to:

Course Outcomes	Description	Level
CO 1	Understand the working principles of various sensors and actuators in Mechatronics systems and be able to choose the suitable one for the real world application	Understand
CO 2	Formulate and simulate models of mechatronics systems	Apply
CO 3	Explain the implementation of PLC in mechatronics applications	Understand
CO 4	Explain the standard fabrication techniques and principle of operation of MEMS devices	Understand
CO 5	Design and analyse the commonly encountered mechatronics systems for real time application	Analyze

iii) SYLLABUS

Introduction to Mechatronics: Structure of Mechatronics system. Comparison between traditional and mechatronics approach. Sensors - Characteristics -Temperature, flow, pressure sensors. Displacement, position and proximity sensing by magnetic, optical, ultrasonic, inductive, capacitive and eddy current methods. Encoders: incremental and absolute. Resolvers and synchros. Piezoelectric sensors. Acoustic Emission sensors. vibration sensors. Force and tactile sensors. Range finders: ultrasonic and light base range finders

Actuators: Hydraulic and Pneumatic actuators - Directional control valves, pressure control valves, process control valves. Rotary actuators. Development of simple hydraulic and pneumatic circuits using standard Symbols. Electrical drives: DC, AC, brushless, servo and stepper motors. Harmonic drive. Magnetostrictive actuators and piezoelectric actuators.



System modelling - Mathematical models and basic building blocks of general mechanical, electrical, fluid and thermal systems. Typical elements of open and closed loop control systems. Adaptive controllers for machine tools. Programmable Logic Controllers (PLC) –Basic structure, input/ output processing. Programming: Timers, Internal Relays, Counters and Shift registers. Development of simple ladder programs for specific purposes.

Micro Electro Mechanical Systems (MEMS): Fabrication: Deposition, Lithography, Micromachining methods for MEMS -Surface and Bulk, Deep Reactive Ion Etching (DRIE) and LIGA processes. Principle, fabrication and working of MEMS based pressure sensor, accelerometer and gyroscope.

Mechatronics in Robotics- choice of Sensors and Actuators. Robotic vision system – Image acquisition: Vidicon, charge coupled device (CCD) and charge injection device (CID) cameras. Image processing techniques: histogram processing: sliding, stretching, equalization and thresholding. Case studies of Mechatronics systems: Automatic camera, bar code reader, simple weighing machine, pick and place robot, automatic car park barrier system, automobile engine management system.

iv) (a) TEXT BOOKS

- 1) Bolton W., Mechatronics: Electronic Control Systems in Mechanical and Electrical Engineering, Person Education Limited, New Delhi, 2007
- 2) Ramachandran K. P., G. K. Vijayaraghavan, M. S. Balasundaram, Mechatronics: Integrated Mechanical Electronic Systems, Wiley India Pvt. Ltd., New Delhi, 2008.
- 3) Saeed B. Niku, Introduction to Robotics: Analysis, Systems, Applications, Person Education, Inc., New Delhi, 2006.
- 4) Devdas Shetty, Richard A. Kolk, “Mechatronics System Design”, Thomson Learning Publishing Company, Vikas publishing house, Second edition, 2001.

(b) REFERENCES

- 1) David G. Aldatore, Michael B. Histan, Introduction to Mechatronics and Measurement Systems, McGraw-Hill Inc., USA, 2003.
- 2) Gordon M. Mair, Industrial Robotics, Prentice Hall International, UK, 1998.
- 3) HMT, Mechatronics, Tata McGraw-Hill Publishing Company Ltd., New Delhi, 2004.
- 4) Vijay K. Varadan, K. J. Vinoy, S. Gopalakrishnan, Smart Material Systems and MEMS: Design and Development Methodologies, John Wiley & Sons Ltd., England, 2006.
- 5) Bishop, Robert H. The Mechatronics Handbook-2 Volume Set. CRC press, 2002.



v) COURSE PLAN

Module	Contents	No. of hours
I	Introduction to Mechatronics: Structure of Mechatronics system. Comparison between traditional and mechatronics approach. Sensors - Characteristics -Temperature, flow, pressure sensors. Displacement, position and proximity sensing by magnetic, optical, ultrasonic, inductive, capacitive and eddy current methods. Encoders: incremental and absolute. Resolvers and synchros. Piezoelectric sensors. Acoustic Emission sensors. vibration sensors. Force and tactile sensors. Range finders: ultrasonic and light base range finders	9
II	Actuators: Hydraulic and Pneumatic actuators - Directional control valves, pressure control valves, process control valves. Rotary actuators. Development of simple hydraulic and pneumatic circuits using standard Symbols. Electrical drives: DC, AC, brushless, servo and stepper motors. Harmonic drive. Magnetostrictive actuators and piezoelectric actuators.	9
III	System modelling - Mathematical models and basic building blocks of general mechanical, electrical, fluid and thermal systems. Typical elements of open and closed loop control systems. Adaptive controllers for machine tools. Programmable Logic Controllers (PLC) –Basic structure, input/ output processing. Programming: Timers, Internal Relays, Counters and Shift registers. Development of simple ladder programs for specific purposes.	9
IV	Micro Electro Mechanical Systems (MEMS): Fabrication: Deposition, Lithography, Micromachining methods for MEMS - Surface and Bulk, Deep Reactive Ion Etching (DRIE) and LIGA processes. Principle, fabrication and working of MEMS based pressure sensor, accelerometer and gyroscope.	9
V	Mechatronics in Robotics- choice of Sensors and Actuators. Robotic vision system – Image acquisition: Vidicon, charge coupled device (CCD) and charge injection device (CID) cameras. Image processing techniques: histogram processing: sliding, stretching, equalization and thresholding. Case studies of Mechatronics systems: Automatic camera, bar code reader, simple weighing machine, pick and place robot, automatic car park barrier system, automobile engine management system.	9
	Total hours	45

**vi) ASSESSMENT PATTERN****Mark distribution**

Total Marks	Continuous Internal Evaluation Marks	End Semester Evaluation Marks	End Semester Examination Duration
150	50	100	3 Hours

Continuous Internal Evaluation Pattern:

Attendance	10 Marks
Continuous Assessment Tests (2 numbers)	25 Marks
Assignment/Quiz/Course project	15 Marks

End Semester Examination Pattern:

There will be two parts; Part A and Part B. Part A contain 10 questions with 2 questions from each module, having 3 marks for each question. Students should answer all questions. Part B contains 2 questions from each module of which student should answer any one. Each question can have maximum 2 sub-divisions and carry 14 marks.



Course Code	Course Name	Category	L	T	P	Credit	Year of Introduction
EC1U44B	OPTIMIZATION TECHNIQUES	PEC	2	1	0	3	2020

i) COURSE OVERVIEW

This course aims to provide a broad picture of various applications of optimization methods used in engineering.

ii) COURSE OBJECTIVES

Learn the different optimization techniques and how to apply them for engineering problems.

iii) COURSE OUTCOMES

After the completion of the course, the student will be able to:

Course Outcomes	Description	Level
CO 1	Formulate and classify different optimisation problems.	Apply
CO 2	Apply classical and numerical methods solving linear and non-linear optimization problems.	Apply
CO 3	Apply modern methods of optimisation for solving optimisation problems.	Apply

iv) SYLLABUS

Introduction to classical method: Engineering applications of optimization, Formulation of design problems as mathematical programming problems. Classification of optimization problems/techniques. Classical optimization: unconstrained single and multivariable optimisation, Constrained optimization. Linear, Convex and non-convex optimization problems. KKT conditions.



Linear programming problems: Mathematical formulation of LP Problems, Solving using Simplex method and Graphical method.

Game Theory, Network path models: Game Theory: Introduction, 2- person zero – sum game -Saddle point; Mini-Max and Maxi- Min Theorems (statement only)- Graphical solution ($2 \times n$, $m \times 2$ game), dominance property. Introduction to network tree - Minimal Spanning Tree - Prim's Algorithm. Shortest path problems- solution methods – Dijkstra's Method.

Nonlinear unconstrained optimization: Single variable optimization methods- Fibonacci search method, Newton Raphson method Multi-variable methods- Hook-Jeeves pattern search method, Cauchy's (steepest descent) method.

Modern methods of optimization: Introduction to Genetic algorithm, Basic GA framework GA operators: Encoding, Crossover, Selection, Mutation. Introduction to Fuzzy logic. Fuzzy sets and membership functions. Operations on Fuzzy sets. Optimization of Fuzzy Systems.

v) a) TEXT BOOKS

1. S.S.Rao, Engineering Optimization.; Theory and Practice; Revised 4th Edition, New Age International Publishers, New Delhi, 2004
2. H.A. Taha, "Operations Research", 5/e, Macmillan Publishing Company, 1992.
3. Kanti Swarup, P.K.Gupta and Man Mohan, Operations Research, Sultan Chand and Sons, 2017

b) REFERENCES

1. Kalynamoy Deb. "Optimization for Engineering Design- Algorithms and Examples", Prentice-Hall of India Pvt. Ltd., New Delhi, 2012
2. A. Ravindran, D. T. Phillips, J. J. Solberg, Operations Research – Principles and Practice, John Wiley and Sons, 2007
3. Ashok D Belegundu, Tirupathi R Chandrupatla, "Optimization concepts and Application in Engineering", Pearson Education, 2011
4. Hadley, G. "Linear programming", Narosa Publishing House, New Delhi, 1972
5. J. S. Arora, Introduction to Optimum Design, McGraw-Hill Book Company, 2011



vi) COURSE PLAN

Module	Contents	No. of hours
I	Engineering applications of optimization, Formulation of design problems as mathematical programming problems, objective function, constraints, Classification of optimization problems/techniques. Linear, convex, and non-convex. Unconstrained optimization: Unconstrained one dimensional necessary and sufficient conditions for optimality Algorithms for one-dimensional unconstrained optimization problem –Fibonacci, golden section	9
II	Algorithms and Constrained Optimization Unconstrained multi-dimensional necessary and sufficient conditions for optimality, Algorithms for multi-dimensional unconstrained optimization problems –Steepest Descent, Newton’s methods. Constrained optimization: Lagrangian method - First order Necessary KKT Conditions, Second order sufficient conditions, Duality (Concept)	9
III	Linear programming problems Mathematical formulation of LP Problems Slack, surplus and artificial variables, Reduction of a LPP to the standard form, feasible solutions. Graphical solution method simplex algorithm and solution using tabular method, optimality conditions and degeneracy Duality in linear programming	9
IV	Nonlinear unconstrained optimization Single variable optimization methods- Fibonacci search method, Newton Raphson method, Multi-variable methods- Hook-Jeeves pattern search method	9
V	Modern methods of optimization Introduction to Genetic algorithm, Basic GA framework GA operators: Encoding, Crossover, Selection, Mutation, Introduction to Fuzzy logic. Fuzzy sets and membership functions. Operations on Fuzzy sets. Optimization of Fuzzy Systems	9
	Total hours	45

**vi) ASSESSMENT PATTERN****Mark distribution**

Total Marks	Continuous Internal Evaluation Marks	End Semester Evaluation Marks	End Semester Examination Duration
150	50	100	3 Hours

Continuous Internal Evaluation Pattern:

Attendance	10 Marks
Continuous Assessment Tests (2 numbers)	25 Marks
Assignment/Quiz/Course project	15 Marks

End Semester Examination Pattern:

There will be two parts; Part A and Part B. Part A contain 10 questions with 2 questions from each module, having 3 marks for each question. Students should answer all questions. Part B contains 2 questions from each module of which student should answer any one. Each question can have maximum 2 sub-divisions and carry 14 marks.



Course Code	Course Name	Category	L	T	P	Credit	Year of Introduction
EC1U44C	COMPUTER VISION	PEC	2	1	0	3	2020

i) PREREQUISITE: Nil

ii) COURSE OVERVIEW:

This course aims to develop the knowledge of various methods, algorithms and applications of Computer Vision.

iii) COURSE OUTCOMES

After the completion of the course, the student will be able to:

Course Outcomes	Description	Level
CO 1	Explain digital filtering operations for CV applications.	Understand
CO 2	Apply basic morphological and boundary operators for Computer vision applications.	Apply
CO 3	Apply edge, corner detection algorithms to locate objects in an image.	Apply
CO 4	Apply optical flow algorithms to detect moving objects in a video.	Apply
CO 5	Analyse a given scene using appropriate computer vision algorithms to detect/recognize objects and to implement it in real time practical applications.	Apply

iv) SYLLABUS

Review of image processing techniques - Digital filters, Mathematical morphology, connectedness, object labelling and counting, Boundary descriptors – Chain codes. Properties of Binary Regions, Feature Detection and Image Synthesis, Edge detection, Normalized cuts, Graph cuts, energy-based methods, Hough transform-Line and curve detection, Shape from X, Photometric stereo, Texture Occluding contour detection. Motion Analysis, Optical Flow, Structure from motion, Object recognition, Bayes rule and ML methods. Eigen faces, Face detection, Face recognition, Application, Examples of real time applications: In-vehicle vision system.

v) a) TEXT BOOKS

- 1) E. R .Davies, Computer and Machine Vision -Theory Algorithm and Practicalities, Academic Press, 2012
- 2) Richard Szeliski, Computer Vision: Algorithms and Applications, ISBN 978-1-84882-935-0, Springer 2011.



- 3) David Forsyth and Jean Ponce, Computer Vision: A Modern Approach, Pearson India, 2002.

b) REFERENCES

- 1) Simon Goodfellow, Bengio, and Courville, Deep Learning, MIT Press, 2006.
- 2) Daniel Lelis Baggio, Khvedchenia Ievgen, Shervin Emam, David Millan Escriva, Naureen Mahmoo, Jason Saragi, Roy Shilkrot, Mastering OpenCV with Practical Computer Vision Projects, Packt Publishing Limited, 2012
- 3) Simon J D Prince, Computer Vision: Models, Learning, and Inference, Cambridge University Press, 2012.
- 4) R. J. Schalkoff, Digital Image Processing and Computer Vision, John Wiley, 2004.
- 5) D. L. Baggio et al., —Mastering OpenCV with Practical Computer Vision Projects, Packt Publishing, 2012.
- 6) Jan Erik Solem, —Programming Computer Vision with Python: Tools and algorithms for analyzing images, O'Reilly Media, 2012.

vi) COURSE PLAN

Module	Contents	No. of hours
I	Review of image processing techniques: Digital filters, linear filters- Homomorphic filtering, Point operators- Histogram, neighbourhood operators, thresholding	10
II	Mathematical morphology, Binary shape analysis, Binary shape analysis, Erosion, Dilation, Opening and Closing, Hit-or-Miss Transform, connectedness, object labelling and counting, Boundary descriptors – Chain codes. Properties of Binary Regions, Geometric Features, Statistical Shape Properties.	9
III	Feature Detection and Image Synthesis, Edge detection – edges, lines, active contours, Split and merge, Mean shift and mode finding, Normalized cuts, Graph cuts, energy-based methods- Cranny’s Algorithm, Corner detection, Harris corner detection algorithm. Hough transform-Line and curve detection.	9
IV	Shape from X - Shape from shading, Photometric stereo, Texture Occluding contour detection. Motion Analysis- Regularization theory, Optical Flow: brightness constancy equation, aperture problem, Horn-Shunck method, Lucas-Kanade method. Structure from motion	9
V	Object recognition-Shape correspondence and shape matching PCA, SVM, LDA, Bayes rule and ML methods. Eigen faces, Face detection, Face recognition, Application: Scene analysis. Examples of real time applications: In-vehicle vision system.	8
	Total hours	45

**vii) ASSESSMENT PATTERN****Mark distribution**

Total Marks	Continuous Internal Evaluation Marks	End Semester Evaluation Marks	End Semester Examination Duration
150	50	100	3 Hours

Continuous Internal Evaluation Pattern:

Attendance	10 Marks
Continuous Assessment Tests (2 numbers)	25 Marks
Assignment/Quiz/Course project	15 Marks

End Semester Examination Pattern:

There will be two parts; Part A and Part B. Part A contain 10 questions with 2 questions from each module, having 3 marks for each question. Students should answer all questions. Part B contains 2 questions from each module of which student should answer any one. Each question can have maximum 2 sub-divisions and carry 14 marks.



Course Code	Course Name	Category	L	T	P	Credit	Year of Introduction
EC1U44D	LOW POWER VLSI	PEC	2	1	0	3	2020

i) **PREREQUISITE:** EC1U20A- Solid State Devices, EC1U30F- VLSI Design

ii) **COURSE OVERVIEW**

This course aims to impart the basic knowledge in designing of Low power VLSI Circuits.

iii) **COURSE OUTCOMES**

After the completion of the course, the student will be able to

Course Outcomes	Description	Level
CO 1	Identify various short channel effects and various sources of power dissipation in MOSFET.	Understand
CO 2	Apply various power reduction techniques to circuits.	Apply
CO 3	Apply various clocked and non-clocked design styles for logic implementation.	Apply
CO 4	Apply Adiabatic and reversible logic for circuit implementation.	Apply

iv) **SYLLABUS**

Physics of Power dissipation in MOSFET devices- MIS Structure, Short channel effects- Deep submicron transistor design issues.

Sources of power dissipation in CMOS- Dynamic Power Dissipation- Short Circuit Power- Glitching Power, Static Power Dissipation, Leakage Power Dissipation, Gate level power analysis.

Power Reduction Techniques- Supply voltage Scaling Approaches- leakage power reduction Techniques –Transistor and Gate Sizing for Dynamic and Leakage Power Reduction.

Circuit design style - Clocked design style- Non clocked circuit design style.

Adiabatic switching – Adiabatic charging, adiabatic amplification, One stage and two stage adiabatic buffer, Adiabatic logic gates, pulsed power supplies, Reversible logic basic concepts.

v) a) **TEXT BOOKS**

- 1) Gray Yeap, Practical low power digital VLSI design, Springer, 1998
- 2) Kaushik Roy, Sharat C Prasad, Low power CMOS VLSI circuit design, Wiley India, 2009

b) **REFERENCES**

- 1) Abdellatif Bellaouar, Mohamed I Elmasry, Low power digital VLSI design, Kluwer Academic, 1995
- 2) Anatha P Chandrakasan, Robert W Brodersen, Low power digital CMOS Design, Kluwer Academic, 1995
- 3) Christian Piguet, Low power CMOS circuits, Taylor & Francis, 2006.



- 4) Kiat Seng Yeo, Kaushik Roy, Low voltage, low power VLSI sub systems, Tata McGraw Hill, 2004

vi) COURSE PLAN

Module	Contents	No. of hours
I	Physics of Power dissipation in MOSFET devices: Need for low power circuit design, MIS Structure, Short channel effects-surface scattering, punch through, velocity saturation, impact ionization Hot electron effects, Drain Induced Barrier Lowering, Deep submicron transistor design issues.	7
II	Sources of power dissipation in CMOS: Dynamic Power Dissipation: Charging and Discharging capacitance power dissipation, Short Circuit Power: Short Circuit Current of Inverter, Short circuit current dependency with input and output load, Glitching Power, Static Power Dissipation, Leakage Power Dissipation, Gate level power analysis: Capacitive, internal and Static power dissipation of gate level circuit.	9
III	Power Reduction Techniques: Supply voltage Scaling Approaches: Multi VDD and Dynamic VDD, leakage power reduction Techniques – Transistor stacking, VTCMOS, MTCMOS, DTCMOS, Power gating, Clock gating for Dynamic power dissipation, Transistor and Gate Sizing for Dynamic and Leakage Power Reduction.	10
IV	Circuit design style: Clocked design style- Basic concept, Domino logic (domino NAND gate), Differential Current Switch Logic. Non clocked circuit design style-fully complementary logic. NMOS and pseudo –NMOS logic, differential cascade voltage switch logic(DCVS)	10
V	Adiabatic switching – Adiabatic charging, adiabatic amplification, One stage and two stage adiabatic buffer, Adiabatic logic gates, pulsed power supplies, Reversible logic basic concepts.	9
	Total hours	45

Simulation Assignments

At least one assignment should be simulation based using any simulation software. It can be the design of a circuit in any one of the clocked or non-clocked style and perform power analysis. Samples of simulation assignments are given below.

1. Implement NAND gate in conventional CMOS and domino logic and perform power analysis in each case.
2. Implement any sample logic function in DCVS.



3. Apply threshold voltage scaling method to a logic function implemented in conventional style and perform power analysis

vii) ASSESSMENT PATTERN**viii) Mark distribution**

Total Marks	Continuous Internal Evaluation Marks	End Semester Evaluation Marks	End Semester Examination Duration
150	50	100	3 Hours

Continuous Internal Evaluation Pattern:

Attendance	10 Marks
Continuous Assessment Tests (2 numbers)	25 Marks
Assignment/Quiz/Course project	15 Marks

End Semester Examination Pattern:

There will be two parts; Part A and Part B. Part A contain 10 questions with 2 questions from each module, having 3 marks for each question. Students should answer all questions. Part B contains 2 questions from each module of which student should answer any one. Each question can have maximum 2 sub-divisions and carry 14 marks.



Course Code	Course Name	Category	L	T	P	Credit	Year of Introduction
EC1U44E	INTERNET OF THINGS	PEC	2	1	0	3	2020

i) **PREREQUISITE:** Students should have a basic knowledge in Embedded systems.

ii) **COURSE OVERVIEW**

This course aims to develop skills in IoT system development and to apply the same in real life applications.

iii) **COURSE OUTCOMES**

After the completion of the course the student will be able to:

Course Outcomes	Description	Level
CO 1	Understand the IoT fundamentals and architecture modelling	Understand
CO 2	Understand the smart things in IoT and functional blocks	Understand
CO 3	To understand the communication networks and protocols used in IoT.	Understand
CO 4	To understand the cloud resources, data analysis and applications.	Understand
CO 5	To apply the IoT processes in embedded applications.	Apply

iv) **SYLLABUS**

Introduction to IoT- Definitions and Characteristics, Architectural View, Logical Design of IoT-Functional blocks, Communication models, IoT Levels & Deployment Templates.

IoT and M2M- M2M, Difference between IoT and M2M, SDN and NFV for IoT, Smart Objects: Sensors, Actuators, and Smart Objects, Wireless Sensor Networks, Communication Protocols for Wireless Sensor Networks- Connecting Smart Objects

Unified Data Standards –Protocols –IEEE 802.15.4 -The Physical Layer, The Media-Access Control Layer, Uses of 802.15.4, Modbus, ZigBee-Zigbee Architecture- LoRaWAN - Standardization and Alliances, Physical Layer, MAC Layer, Topology, LTE-M, NB-IoT- Network layer. IP-based protocols -6LoWPAN and RPL

Data Collection, storage and computing Using a Cloud Platform-Introduction, Cloud Computing Paradigm for Data Collection, Storage and Computing, Cloud Deployment Models, Cloud based platforms. IoT Physical Devices & Endpoints-IoT Device –Raspberry-Pi -Board-Linux on Raspberry-Pi-Raspberry-Pi Interfaces. Raspberry Pi interfacing and Programming.

IoT privacy, security and vulnerabilities solutions, vulnerabilities, security requirements, threat



analysis, security tomography, layered attacker model, Identity management. Smart and Connected Cities-An IoT Strategy for Smarter Cities, Smart City Security Architecture - Smart City Use-Case Examples

v) (a) TEXT BOOKS

1. Vijay Madiseti and ArshdeepBahga, “Internet of Things (A Hands-on- Approach)”, 1st Edition, VPT, 2014 (Module1,2,4)
2. David Hanes, Gonzalo Salgueiro, Patrick Grossetete, Rob Barton and Jerome Henry, IoT Fundamentals: Networking Technologies, Protocols and Use Cases for Internet of Things, Cisco Press, 2017. (Module2,3,5)
3. Rajkamal, “Internet of Things: Architecture and Design Principles”, McGraw Hill (India) Private Limited.
4. Raspberry Pi Cookbook, Software and Hardware Problems and solutions, Simon Monk, O'Reilly (SPD), 2016, ISBN.

(b) REFERENCES

1. Olivier Hersent, David Boswarthick, Omar Elloumi, “The Internet of Things –Key applications and Protocols”, Wiley, 2012 (Module 3)
2. Al-Fuqaha et al. Internet of things: A survey on enabling technologies, protocols, and applications. IEEE Communications Surveys & Tutorials (2015), pp. 2347- 2376.
3. The Internet of Things (The MIT Press Essential Knowledge series) Paperback – March 20, 2015 by Samuel Greengard
4. The Internet of Things: Converging Technologies for Smart Environments and Integrated Ecosystems, Ovidu Vermesan and Peter Friess, River Publishers.
5. Internet of Things - From Research and Innovation to Market Deployment-RIVER PUBLISHERS, PETER FRIESS, OVIDIU VERMESAN (Editors)
6. Internet of Things Security and Data Protection, Sébastien Ziegler, Springer International Publishing 2019.

vi) COURSE PLAN

Module	Contents	No. of hours
I	Introduction to IoT technology: Definitions and Characteristics of IoT, IoT Architectural View, Physical Design of IOT, Logical Design of IoT- IoT Functional blocks, IoT communication models, IoT Enabling Technologies, IoT Levels & Deployment Templates.	9
II	IoT and M2M- M2M, Difference between IoT and M2M, SDN and NFV for IoT, Smart Objects: The “Things” in IoT: Sensors, Actuators, and Smart Objects, Sensor Networks- Wireless Sensor Networks (WSNs), Communication Protocols for Wireless Sensor Networks-Connecting Smart Objects- Communication Criteria.	9
III	Unified Data Standards –Protocols –IEEE 802.15.4 -The Physical Layer, The Media-Access Control Layer, Uses of 802.15.4 ,The Future of 802.15.4: 802.15.4e and 802.15.4g–Modbus– ZigBee-Zigbee Architecture- LoRaWAN -Standardization and Alliances, Physical Layer, MAC Layer, Topology, LTE-M, NB-IoT-Network	9



	layer –The next generation: IP-based protocols - 6LoWPAN and RPL, Overview of the 6LoWPAN Adaptation Layer.	
IV	Data Collection, storage and computing Using a Cloud Platform-Introduction, Cloud Computing Paradigm for Data Collection, Storage and Computing-Cloud Computing Paradigm, Cloud Deployment Models-Everything as a Service and Cloud Service Models-SaaS, PaaS, IaaS, DaaS. Cloud based platforms-XIVELY, NIMBITS. IoT Physical Devices & Endpoints-IoT Device-Building blocks – Raspberry-Pi -Board-Linux on Raspberry-Pi-Raspberry-Pi Interfaces (serial, SPI, I2C). Raspberry Pi interfacing and programming examples using python (LED, switch, sensor, serial, SPI, I2C devices). Controlling GPIO outputs and displaying sensor readings using web interface/cloud. (Python programming is required only for assignments and projects and not for examinations. Other end nodes and platforms can also be used).	9
V	IoT privacy, security and vulnerabilities solutions, vulnerabilities, security requirements, threat analysis, security tomography, layered attacker model, Identity management, access control, secure message communication. Smart and Connected Cities-An IoT Strategy for Smarter Cities-Vertical IoT Needs for Smarter Cities, Global vs. Siloed Strategies-Smart City IoT Architecture-Street Layer, City Layer, Data Center Layer, Services Layer- Smart City Security Architecture. Smart City Use-Case Examples – Street lighting, smart parking, smart traffic and air pollution monitoring	9
	Total hours	45

vii) ASSESSMENT PATTERN

Mark distribution

Total Marks	Continuous Internal Evaluation Marks	End Semester Evaluation Marks	End Semester Examination Duration
150	50	100	3 Hours

Continuous Internal Evaluation Pattern:

Attendance	10 Marks
Continuous Assessment Tests (2 numbers)	25 Marks
Assignment/Quiz/Course project	15 Marks

End Semester Examination Pattern:

There will be two parts; Part A and Part B. Part A contain 10 questions with 2 questions from each module, having 3 marks for each question. Students should answer all questions. Part B contains 2 questions from each module of which student should answer any one. Each question can have maximum 2 sub-divisions and carry 14 marks.



Course Code	Course Name	Category	L	T	P	Credit	Year of Introduction
EC1U44F	RENEWABLE ENRGY SYSTEM	PEC	3	0	0	3	2020

i) **PREREQUISITE:** NIL

ii) **COURSE OVERVIEW**

This course helps the students to understand environmental issues with conventional fuels, the new methodologies/technologies for the effective utilization of renewable energy sources. They will be conversant with the characteristics of solar PV and wind power sources. Also, they will have an in-depth understanding of electronic conversion systems application to renewable energy generation systems and the synchronization with smart grid systems. The courses equip the students to pursue further specialized areas of study such as renewable energy and green consumer electronics, industrial control systems and smart grid, and renewable energy system which are essentially based on this course.

iii) **COURSE OUTCOMES**

After the completion of the course, the student will be able to

Course Outcomes	Description	Level
CO 1	Understand the need, importance and scope of various Non-Conventional sources of energy	Understand
CO 2	Outline the concepts and technologies related to renewable energy systems using wind and Solar-PV	Understand
CO 3	Understand the integration of smart grid with renewable energy systems	Understand
CO 4	Explain the concept of distribution management system	Understand
CO 5	Describe the fundamentals of Smart metering	Understand

iv) **SYLLABUS**

Introduction to Renewable Energy (RE) Sources: World energy scenario, Over view of conventional energy sources, Renewable energy in India, An overview of types of renewable energy systems, Solar Energy: Introduction to photovoltaic (PV) systems, Grid interfacing-with isolation, without isolation, Maximum power point tracking Methods (MPPT), Wind Energy: Sources and potentials, Evaluation of Wind Intensity, Topography, General Classification of Wind Turbines, Electronic conversion systems application to renewable energy generation systems: Basic schemes and functional advantages, Issues in integration of converter based sources; Network voltage management; Introduction to grid connectivity of RE systems, smart grid and emerging technologies, Supervisory control and data acquisition (SCADA).



v) a) TEXT BOOKS

- 1) Nayak J. K. and Sukhatme S. P. (2006), Solar Energy: Principles of Thermal Collection and Storage, Tata McGraw Hill.
- 2) Muhammad H. R. (2004); Power Electronics: Circuits, Devices and Applications, Pearson Prentice Hall.
- 3) Nick Jenkins, JanakaEkanayake, [et al.] Smart Grid Technology and Applications, Wiley India Ltd.
- 4) Ali Keyhani, Design of Smart Power Grid Renewable Energy Systems, Wiley-IEEE Press 2016.

b) REFERENCES

- 1) Non-Conventional Energy Sources /G.D. Rai
- 2) Renewable Energy Technologies /Ramesh & Kumar /Narosa
- 3) Integration of alternative sources of energy /Felix A. Farret, M. Godoy simoes
- 4) Wind power plants and projects developments, Joshua Earnest and T Wizelius, PHI, New Delhi, 2011.
- 5) Handbook of renewable energy technology, World Scientific, Singapore, 2011.
- 6) Garg H. P. and Prakash S. (2000); Solar Energy: Fundamental and Application, Tata McGraw Hill
- 7) Goswami D. Y. (2015); Principles of Solar Engineering, Taylor and Francis
- 8) Gellings C. W. (2009); The Smart Grid: Enabling Energy Efficiency and Demand Response, First Edition, CRC Press
- 9) Teodorescu R. Liserre M. Rodriguez P. (2011); Grid Converters for Photovoltaic and Wind Power Systems, First Edition, Wiley-IEEE Press
- 10) Ali Keyhani, Muhammad Marwali, Smart Power Grids 2011, Springer-Verlag Berlin Heidelberg 2012.

vi) COURSE PLAN

Module	Contents	No. of hours
I	Introduction to Renewable Energy (RE)Sources: World energy scenario, Over view of conventional energy sources, their limitation, need of renewable energy, potential & development of renewable energy sources, Renewable energy in India, An overview of types of renewable energy systems - Wind power, Hydropower (micro and mini), Solar energy, Biomass, Bio-fuel, Geothermal Heat energy, Pros and cons; Applications.	9
II	Solar Energy: Introduction to photovoltaic (PV) systems - Principle of PV conversion; Commercial solar cell, Thin film PV device fabrication - LPCVD, APCVD, PECVD; Tandem Solar cell fabrication; Solar power extraction using PV-Cells, I-V Characteristics, PV-Inverters without D.C. to D.C. converters, stand alone and grid collected PV systems, Grid	10



	interfacing-with isolation, without isolation, Maximum power point trackingMethods(MPPT), PV-Inverters with D.C. to D.C. converters-on low frequency side and high frequency side with isolation, without isolation.	
III	Wind Energy: Sources and potentials, Evaluation of Wind Intensity, Topography, General Classification of Wind Turbines-Rotor Turbines, Multiple-Blade Turbines, Drag Turbines, Lifting Turbines, System Toroidal Rotor Amplifier Platform (TARP)–Wind amplified rotor platform (WARP), Generators and speed control used in wind power energy: Fixed speed with capacitor bank, Rotor resistance control, SCIG and DFIG, Synchronous Generatorexternal magnetized, Synchronous Generator-permanent magnets	8
IV	Electronic conversion systems application to renewable energy generation systems: Basic schemes and functional advantages, Power control and management systems for grid integration, island detection systems, synchronizing with the grid; Issues in integration of converter-based sources; Network voltage management; Power quality management and Frequency management; Influence of PV/WECS on system transient response	8
V	Introduction to grid connectivity of RE systems, smart grid and emerging technologies, operating principles and models of smart grid components, key technologies for generation, networks, loads and their control capabilities; Evolution of electricity metering, key components of smart metering, overview of the hardware used for smart meters, smart metering protocols. Structure and main components of a distribution management system, Supervisory control and data acquisition (SCADA), distribution system modelling, new trends for smart grids, topology analysis, power flow analysis.	10
	Total hours	45

**vii) ASSESSMENT PATTERN****Mark distribution**

Total Marks	Continuous Internal Evaluation Marks	End Semester Evaluation Marks	End Semester Examination Duration
150	50	100	3 Hours

Continuous Internal Evaluation Pattern:

Attendance	10 Marks
Continuous Assessment Tests (2 numbers)	25 Marks
Assignment/Quiz/Course project	15 Marks

End Semester Examination Pattern:

There will be two parts; Part A and Part B. Part A contain 10 questions with 2 questions from each module, having 3 marks for each question. Students should answer all questions. Part B contains 2 questions from each module of which student should answer any one. Each question can have maximum 2 sub-divisions and carry 14 marks.



Course Code	Course Name	Category	L	T	P	Credit	Year of Introduction
EC1U44G	ORGANIC ELECTRONICS	PEC	3	0	0	3	2020

i) **PREREQUISITE:** PH0U10A -Engineering Physics, EC1U20A -Solid State Devices

ii) **COURSE OVERVIEW:** The goal of the course is to provide an insight into the theory behind organic electronics. It will give students the awareness of the largest alternative form of energy and how organic / polymer solar cells, photovoltaic cells and organic LEDs work.

iii) COURSE OUTCOMES

After the completion of the course the student will be able to:

Course Outcomes	Description	Level
CO 1	Describe the principle of charge transport in organic semiconductors.	Understand
CO 2	Explain the structure and working of multilayer OLEDs, OFETs and OPVs	Understand
CO 3	Distinguish the action of different layers used in organic devices with reference to the materials used.	Understand
CO 4	Explain different techniques employed in making organic electronic devices like OLEDs, OPVs and OFETs	Understand

iv) SYLLABUS

Conducting Polymers - conduction mechanism, Pi and Sigma electron band theory, Polymers fundamentals, Physics of organic semiconductors

Organic Electronic Devices - Basic device architecture inorganic devices, Multilayer architecture, Fabrication and characterization.

Organic Solar Cells - Plastic solar cells, Basic principles, Charge transport and exciton formation-effects, Processing of organic solar cells.

Organic Electronics-Materials Essential characteristics of electrode materials for organic electronic devices, Effect of ITO oxidative properties on efficiency and shelf life of organic electronic devices, Buffer organic layer protection to the active layer.

Techniques in Device making - Techniques in Organic electronic Device materials, Vapor deposition.

**v) a) TEXT BOOKS**

1. Bernier. Advanced synthetic metals, Elsevier (1999).
2. R.Farchioni(Editor)G.Grosso(Editor) Organic Electronic Materials. Conjugated polymers and low molecular weight organic solids, Springer series in materials science (2007).
3. Gregory Crawford. Flexible flat panel display, Wiley series in display technology(2005).
4. Klauk Hagen(ED), Wiley VCH. Organic electronics (2006).

b) REFERENCES

1. Gil. Semiconductors and Organic Materials for Opto electronic Application. Elsevier (1997).
2. Nalwa. Supra molecular photosensitive and electro–active materials Elsevier(2001).
3. Eguer. Thin film materials for large area electronics. Elsevier(1999).

vi) COURSE PLAN

Module	Contents	No. of hours
I	Conducting polymer, Organic semiconductor, conduction mechanism, Pi and Sigma electron band theory. Polymers fundamentals-conducting polymers. Organic semiconductors, charge transport in conjugated polymers. Conduction mechanism in doped polymeric semiconductors. Physics of organic semiconductors (Luminescence, injection and transports properties), Methods of developing organic semiconductors.	9
II	Basic device architecture in organic devices. Historical review. Organic light emitting diodes(OLED) and Polymer light emitting diodes (PLED). Multilayer architecture. Single layer architecture. Bulk hetero-junctions. Operating characteristics and electrical characterization. Flexible electronics : new display media. Flexible displays device architecture. Fabrication and characterization. Organic transistors. FETs: Principle and device architecture.	9
III	Plastic solar cells. Basic principles. Multilayer and heterojunction structures, cell architecture. Charge transport and exciton formation–effects of exciton diffusion, dissociation and luminescence. Photogeneration process in organic heterojunction photovoltaic cells. Processing of organic solar cells. Dye Sensitization– dye sensitized solar cell.	9



IV	Essential characteristics of electrode materials for organic electronic devices – work function. Conductivity and transparency factors. Indium Tin Oxide (ITO) as anode material. Effect of ITO oxidative properties on efficiency and shelf life of organic electronic devices, novel inorganic anode materials and their limitations. Buffer organic layer protection to the active layer. Doping the device and annealing the device for increased efficiency and shelf life– architecture.	9
V	Techniques in Organic electronic Device materials. Thin film coating techniques for device fabrication. Spin coating, dip coating, doctor blading screen printing, inkjet printing, vapor deposition. R.F and microwave plasma assisted film coating.	9
	Total hours	45

vii) ASSESSMENT PATTERN

Mark distribution

Total Marks	Continuous Internal Evaluation Marks	End Semester Evaluation Marks	End Semester Examination Duration
150	50	100	3 Hours

Continuous Internal Evaluation Pattern:

Attendance	10 Marks
Continuous Assessment Tests (2 numbers)	25 Marks
Assignment/Quiz/Course project	15 Marks

End Semester Examination Pattern:

There will be two parts; Part A and Part B. Part A contain 10 questions with 2 questions from each module, having 3 marks for each question. Students should answer all questions. Part B contains 2 questions from each module of which student should answer only one. Each question can have maximum 2 sub-divisions and carry 14 marks.



Course Code	Course Name	Category	L	T	P	Credit	Year of Introduction
EC1U40C	COMPREHENSIVE VIVA VOCE	PCC	1	0	0	1	2020

i) COURSE OVERVIEW

The objective of this Course viva is to ensure the basic knowledge of each student in the most fundamental core courses in the curriculum. The viva voce shall be conducted based on the core subjects studied from third to eighth semester. This course helps the learner to become competent in placement tests and other competitive examinations.

ii) GUIDELINES

- 1) The course should be mapped with a faculty and classes shall be arranged for practicing questions based on the core courses listed in the curriculum.
- 2) The viva voce will be conducted by the same three-member committee assigned for final project phase II evaluation. It comprises of Project coordinator, expert from Industry/research Institute and a senior faculty from a sister department.
- 3) The pass minimum for this course is 25.
- 4) The mark will be treated as internal and should be uploaded along with internal marks of other courses.
- 5) Comprehensive Viva should be conducted along with final project evaluation by the three-member committee.

iii) MARK DISTRIBUTION

Total marks: 50, only CIE, minimum required to pass: 25 Marks



Course Code	Course Name	Category	L	T	P	Credit	Year of Introduction
EC1U49C	PROJECT PHASE II	PWS	0	0	12	4	2020

i) **PREAMBLE:** The course 'Project Work' is mainly intended to evoke the innovation and invention skills in a student. The course will provide an opportunity to synthesize and apply the knowledge and analytical skills learned, to be developed as a prototype or simulation. The project extends to 2 semesters and will be evaluated in the 7th and 8th semester separately, based on the achieved objectives. One third of the project credits shall be completed in 7th semester and two third in 8th semester. It is recommended that the projects may be finalized in the thrust areas of the respective engineering stream or as interdisciplinary projects. Importance should be given to address societal problems and developing indigenous technologies

ii) **COURSE OVERVIEW:**

The aim of this course is to apply engineering knowledge in solving practical problems, to foster innovation in design of products, processes or systems, and to develop creative thinking in finding viable solutions to engineering problems.

iii) **COURSE OUTCOMES**

After the completion of the course, the student will be able to:

Course Outcomes	Description	Level
CO 1	Model and solve real world problems by applying knowledge across domains (Cognitive knowledge level: Apply).	Apply
CO 2	Develop products, processes or technologies for sustainable and socially relevant applications (Cognitive knowledge level: Apply).	Apply
CO 3	Function effectively as an individual and as a leader in diverse teams and to comprehend and execute designated tasks (Cognitive knowledge level: Apply).	Apply
CO 4	Plan and execute tasks utilizing available resources within timelines, following ethical and professional norms (Cognitive knowledge level: Apply).	Apply
CO 5	Identify technology/research gaps and propose innovative/creative solutions (Cognitive knowledge level: Analyze).	Analyse
CO 6	Organize and communicate technical and scientific findings effectively in written and oral forms (Cognitive knowledge level: Apply).	Apply



iv) TARGETS:

- In depth study of the topic assigned in the light of the report prepared under Phase - I;
- Review and finalization of the approach to the problem relating to the assigned topic.
- Preparing a detailed action plan for conducting the investigation, including teamwork.
- Detailed Analysis/ Modeling / Simulation/ Design/ Problem Solving/Experiment as needed.
- Final development of product/ process, testing, results, conclusions and future directions.
- Preparing a paper for Conference Presentation/ Publication in Journals, if possible.
- Presenting projects in Project Expos conducted by the University at the cluster level and/ or state level as well as others conducted in India and abroad.
- Filing Intellectual Property Rights (IPR) if applicable.
- Preparing a report in the standard format for being evaluated by the Department Assessment Board.
- Final project presentation and viva voce by the assessment board including the external expert.

v) EVALUATION GUIDELINES & RUBRICS

Total: 150 marks (Minimum required to pass: 75 marks).

- Project progress evaluation by guide: 30 Marks.
- Two interim evaluations by the Evaluation Committee: 50 Marks (25 marks for each evaluation).
- Final evaluation by the Final Evaluation committee: 40 Marks
- Quality of the report evaluated by the evaluation committee: 30 Marks

(The evaluation committee comprises HoD or a senior faculty member, Project coordinator and project supervisor. The final evaluation committee comprises of Project coordinator, expert from Industry/research/academic Institute and a senior faculty from a sister department).



MINORS



Course Code	Course Name	Category	L	T	P	Credit	Year of Introduction
ECOM 49B	MINI PROJECT	VAC	0	1	6	4	2020

i) COURSE OVERVIEW

The course aims

To estimate the ability of the students in transforming the theoretical knowledge studied in to a working model of an electronic system

For enabling the students to gain experience in organisation and implementation of small projects.

Design and development of Small electronic project based on hardware or a combination of hardware and software for electronics systems.

ii) COURSE OUTCOMES

After the completion of the course, the student will be able to:

Course Outcomes	Description	Level
CO 1	Practice acquired knowledge within the selected area of technology for project development.	Apply
CO 2	Identify, discuss and justify the technical aspects and design aspects of the project with a systematic approach.	Apply
CO 3	Reproduce, improve and refine technical aspects for engineering projects.	Apply
CO 4	Work as a team in development of technical projects.	Apply
CO 5	Communicate and report effectively project related activities and findings.	Apply

iii) COURSE PLAN

In this course, each group consisting of three/four members is expected to design and develop a moderately complex electronic system with practical applications, this should be a working model. The basic concept of product design may be taken into consideration.

Students should identify a topic of interest in consultation with Faculty/Advisor. Review the literature and gather information pertaining to the chosen topic. State the objectives and develop a methodology to achieve the objectives. Carryout the design/fabrication or develop codes/programs to achieve the objectives. Demonstrate the novelty of the project



through the results and outputs. The progress of the mini project is evaluated based on a minimum of two reviews.

The review committee may be constituted by the Head of the Department. A project report is required at the end of the semester. The product has to be demonstrated for its full design specifications. Innovative design concepts, reliability considerations, aesthetics/ergonomic aspects taken care of in the project shall be given due weight.

vi) ASSESSMENT PATTERN

Mark distribution

Total Marks	Continuous Internal Evaluation Marks	End Semester Evaluation Marks	End Semester Examination Duration
150	75	75	1 Hours

Evaluation

The internal evaluation will be made based on the product, the report and a viva- voce examination, conducted by a 3-member committee appointed by Head of the Department comprising HoD or a senior faculty member, Academic coordinator for that program, project guide/coordinator.

The Committee will be evaluating the level of completion and demonstration of functionality/specifications, presentation, oral examination, work knowledge and involvement.

Split-up of CIE

Component	Marks
Attendance	10
Marks awarded based on guide's evaluation	15
Project Report	10
Evaluation by Committee	40

Split-up of ESE

Component	Marks
Level of completion	10
Demonstration of functionality	25
Project Report	10
Viva-voce	20
Presentation	10



HONOURS



Course Code	Course Name	Category	L	T	P	Credit	Year of Introduction
EC1H49A	MINI PROJECT	VAC	0	1	6	4	2020

i) COURSE OVERVIEW

The course aims

To estimate the ability of the students in transforming the theoretical knowledge studied in to a working model of an electronic system

For enabling the students to gain experience in organisation and implementation of small projects.

Design and development of Small electronic project based on hardware or a combination of hardware and software for electronics systems.

ii) COURSE OUTCOMES

After the completion of the course, the student will be able to:

Course Outcomes	Description	Level
CO 1	Practice acquired knowledge within the selected area of technology for project development.	Apply
CO 2	Identify, discuss and justify the technical aspects and design aspects of the project with a systematic approach.	Apply
CO 3	Reproduce, improve and refine technical aspects for engineering projects.	Apply
CO 4	Work as a team in development of technical projects.	Apply
CO 5	Communicate and report effectively project related activities and findings.	Apply

iii) COURSE PLAN

In this course, each group consisting of three/four members is expected to design and develop a moderately complex electronic system with practical applications, this should be a working model. The basic concept of product design may be taken into consideration.

Students should identify a topic of interest in consultation with Faculty/Advisor. Review the literature and gather information pertaining to the chosen topic. State the objectives and develop a methodology to achieve the objectives. Carryout the design/fabrication or



develop codes/programs to achieve the objectives. Demonstrate the novelty of the project through the results and outputs. The progress of the mini project is evaluated based on a minimum of two reviews.

The review committee may be constituted by the Head of the Department. A project report is required at the end of the semester. The product has to be demonstrated for its full design specifications. Innovative design concepts, reliability considerations, aesthetics/ergonomic aspects taken care of in the project shall be given due weight.

vi) ASSESSMENT PATTERN

Mark distribution

Total Marks	Continuous Internal Evaluation Marks	End Semester Evaluation Marks	End Semester Examination Duration
150	75	75	1 Hours

Evaluation

The internal evaluation will be made based on the product, the report and a viva- voce examination, conducted by a 3-member committee appointed by Head of the Department comprising HoD or a senior faculty member, Academic coordinator for that program, project guide/coordinator.

The Committee will be evaluating the level of completion and demonstration of functionality/specifications, presentation, oral examination, work knowledge and involvement.

Split-up of CIE

Component	Marks
Attendance	10
Marks awarded based on guide's evaluation	15
Project Report	10
Evaluation by Committee	40

Split-up of ESE

Component	Marks
Level of completion	10
Demonstration of functionality	25
Project Report	10
Viva-voce	20
Presentation	10

